

The Wireless World

THE
PRACTICAL RADIO
JOURNAL
24th Year of Publication

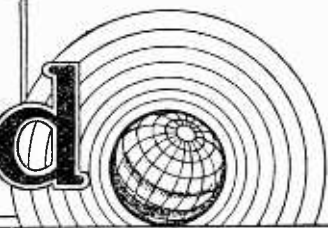
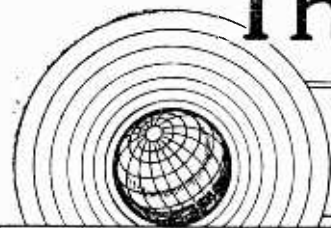

No. 786.

FRIDAY, SEPTEMBER 21ST, 1934.

VOL. XXXV. No. 12.

Proprietors: ILIFFE & SONS LTD.

Editor:
HUGH S. POCOCK.

Editorial,
Advertising and Publishing Offices:
DORSET HOUSE, STAMFORD STREET,
LONDON, S.E.1.

Telephone: Hop 3333 (50 lines).
Telegrams: "Ethaworld, Watloo, London."

COVENTRY: Hertford Street.

Telegrams: "Autocar, Coventry" Telephone: 5210 Coventry.

BIRMINGHAM:

Guildhall Buildings, Navigation Street, 2.
Telegrams: "Autopress, Birmingham." Telephone: 2971 Midland (4 lines).

MANCHESTER: 260, Deansgate, 3.

Telegrams: "Iliffe, Manchester." Telephone: Blackfriars 4412 (4 lines).

GLASGOW: 26B, Renfield Street, C.2.

Telegrams: "Iliffe, Glasgow." Telephone: Central 4857.

PUBLISHED WEEKLY. ENTERED AS SECOND
CLASS MATTER AT NEW YORK, N.Y.

Subscription Rates:

Home, £1 1s. 8d.; Canada, £1 1s. 8d.; other
countries, £1 3s. 10d. per annum.

*As many of the circuits and apparatus described in these
pages are covered by patents, readers are advised, before
making use of them, to satisfy themselves that they would
not be infringing patents.*

CONTENTS

	Page
Editorial Comment	241
From Triode to Double-Diode Pentode	242
Push-Pull Input Circuits	245
Paris Radio Exhibition	248
Practical Hints and Tips	251
News of the Week	252
FOREIGN PROGRAMME	
SUPPLEMENT, pp. 1—XXIV	
Broadcast Brevities	253
Letters to the Editor	254
Wireless on Gliders	255
Philips Superinductance Re- ceiver	256
New Apparatus Reviewed	258

EDITORIAL COMMENT

Shorts and the Ultra- Shorts

Problems of Allocation

IN terms of the age of wireless, short waves, and especially those below 10 metres, are of recent discovery, or at least, their practical value has only lately been realised. It is, therefore, quite natural that the gradual allocation of these wavelengths should have been made in a somewhat haphazard fashion. Very little systematic consideration seems to have been given to their distribution and their peculiar properties have not been taken into account sufficiently in this connection.

In other parts of the wireless spectrum it has been the custom to allot bands of frequencies to particular uses by international agreement. When it comes to allocating waves of an optical or quasi-optical character for such purposes as television, beacons, and short-distance communication, we believe that the problem should be tackled from a different viewpoint, with far more consideration given to the geographical positions in which the stations are intended to operate.

Local in Character

On long waves, for example, care is taken to see that overlapping channels are not allotted anywhere in the world because interference would take place, but it would be absurd to adopt the same principle in the case of optical waves used in this country and, for example, in Australia and America. Coming nearer home we might well suggest the possibility that a short-wave television service for the London area could utilise the same channel as similar services, say, in Wales and Scotland, without fear of mutual interference.

The problem, therefore, seems to resolve itself more into one of location than actual channels, and suggests the probability that if this principle is adopted more stations can be accommodated than could possibly be contemplated on the system of allocation applying to other wavelengths. Against this view, of course, must be mentioned the fact that, on the very short wavelengths maintaining a steady carrier frequency is not by any means easy and, therefore, a wider frequency channel will, in practice, be required than is necessary theoretically.

In taking wavelengths below 10 metres as a class, it must be remembered that this band includes waves of very different character, and it is probably necessary to consider sub-dividing them into several further classes.

Larger Wireless Sets

Portability the Only Excuse for Compactness

WE noticed in a paragraph in a daily newspaper recently a statement to the effect that the large type of wireless receiver is dead and that small receivers are to be the new order of the day.

Such a statement seems to us a curious contradiction of the facts. Midget sets have met with comparatively little popularity in this country, and we seem rather to be entering upon a vogue of better quality receivers when compactness is regarded as of little importance compared with other considerations.

There can surely be no sound argument in favour of extreme compactness where both quality and accessibility must suffer, except in the special case of receivers designed primarily for portability, when the owner expects a certain amount of compromise.

From TRIODE to DOUBLE-DIODE-PENTODE

The Purpose of Every Electrode

Part I.

The Triode and the Simple Tetrode

By A. L. M. SOWERBY, M.Sc.

PROGRESS in valve design has been so rapid during the last year or two that there is some excuse for those who have failed to keep au fait with developments in this all-important branch of radio technique. This series of clearly written articles presents a golden opportunity to make good the omission.

THE simplest thermionic valve that can be used to provide amplification of alternating voltages is the triode. As its name implies, the triode contains three electrodes. Of these, one, the cathode, acts as a source of free electrons, which boil off from it into the surrounding vacuum when its specially prepared surface is heated to the requisite temperature.

These electrons, being negative charges, are violently attracted towards the anode, an electrode maintained by a battery, or its equivalent, at a potential considerably more positive than that of the cathode. The third electrode, or grid, is an open-work metallic structure placed between cathode and anode in such a way that all electrons reaching the anode have to pass through the meshes of the grid.

In many valves the cathode is directly heated by the passage through it of a current. In this case it consists of a thin wire, the filament, coated with a material which liberates electrons freely at a dull red heat. The filament is usually designed to run from a 2-volt accumulator, though 4-volt and 6-volt valves are used for special purposes. In other valves the cathode is indirectly heated, in which case it consists of a coated tube within which there runs an insulated metal wire called, in this case, the heater. This separation of heating and electron-emitting functions provides freedom from hum when it is desired to heat the valve from the mains, and also allows the individual cathodes to be given any desired potential even though all the valves in the receiver are heated from a common source.

Controlling the Electron Stream

The electrons emitted from the cathode tend to form a cloud round it and have not, of themselves, any inclination to a concerted movement in one direction. The attractive field set up by the positive anode draws a proportion of them through the meshes of the grid, and on, in faster and faster flight, to the anode. But since they have to pass through the grid on their way, the number taking this trip through space can be controlled by applying a suitable potential to the grid. If

this is made negative enough, it will drive back so many electrons that scarcely any will reach the anode, and the anode current will be very small. If, on the other hand, it is given the same potential as the cathode, it will offer comparatively little hindrance to their flow, and the anode current will be large.

The way in which the anode current depends on the grid voltage is shown in the curves of Fig. 1, which are the familiar "characteristic curves" of an ordinary triode. The curves are made by setting the anode voltage at the figure marked against each individual curve, and noting

voltage AB such as that due to a signal will affect the anode current, set initially at P by choice of grid and anode voltages. The swing of grid voltage from A to B will clearly cause a corresponding swing of anode current from X to Y, so that the final anode current will consist of the steady current P with an alternating current of total swing XY superposed upon it.

Another set of curves can be plotted from the same data, showing the relationship between anode voltage and anode current at a series of fixed grid voltages. These curves, shown in Fig. 2, illustrate by their inclination the impedance, or A.C. resistance, of the valve. If the valve is set at $E_a = 143\text{v}$, $E_g = -2\text{v}$ (P in Fig. 2), an alternating anode voltage of 10 volts peak will swing the anode current in sympathy from E to F, a peak swing (PE or PF) of 0.73 mA. If the application of an alternating voltage V causes a current I to flow, the resistance in the circuit must be $E/I = 13,700$ ohms. This is, therefore, the resistance to the passage of alternating current offered by the valve when working at the grid and anode voltages symbolised at P. A little consideration will show that a steep curve implies that the valve has a low, and a flat curve a high A.C. resistance.

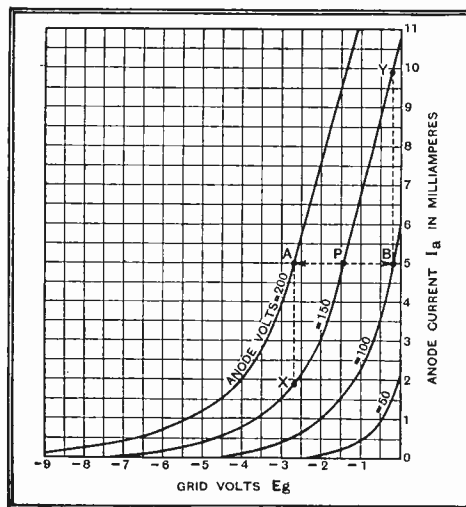

Fig. 1.—TRIODE. Grid volts-anode current. Characteristic curves of Cossor 41 MHL.

the anode current corresponding to each one of a number of grid voltages.

The straight portions of all the curves are roughly parallel; their inclination may be read as representing the number of milliamperes increase in anode current for a reduction in (negative) grid potential of one volt. This figure, conventionally taken at 100 volts on the anode and zero grid voltage, is known as the mutual conductance or slope of the valve. Since it shows the extent to which the potential of the grid controls the current through the valve, it is the main index to the valve's performance. In particular, it is valuable to know how an alternating grid

A Practical Example

In any practical stage of amplification it is not enough that the alternating voltage applied to the grid of the valve should develop an alternating current in the anode circuit; there must be some load in the anode circuit across which this alternating current can develop a voltage to feed the next valve's grid. The presence of this load modifies the shape, and especially the slope, of the curves of Fig. 1, so that the simple deduction of alternating anode current by means of the valve-curves of that diagram would lead to erroneous results in a practical case.

In the case of a stage of amplification such as that of Fig. 3, a simple construction from the curves of Fig. 2 will give all necessary information as to the degree of amplification obtainable. With an anode resistance of 20,000 ohms connected between battery and anode, the anode cur-

From Triode to Double-Diode-Pentode—

rent is zero if the voltage actually on the anode is 200v. (Point A, Fig. 2). At 10 mA. the whole voltage of the battery

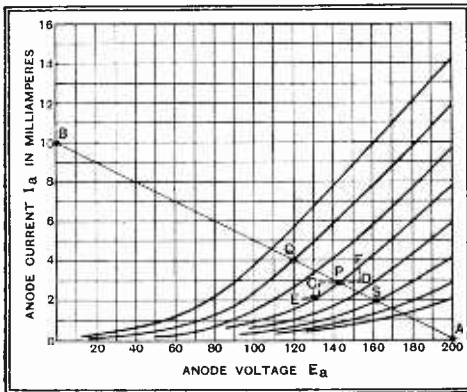

Fig. 2.—TRIODE. Anode current-anode volts. Characteristic curves of Cossor 41 MHL.

is dropped across the resistance, and the anode voltage is zero (Point B, Fig. 2). The line AB is thus the load-line, to some point on which every possible voltage-current combination taken up by the valve when operating must correspond.

If the initial bias on the valve is 2v., the working point will be at P. If the pick-up delivers a signal that swings the grid from -1 to -3v., the anode current and anode voltage will swing up and down the line AB between the limits Q and S. The alternating anode current will thus be 1.05 mA., and the alternating anode voltage 21.8v. The effective slope of the valve under these particular operating conditions thus amounts to 1.05 mA. per volt, and the effective amplification of the stage is 21.8 times.

The Amplification Factor

Inspection of the figure shows that if the line AB were more nearly horizontal the amplification would be greater (bigger swing in anode volts for 1 volt swing on the grid). A load-line passing horizontally through P would represent an indefinitely high A.C. load of low D.C. resistance (e.g., a high-inductance choke) and would give an amplification of 36.7 times. This figure, representing the maximum amplification obtainable from the valve under even theoretically ideal conditions, is called its amplification factor, represented by the symbol μ . It is, in effect, the change in anode volts necessary to hold the anode current constant against a change of one volt in the grid bias, and so may be obtained from ordinary "static" curves such as those of Fig. 1.

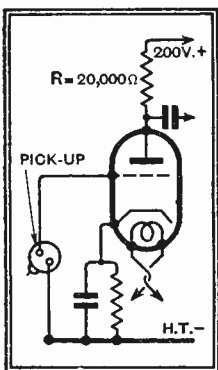

Fig. 3.—A triode amplifier for gramophone pick-up. Performance of this stage is analysed in Fig. 2.

If we know the amplification factor and the A.C. resistance of a valve, we can easily deduce the mutual conductance. A volt of A.C. applied to the grid is equivalent to μ volts at the anode, and the alternating anode current is driven through the A.C. resistance R_o by this voltage. Thus one volt at the grid drives a current of μ/R_o amps. through the valve; this ratio is therefore the mutual conductance g .

In such a case as that of Fig. 3, the alternating anode current has to be driven through both the A.C. resistance of the valve and the load-resistance; the current is therefore $\mu/(R+R_o)$ for every volt applied to the grid. This current, in flowing through the load-resistance R, develops across it a voltage, $\mu R/(R+R_o)$ for each volt on the grid; this expression, therefore, is that for the actual amplification realised in the particular stage shown. Inserting in the formula the individual figures for this case, where $\mu=36.7$, $R_o=13,700$, and $R=20,000$ ohms, we get 21.8 times, exactly as found graphically from Fig. 2.

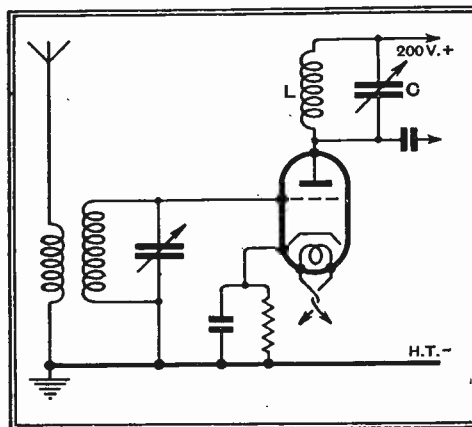

Fig. 4.—A triode amplifier for high-frequency signals. Exactly equivalent (L.C. replacing R) to Fig. 2.

For high amplification the requirements are evidently a valve of high amplification factor and low A.C. resistance, used in conjunction with a high anode load. In high-frequency amplification it is easy to build up a load of some 100,000 ohms in the form of a tuned circuit, while higher loads can be obtained by special design. In Fig. 4 is shown a stage of high-frequency amplification put together on the lines of the low-frequency stage of Fig. 3; the source of signals is now a tuned circuit connected to an aerial, while the anode resistance is replaced by the tuned circuit L.C., which may be reckoned as offering a load of some 100,000 ohms to signals of the frequency to which it is tuned.

This amplifier, simple and straightforward though it is, will not work. The reason is found in the capacity between anode and grid of the valve, through which energy is fed back from anode to grid in amount sufficient to set up and maintain oscillations in the grid circuit.

To prevent this unfortunate effect, it is customary to use a valve in which the capacity between anode and grid is reduced, by suitable screening, to a negligibly small amount. The screen used

consists of a closely woven mesh of wire interposed between grid and anode in such a way that no part of the anode can "see" any part of the grid. To prevent capacity between connecting wires, either the anode (most English valves) or the grid (American valves) is connected to a terminal on the top of the bulb, as shown in Fig. 5.

In order that the screen shall be effective, it is necessary that it shall be earthed sufficiently to prevent alternating voltages due to the signal from appearing on it when a signal is applied to the grid. If it is earthed directly its potential will be approximately that of the cathode, and by screening off the D.C. field from the anode it will prevent this from acting on electrons in the neighbourhood of the cathode; there will therefore be no anode current, and the valve will not amplify.

Effect of the Screen

By earthing the screen through a condenser large enough to act as a virtual short-circuit to signal voltages, it becomes possible to raise the screen to a suitable positive potential. If this is done, leaving the anode at zero potential, the cathode, grid, and screen form a triode of conventional type, the current through which is controlled by the grid-potential exactly as shown in Fig. 1.

Owing to the presence of the screen, a voltage applied to the anode will have a very small effect indeed upon the total number of electrons passing through the valve as a whole; this will depend almost entirely upon the voltage applied to the screen. Leaving this constant, the application of a steadily rising anode voltage will result in pulling more and more of the

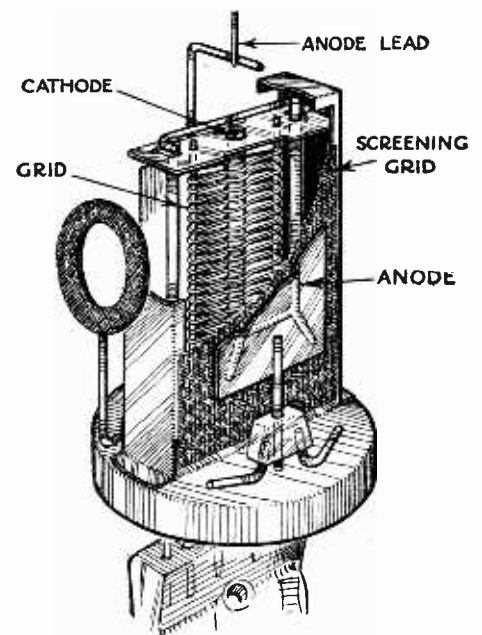

Fig. 5.—The arrangement of the electrodes in a typical screened grid valve.

electrons through the meshes of the screen instead of allowing them to finish their travels there. The anode, therefore, robs the screen.

This effect is shown in the curves of

From Triode to Double-Diode-Pentode—

Fig. 6. So long as the anode is decidedly more positive than the screen it takes nearly the whole of the current; the curve for $E_g = -2$ shows that over the range $E_a = 120$ to $E_a = 200$ the anode current only changes by 0.025 milliamp. Over this range of anode voltages the valve has a very high A.C. resistance; for this particular grid-bias voltage the figure is 3.2 megohms. The curve for $E_g = -1.5$ is less flat; its inclination gives an A.C. resistance of 0.50 megohm. Discussion of

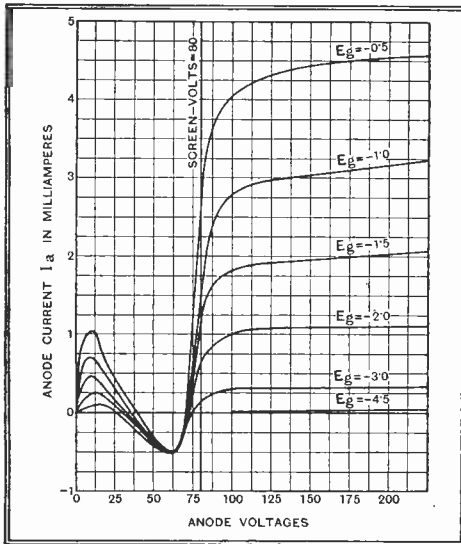

Fig. 6.—SCREENED TETRODE. Characteristic curves of Cossor MSG/HA.

the reason for the extraordinary antics of these curves in the region of anode voltages near and below the screen voltage will be postponed; it is enough to note here that the screen-grid valve is always used with an anode voltage considerably higher than that on the screen, so that only the flat part of the curves to the right of the diagram applies to ordinary usage.

Amplification Factor of S.G. Valves

At $E_a = 200$, the anode current of the valve of Fig. 6 is 2.05 mA. for $E_g = -1.5$, but falls to 1.1 mA. for $E_g = -2$. The average mutual conductance of the valve over this range of grid voltages is thus 0.95 mA. per half-volt, or 1.9 mA. per volt. Combining this figure with a mean value for the A.C. resistance—say 1.0 megohm—we find that the amplification factor of the valve is 1900 ($\mu = gR_o$). Some mild confirmation of this is obtained from Fig. 6 when we note that the curve $E_g = -2$ would apparently have to be continued the better part of a thousand volts to the right to increase the anode current to the value obtained by reducing the grid bias to -1.5 volts.

With a combination of high A.C. resistance and high amplification factor, the behaviour of a screened valve in a receiver differs in some respects from that of a triode. Reverting, for example, to the stage of high-frequency amplification of Fig. 4, we find that the gain of the stage, assuming the dynamic resistance R of the

tuned circuit to be 0.1 megohm, will be $1900 \times 0.1 / 0.1 \times 1.0$ if $R_o = 1.0$ megohm and $\mu = 1900$. This gain comes out at 173 times. Inspection of the figures just given shows that it is the high A.C. resistance of the valve that is responsible for the stage-gain being only one-eleventh of the rated amplification factor of the valve.

It is interesting to observe the way in which the gain increases with anode-circuit resistance for two equivalent valves, one a tetrode and one a triode. Curves showing this are given in Fig. 7; to make the comparison fair, both the valves taken to illustrate the point have the same slope of 2 milliamps per volt.

For low values of anode resistance, the gain given by the two valves is much about the same, but the curve for the triode bends over, and for high resistances becomes very nearly a horizontal line at a height equal to the amplification factor of the valve. The curve for the screened valve, on the other hand, is nearly a straight line of constant slope; it, too, will turn over eventually, but at values of anode-circuit load far above anything practically possible. Roughly speaking, the triode tends to give a constant gain, while the tetrode gives a gain proportional to anode-circuit load. Expressed differently, the triode gives an output at more or less constant voltage, irrespective of small changes in the value of a fairly high load, whereas the tetrode passes a constant A.C. current through any load that is not too extravagantly high.

Looking at the formula for gain, $A = \mu R / (R + R_o)$, it is clear that if the anode load is low compared with the A.C. resistance of the valve, we may write, for ap-

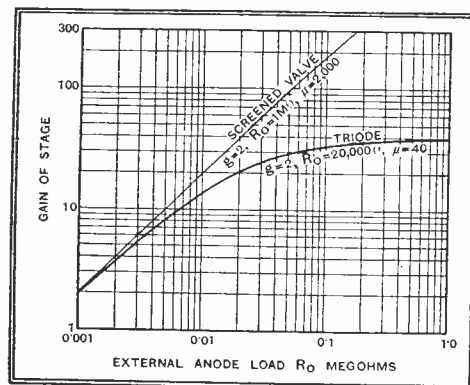
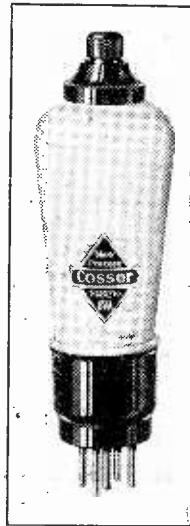

Fig. 7. Comparison of stage-gain given by triode and tetrode, both of slope 2 mA./v., with different anode-circuit loads.

proximate results, $A = \mu R / R_o$, or $A = gR$. Thus a tetrode of slope 2.0 mA./v., used with an anode resistance of 50,000 ohms, gives a gain of 100 times. (Accurate value, for the valve taken for Fig. 7, 95.3 times.)



The Cossor MSG/HA valve referred to in Fig. 6.

In the case of screened valves, their amplifying abilities can therefore be accurately compared by a simple comparison of slopes.

(To be continued.)

THE RADIO INDUSTRY

INTERESTING NEWS comes from Ferranti, who announce the introduction of a car-radio receiver, to be known as the Ferranti Motorset. It is of the single-unit type (with built-in speaker) and is directly controlled, being designed for mounting below the dashboard. Five valves, of which two are multiple valves, are used in a superheterodyne circuit; H.T. is derived from the car battery through a self-rectifying vibratory generator.

"The Cossor Wireless Book," just issued by A. C. Cossor, Ltd., Highbury Grove, London, N.5, is much more than a mere catalogue of valves. It includes many pages of general technical data, lists of stations, etc. Free copies are available for readers.

Twelve motor-generator sets, including one of unique design for operating at 50,000 volts above earth potential, have been supplied by the G.E.C. for the new Droitwich station.

Belling and Lee, Ltd., Cambridge Arterial Road, Enfield, Middlesex, have just issued a comprehensive booklet entitled "Cutting the Crackle Out of Radio." All aspects of man-made interference are dealt with in an authoritative manner, and much useful information on suppressive measures is given. Price: 6d., post free. Incidentally, the same firm have just issued their new season's catalogue.

Arrangements have now been completed for increased production of the Amplion "Radiolux" superheterodynes, with the result that reductions in price have become possible. New prices are:—A.C. table model, 12 guineas; D.C. table model, 13 guineas; radio-gramophone, 21 guineas.

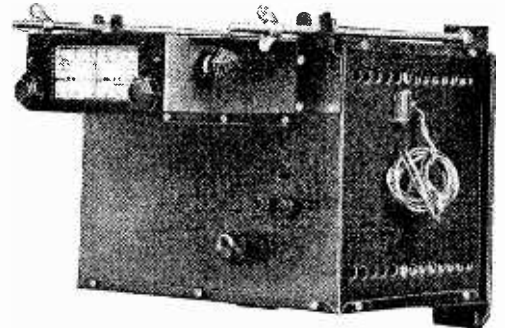

The new Ferranti "Motorset," for installation under the dash of a car. The tuning panel protrudes to the level of the dash-board.

The latest Marconi valve catalogue is a very helpful little booklet, and contains curves and operating data for all types of Marconi valves, with complete tables of valve combinations for a number of typical modern sets.

A booklet is being issued by Celestion, Ltd., which outlines the history of their loud speakers. A large quantity of these interesting booklets were distributed to visitors to Olympia, and copies can still be obtained.

Catalogues Received

Wingrove and Rogers, Ltd., Arundel Chambers, 188-9, Strand, London, W.C.2.—Polar condensers.

Rich and Bundy, Ltd., New Road, Ponders End, Enfield, Middlesex.—Mains transformers, chokes, output transformers, etc.

Halford Radio, Ltd., 39, Sackville Street, Piccadilly, London, W.1.—Halford superheterodyne receivers.

Push-Pull Input Systems

Methods of Feeding a Push-Pull Amplifier

By W. T. COCKING

THAT apparatus designed primarily for high-quality reproduction is appreciated by the discriminating listener has been amply demonstrated by the reception of *The Wireless World* Push-Pull Quality Amplifier.¹ Correspondence has shown, however, that some doubt exists as to the best method of coupling it with an existing receiver. Some notes on this matter were given in the constructional articles, but were necessarily confined to a few cases.

The input connections of the amplifier are shown in Fig. 1, and about 5.07 volts R.M.S., or 7.17 volts peak, must be maintained across the input terminals for an output of 4 watts. This input must be so split that one-half of it (3.585 volts) appears between AE and one-half between BE. Moreover, the voltage across AE must be 180 degrees out of phase with that across BE.

The simplest input system is undoubtedly a push-pull transformer with its two outer secondary terminals connected to A and B and its centre-tap to E. In order to preserve the transformer characteristics, of course, C1 and C2 should be short-circuited, and R1 and R2 removed

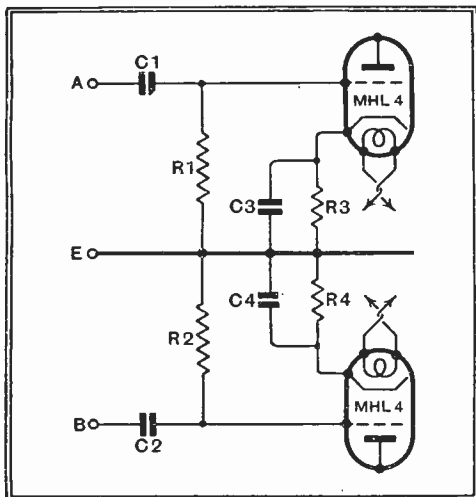
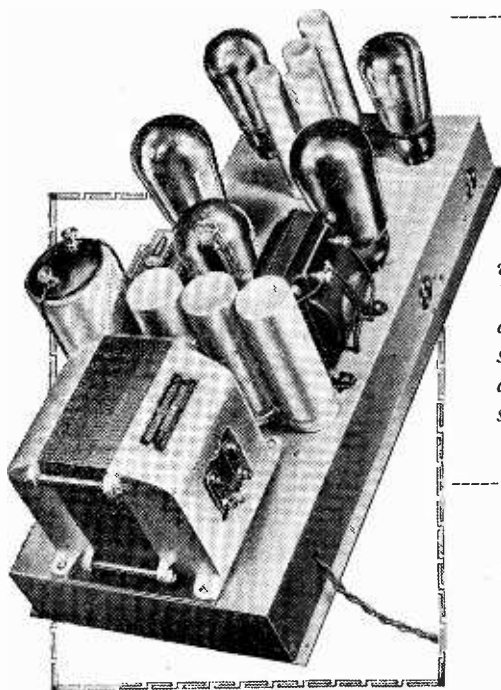

Fig. 1.—The input circuit of the Push-Pull Quality Amplifier.

from the amplifier. The primary of such a transformer is naturally connected in accordance with standard practice.

¹ *The Wireless World*, May 11th and 18th, 1934.



"The Wireless World" Push-Pull Quality Amplifier.

Many feel, however, that the full benefit of the amplifier is not obtained if a transformer be included, and prefer to adhere to resistance coupling throughout. The simplest coupling is then undoubtedly a direct feed from a diode detector, as shown in Fig. 2. The resistances Ra and Rb should each be of 50,000 ohms, and Ca can be 0.0001 mfd., the output terminals, of course, are connected to the correspondingly lettered input terminals of the amplifier.

Direct Diode Feed

The modulated input appearing across the circuit LC is applied between the diode anode and cathode in the usual way through the by-pass condenser Ca. Rectification occurs in the diode and modulation frequency currents flow through Ra and Rb exactly as with the usual diode detector. Since the current through Ra is the same as that through Rb, and the two resistances are of equal value, it follows that the potentials developed across them have the same value. Now consider the question of phase. Suppose that A is positive with respect to B at a given instant, then E is also positive with respect to B, and A is positive with respect to E. If E is more positive than B, however, B must be negative with respect to E. We thus find that the points A and B are always of equal and opposite potential with respect to E, and so the system is suitable for feeding a push-pull stage.

One of the greatest disadvantages of this system is that volume control must normally take place before the detector, and if gramophone reproduction be required, a separate feeder stage is necessary for this.

THE methods which can be employed for feeding a push-pull amplifier are many and various, and the correct arrangement depends upon the type of receiver which is used. Some of the more important feeder systems which may be used with "The Wireless World" Push-Pull Quality Amplifier are described in this article, and it is shown that the method to be adopted depends very largely upon whether a straight or superheterodyne receiver is employed.

It has been said that the total amplifier input required for 4 watts output is 7.17 volts peak, and if this is to be obtained with 80 per cent. modulation, the detector input must be about 13 volts peak if an MHL4 valve with grid and anode strapped be used for the diode. If the two diode anodes of a duo-diode-triode be used, the input required will be about 15 volts peak. In either case, detection should be almost completely distortionless. An input of this order can rarely be obtained, even from

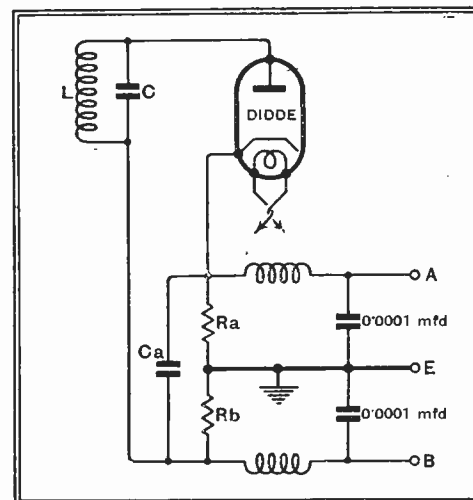

Fig. 2.—The amplifier may be fed directly from a diode in the manner shown in this diagram.

a local station, without an H.F. stage, and for more than purely local reception two stages should be provided.

One disadvantage of the circuit of Fig. 2 is that neither terminal of the tuned circuit can be earthed, but this may be overcome by rearranging the connections on the lines shown in Fig. 3. The tuned circuit can then be of any conventional type such as an H.F. transformer or the tuned grid circuit.

A more generally useful arrangement is shown in Fig. 4, and it will be observed that the triode section of the duo-diode-triode valve is connected in the same way

Push-Pull Input Systems—

as the triode in the feeder unit described for the Push-Pull Quality Amplifier. In this case the push-pull output is obtained with the aid of a triode, and the

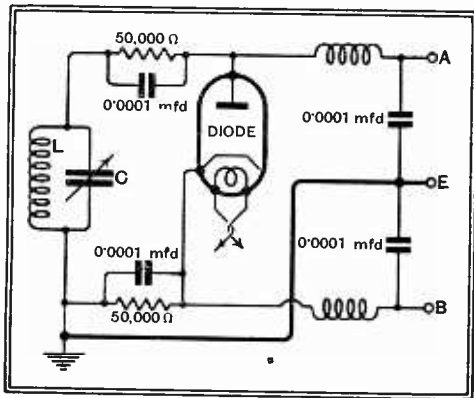

Fig. 3.—An alternative method of using a diode for feeding the amplifier when the tuned circuit must be earthed.

mechanism is the same on both radio and gramophone. The operation can best be seen from the simplified diagrams of Fig. 5, and the complete triode circuit is shown at (a). Now the impedance of Ca and Rd in parallel is negligible at the operating frequencies, and the reactance of Cb is also negligibly small, while Rc is very high. As regards L.F., therefore, we can replace Fig. 5a by Fig. 5b, and it will be seen that as in the diode circuit the output is taken across two series connected resistances of equal value, the mid-point of which is earthed. The operation, therefore, is identical, and the differences in the practical circuit are only those occasioned by the necessity for providing the correct steady operating potentials on the valve.

Using a Duo-diode-triode

In Fig. 4 rectification occurs in the diode circuit, and the resulting L.F. potentials are passed to the triode through

a resistance-capacity coupling. Since there is an additional stage of amplification, the detector input is now much less, for it has to provide an output of only 0.36 volt peak on an 80 per cent. modulated carrier. When giving such a small output a diode detector is by no means distortionless, so in the interests of quality it is necessary to provide the detector with a larger input and to throw away a portion of the output.

Recent work on diode detectors has shown that when the MHD4 valve is used with the two diode anodes connected together, and with a load resistance of 100,000 ohms, the input can be as small as 2 volts peak without distortion becoming

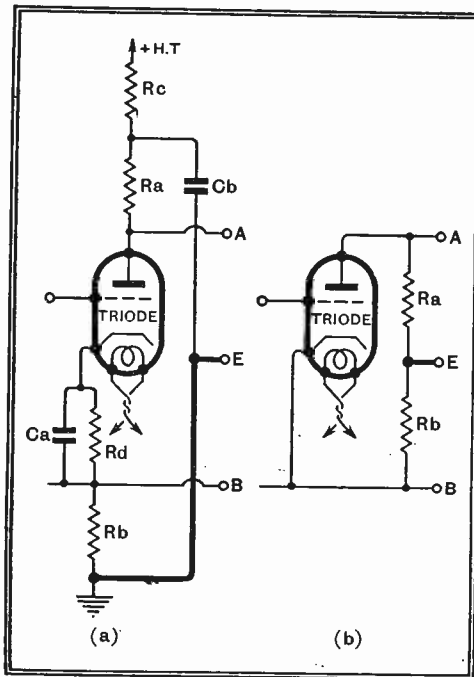

Fig. 5.—The fundamental connections of the triode portion of the valve in Fig. 4 are shown at (a), while (b) illustrates how the phase reversal is obtained.

appreciable. It is, in fact, only about 0.25 per cent. for 80 per cent. modulation, and is even less for larger inputs. It has previously been thought that the input should be of the order of 10 volts, but it now appears that this figure is unnecessarily high. It should not be forgotten, however, that diodes vary in their characteristics, and a valve of a different make may require a larger input.

With a 2 volts detector input, the output is 1 volt peak for 80 per cent. modulation, and the triode portion of the valve requires 0.36 volt. Since we must throw away a portion of the detector output by means of

some form of potentiometer, it is convenient to adopt a round figure for the ratio of detector output to amplifier input, for this will lead to standard values of components. Let this ratio be 3-1, obtained by the insertion of the 500,000 ohms resistance R' (dotted in Fig. 4). The detector output required is then $0.36 \times 3 = 1.08$ volts peak, and will be obtained with an 80 per cent. modulated carrier of 2.15 volts peak, or 1.52 volts R.M.S. between the points (aa) of Fig. 4.

The voltage at (aa) must be produced across some type of H.F. circuit, and it is here that most difficulty arises, for neither terminal may be earthed. In the case of a superheterodyne the matter is easily arranged, and the circuit of the preceding stage can take the form shown in Fig. 6. There is also no difficulty in a single-span receiver and details of the connections were given in *The Wireless World* for June 22nd, 1934.

With a straight set the solution is not so straightforward, because in these days of ganged tuning one side of the variable

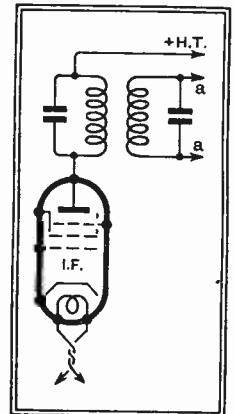

Fig. 6.—The last I.F. coupling in a superheterodyne usually takes the form shown here and it may precede the valve of Fig. 4 by joining the points (aa) on the two diagrams.

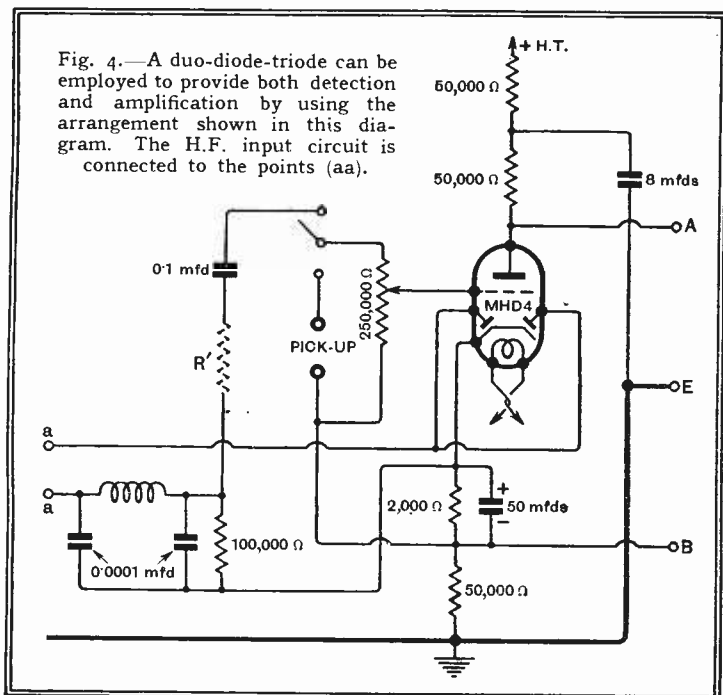

Fig. 4.—A duo-diode-triode can be employed to provide both detection and amplification by using the arrangement shown in this diagram. The H.F. input circuit is connected to the points (aa).

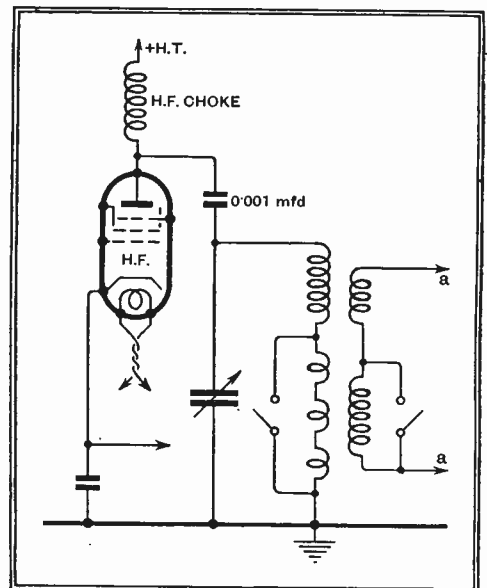

Fig. 7.—In the case of a straight set the feeder system of Fig. 4 is best preceded by a transformer coupling as shown in this diagram.

condenser must be earthed. The difficulty can be got over by adopting the arrangement of Fig. 7. It will be seen that an H.F. transformer is employed, but the normal primary winding is used to feed the diode detector, and the tuned circuit is fed from the H.F. valve by means of an H.F. choke and a condenser.

Push-Pull Input Systems—

For maximum efficiency, the transformer ratio should not be greater than some 2-1, but quite good results can be secured with a ratio as high as 3-1. With none of these systems, of course, is it possible to employ reaction satisfactorily.

Although the duo-diode-triode lends itself best to feeding a push-pull amplifier, it is quite possible to use a grid detector and reaction can then be embodied. The connections of such an arrangement are shown in Fig. 8 which is self-explanatory. Apart from the ability to obtain reaction, this system has no advantage over the recommended method embodying a duo-diode-triode, and it is indeed inferior to it in certain respects.

The use of the amplifier on gramophone is quite straightforward and has already been fully dealt with, but it is sometimes desired to employ a microphone. Essentially this is no different from a pick-up, and it is only necessary to connect the secondary of the microphone transformer to the pick-up terminals. Most good quality microphones are designed to operate into an impedance of 500 ohms, and the resistance of the volume control is 250,000 ohms. In general, therefore, the transformer should have a ratio of 1-22.4.

Using a Microphone

The only difficulty which may be experienced is in obtaining sufficient volume, for most good quality microphones give only a small output, perhaps 0.1 volt or

less, while the input required by the amplifier is about 0.36 volt peak. The only remedy, of course, is to increase the amplification, and there is no doubt that this is best done by including another stage of push-pull amplification between the feeder valve and the amplifier proper. A pair of MHL4 valves with the same connections and circuit values as those in the amplifier should function admirably. This arrangement is hardly worth while,

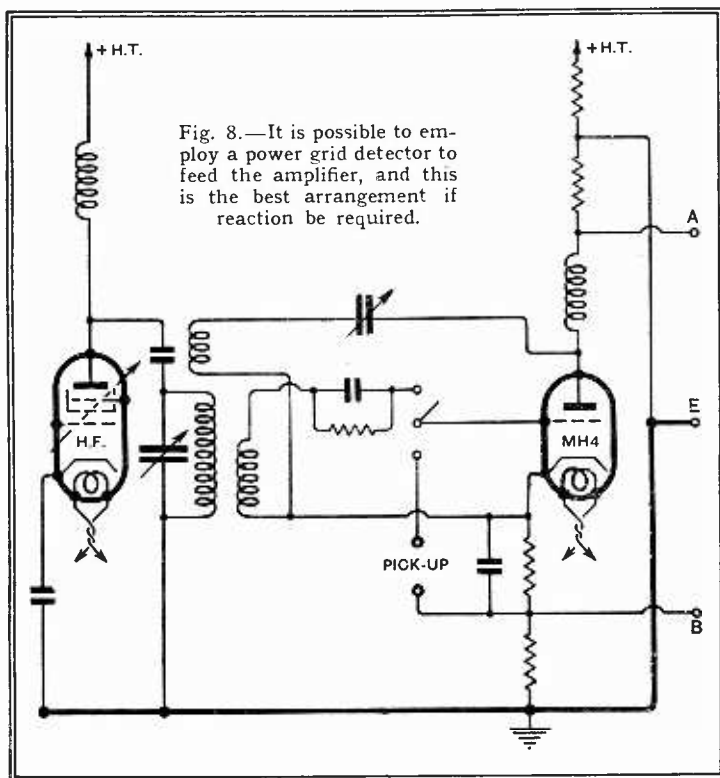

Fig. 8.—It is possible to employ a power grid detector to feed the amplifier, and this is the best arrangement if reaction be required.

of course, unless the equipment is to be used chiefly with a microphone, for on radio and gramophone the amplification would be unnecessarily large.

In general, therefore, the arrangement of Fig. 9 is best adopted for microphone working. The L.F. transformer should be of low ratio, about 1-1, so that excessive amplification is not obtained, and a good frequency response is secured with the pick-up volume control connected across its secondary. The necessary current for operating the microphone can be secured by connecting a battery to the points (bb), or it may be obtained by closing these points by a resistance, shunted by a 50 mfd. electrolytic condenser, which is included in the main negative H.T. return lead of the amplifier. The value of the resistance, of course, will depend upon the current and voltage requirements of the microphone, and so will vary according to the component selected.

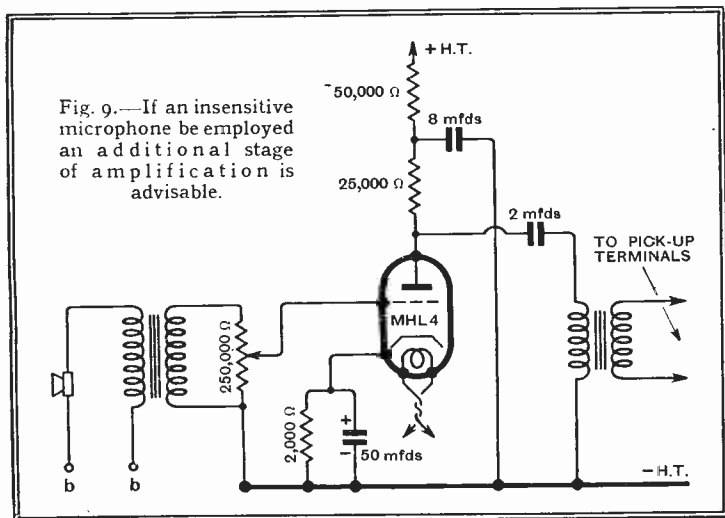

Fig. 9.—If an insensitive microphone be employed an additional stage of amplification is advisable.

U.R.S.I. London Meeting

THE Union Scientifique Internationale Radio (U.R.S.I.) met in London for its third plenary session between September 17th and 19th. In the absence through illness of the president (Prof. A. E. Kennelly, of Harvard), Dr. W. H. Eccles, F.R.S., acted as president for the London meeting. The delegates were welcomed on behalf of the president of the Royal Society on the afternoon of the 17th and were entertained to dinner by the Government on September 18th, when the Postmaster-General, Sir Kingsley Wood, was the chief speaker.

The delegation assembled in London included representatives from America, France, Belgium, Italy, Denmark, Sweden, Switzerland, Japan, New Zealand and South Africa, amongst the best-known visiting scientists being Dr. J. H. Dellinger, of the U.S. Bureau of Standards; Dr. van der Pol, of Eindhoven; MM. Gutton and Mesny, from France, and Dr. Harald Norinder, the well-known Swedish-American authority on lightning.

The work of the Union is divided between five Commissions: (1) Standards and Measurements; (2) Propagation of Waves; (3) Atmospherics; (4) International Co-operation, and (5) Radio Physics.

During the London meeting the delegates made numerous visits to adjacent places of radio and allied interest, these including the National Physical Laboratory, the Radio Research Station, Slough, the Rugby and Baldock stations of the Post Office, and the Cavendish Laboratory at Cambridge, while other activities included receptions at Broadcasting House and at the Royal Institution, where the director, Sir William Bragg, gave an account of the researches of Faraday.

Television for the Amateur Constructor, by H. J. Barton Chapple, M.Sc., 2nd edition, 266 pages, +xxiii. Published by Sir Isaac Pitman and Sons, Ltd. Price 12s. 6d.

The practical, as distinct from the theoretical side of television forms the keynote of this book, and the various theoretical considerations which necessarily arise are dealt with in a very elementary manner. The first chapter deals with the general principles of television and the second with the fitting up of a suitable workshop for the home construction of apparatus. The next five chapters are devoted to a discussion of suitable types of television receiver and H.T. supply units, and constructional details of a certain amount of apparatus is given. The theoretical treatment is sketchy, and it is unfortunate that in certain cases the apparatus recommended is not of a type which would usually be considered suitable for the best reproduction of sound broadcasting. One is tempted to enquire, therefore, how it can meet the more stringent requirements of television.

Four chapters are devoted to a description of the construction and operation of disc and mirror-drum apparatus, and in the final chapter the possibilities of high-definition television on ultra-short waves are briefly discussed. In the preface the author states that in preparing this second edition he has endeavoured to bring the book up to date, but we notice that the valves recommended for certain receivers described are still of the 6-volt types which have been obsolescent for some years. When revising the older edition a point like this might well have received attention.

Paris Radio Exhibition

Considerable Technical Progress in the French Industry

THE eleventh Radio Show, which was held at the Grand Palais, in Paris, from September 6th—16th, brought together more than 200 exhibitors and attracted a large public. For the first time foreign firms have been allowed to participate in the Exhibition. It may be said at once that, stimulated by foreign influence, the technical side of the French radio industry has made such progress in recent years that it is now well able to hold its own in competition with foreign products

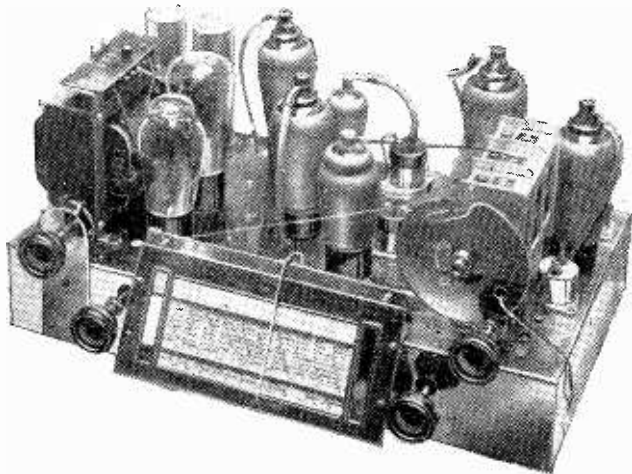

which makes a high degree of selectivity imperative.

Since 1926 the superheterodyne has maintained its position as the most popular circuit in France. It may be

cuit diagram of a good French superheterodyne (the "Superoctodyne 8"), by Mildé. This all-wave receiver includes a pentode H.F. stage, an octode frequency-changer, a pentode I.F. valve, followed by a diode for the detector and A.V.C. purposes.

(Left) A good example of the French superheterodyne "Superoctodyne," by Mildé. It should be noted that the tall screened coils are of the iron-cored type.



A Grammont receiver fitted with Telematic tuning system.

THE very drastic effect which the financial crisis in France has had upon wireless manufacturers has been beneficial in so far as it has contributed to raise the general standard of production. In spite of a constant tendency towards price reduction, apparatus of good quality is well in evidence.

Midget sets which in 1933 were to be found on almost all the stands, and which seemed as if they would bring the musical reproduction of radio into disrepute, have now almost disappeared. Refinements such as A.V.C., silent tuning, tone control, visual tuning indicators, which were only associated last year with receivers of very high prices, appear in 1934 even on the most popular models.

It is also important to record the appearance of a very large number of all-wave receivers covering wavelengths from 15-1,950 metres.

At least 90 per cent. of the receivers at the Show were superheterodynes, the number of valves utilised varying from four to eight, and the prices ranging from £10 to

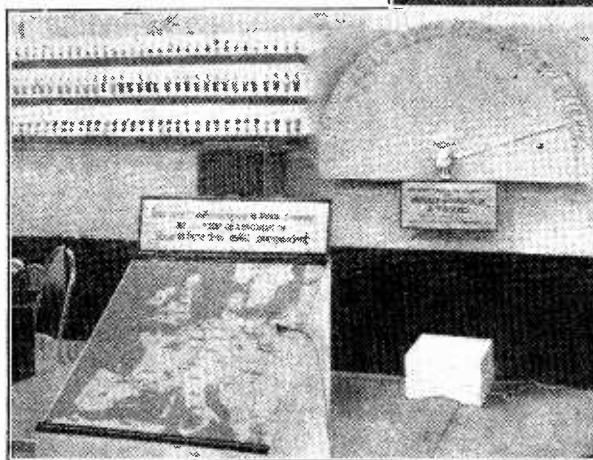

Apparatus set up at the Exhibition to demonstrate the Telematic remote control tuning system. The tuning condenser is rotated by means of a small electric motor to its proper tuning position, corresponding to the station on the map where the plug is inserted into the socket.

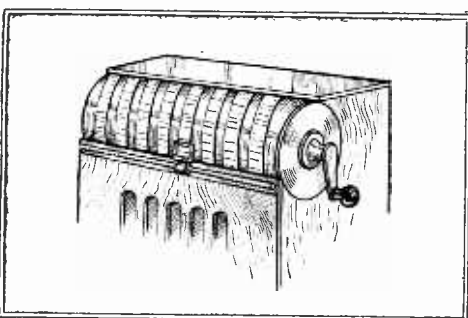

An original type of tuning scale. The names of the stations are helically arranged on a raised strip on the cylinder. When the cylinder is turned the names of the stations appear in the window, which can travel along a guide.

£40. The popularity of a frequency-changing circuit in France can be explained principally because of the chaotic state of the present broadcast distribution in France,

on account of this necessity for extreme selectivity that receivers of high quality have delayed making an appearance, and it is only recently that receivers capable of good reproduction, but employing the superheterodyne principle, have been developed as a result of modern circuit improvements.

For the last three years France has been invaded by valves of American type, which, in spite of the cost of transport and import duty, are sold cheaper than valves of European manufacture. On this account, the majority of French superheterodynes previously employed the American pentagrid as a frequency-changing valve. But the recent drop in prices of European valves, and particularly the production of the octode, have had a considerable effect on the demand for American types. At the Paris Show this year the majority of the superheterodynes were fitted with octodes.

By way of example, we publish the cir-

An additional valve is used for silent tuning, and the two L.F. stages both embody pentodes. The visual indicator consists of a milliammeter located in the plate circuit of the two first valves, while the coils are iron-cored types. The sensitivity of the receiver is given as 3 microvolts, the selectivity 10,000 to 1 for 9 kc., and the undistorted output 3.5 watts.

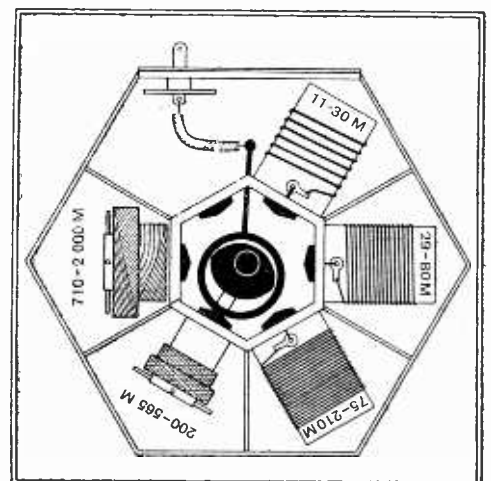

A sectional view of the all-wave coil unit by Gamma. The switching arrangement is particularly ingenious.

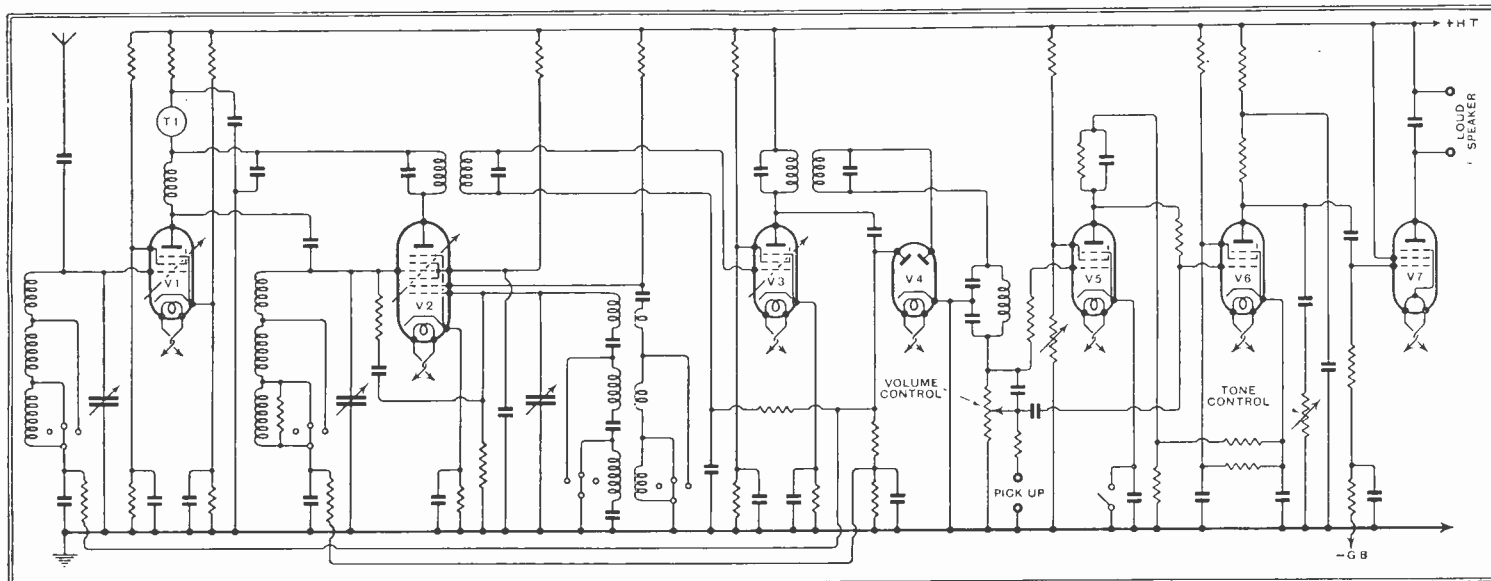

Circuit of the Mildé "Superoctodyne" all-wave receiver with A.V.C., silent tuning, and visual indicator. The valve V5 provides for silent tuning by biasing the valve V6 beyond the current cut-off point in the absence of a signal.

In the simpler types of superheterodynes all of these refinements are naturally not included, but, all the same, even the most modest of them, with only four valves, generally employ A.V.C., although not

A receiver for D.C. alone is not popular in France, and scarcely any manufacturers produce them. Every type of receiver is now fitted with moving-coil types of loud speaker.

escutcheon window then shows the name of the station to which the receiver is tuned. By this arrangement the length of the scale is extended to several metres.

Another manufacturer, Grammont, has adopted a tuning system invented by Vinogradow, and known as "Telematic." This is a method of automatic tuning by remote control in which the variable condenser is rotated by a small electric motor. To set the motor in action a plug has to be inserted in a socket; the inventor has been able to arrange the sockets to correspond to the different stations on a map. This device is illustrated on the previous page.

It would seem as if a great effort has been made on the part of manufacturers to improve the external appearance of their receivers. This is probably because in France "*c'est Madame qui choisit le récepteur et c'est*

Amongst the components the new coil units for all wavelengths produced by Gamma are of particular interest. These units are offered in hexagonal form, divided into fifteen shielded compartments. Each unit consists of aerial coil, H.F. coupling, and oscillator coil, and they cover five wavelength ranges: 11-30 metres, 29-80 metres, 75-210 metres, 200-565 metres, and 710-2,000 metres, making in all thirty coils. Oscillator coils are provided with trimmers and padding condensers.

All this arrangement is accommodated in a hexagonal unit 145 mm. long and 80 mm. in diameter, and the switching is incorporated in the centre of the unit. The switch itself is of ingenious construction; it is composed of a series of fourteen rings controlled by an eccentric. Each unit can make con-

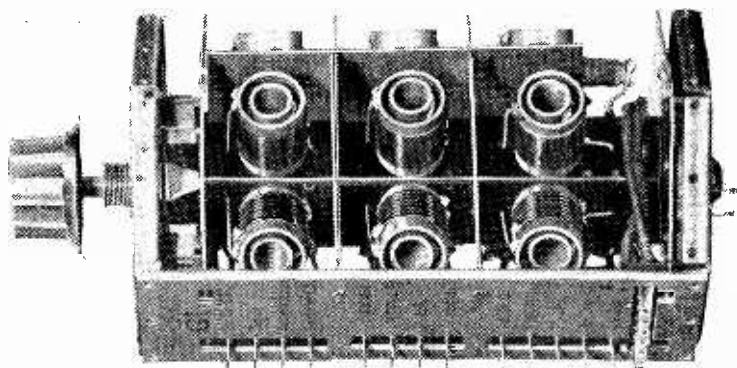

External aspect of the Gamma unit without external screen, and on the right is shown the axis of the switch with its 14 rings.

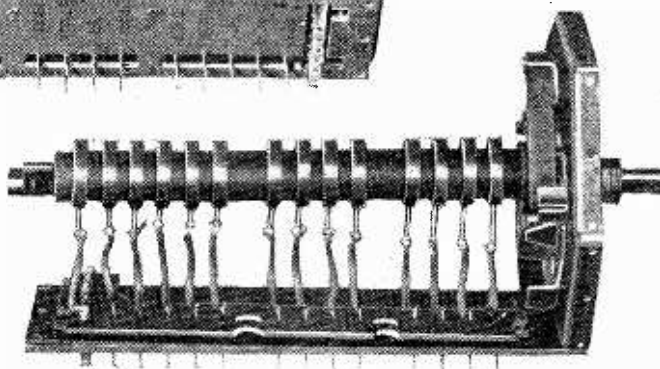

always in a very efficient form.

This year for the first time for three or four years, battery sets have made a modest come-back. Two models were shown, one of which is designed by a battery manufacturer, and the other by the firm Geco.

The great majority of French receivers, however, are for alternating current, but



The group of coils covering wavelengths 11-30 metres.

there are signs that the universal A.C.-D.C. sets are becoming more and more popular. All valve manufacturers in France now have A.C.-D.C. valves for series connection at 12-30 volts. Quite a number of D.C. receivers now have their equivalent in universal A.C.-D.C. types,

Monsieur qui paie...

The cabinets are often very artistic productions constructed of the best woods, but the greatest ingenuity has probably been shown in the direction of the presentation of tuning scales. In this connection, one manufacturer has had the idea of placing the names of the stations on a helix, the strip carrying the names being in relief on a cylinder placed at the top of the receiver. Rotation of the cylinder controls the variable condensers, and at the same time carries along a small escutcheon sliding on a guide along the length of the cylinder. A sketch of the device is shown on the previous page. The

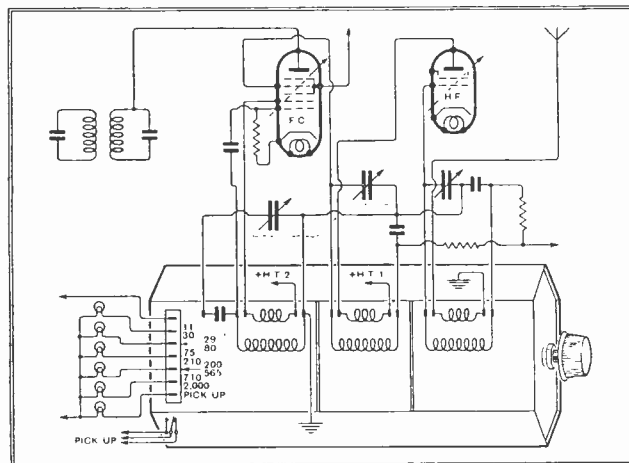

Circuit of the tuner showing the connections to the H.F. and oscillator modulator valves.

Paris Radio Exhibition—

tact with six radially disposed points. The ring does not turn, but oscillates in a plane perpendicular to the axis, and a stiff wire is soldered to the unit, which permits movement of the ring without allowing it to rotate. The switch provides in six positions for no fewer than eighty-four contacts, the

sixth position providing for the inclusion of a pick-up.

In concluding with a description of this ingenious accessory, it remains only to draw attention to the fact that the French Exhibition gives evidence of a very real effort towards improvement in quality.

E. AISBERG, Editor "Toute la Radio."

The Diary of an Ordinary Listener

The Problem of Station Identification

CONTINENTAL stations might, with advantage, follow the good example set by the B.B.C. in the matter of punctuality and station-identification. It is a rare occurrence for the B.B.C. to be behind the advertised time with their programmes, and almost every announcement is prefaced with the name of the station transmitting, whereas many Continental stations seem to regard time as a mere matter of relativity, and feel satisfied if any part of their programme begins within twenty minutes of its advertised time. One has often to wait impatiently until the end of a long concert before being absolutely certain of the station, especially if it is in the somewhat congested area between the London and the Scottish Regional wavelengths inhabited by Strasbourg, Budapest, Berlin Funkstunde, Moscow IV, and Milan, together with several lesser lights. It is, of course, true that the B.B.C. does not announce the station nor the next item during the "Proms.," but this is an exception to the general rule, and I have no doubt that foreign listeners would welcome an announcement of the next item in place of a transmission of the applause following the previous item. These sage reflections are the outcome of a long wait on Thursday, September 6th, for a Beethoven quartet which was down on the programme of Poste Parisien. It seemed as if the relay of Cigány music from Budapest was never coming to an end, and, although I quite enjoyed the light music, it was not the Beethoven I wanted. Eventually, I got tired of waiting, and switched over to Frankfurt for part of the concert from Nurnberg, where the Nazi Festival was in full swing, and thence to Rome for the end of "The Merry Widow."

"Chu-Chin-Chow"

The following evening an influx of visitors prevented me listening to anything much beyond social chatter.

On Sunday Luxembourg attracted my attention with a good selection from "Chu-Chin-Chow," after which I went over to Radio-Paris to hear some popular Italian airs sung by Robert Marino to a mandoline accompaniment. But the mandoline is an instrument of which I soon tire, so, after hearing a song by Tosti and part of another by Lama, I transferred my attention to Poste Parisien, where a concert of light music was being given by the orchestra conducted by G. Balay. From France I went over to Denmark for the concert of their National music by the Radio Orchestra, broadcast from Kalundborg and Copenhagen, and thence to Hilversum, where the excellent A.V.R.O. orchestra were in the midst of some music which I was unable to identify, though, as it had a decidedly Beethovenish flavour, I found it eminently suited to my taste; this was

followed by an Aria from Massenet's "Manon," which brought the concert to a close, so I went south to Munich, and heard the very efficient N.S. orchestra in a "Meditation" by Haydn.

Having left my receiver tuned to the Munich wavelength, this was naturally the first station I heard when I switched on the following evening, and I was fortunate to come in for Mozart's elaborate Aria, "Ach was webrach ich," charmingly sung. Brussels No. 1 was transmitting a Wagner concert relayed from the Casino at Vichy which started with the Overture to "The Mastersingers," but it sounded to me as if the brass had not sufficiently warmed up, and was, in consequence, decidedly sharp, so I went over to Hilversum, where the

A.V.R.O. orchestra and Hans Schouwman were giving a fine rendering of Grieg's Pianoforte Concerto in A Minor. Reception from Hilversum did not appear as good as usual, the station being somewhat heterodyned, probably by Brasov, so I returned to Brussels for the "Parsifal" overture, by which time the trumpets were in perfect tune, and performed their important part in a most satisfactory manner.

Munich again seemed to offer the greatest attraction during the earlier part of Tuesday evening, and I heard the end of the 1st Act of "La Bohème." Leaving Mimi to go off to the fair with her artist friend amid thunders of applause, I next tried Kalundborg, being anxious to hear the Westminster Choir of Princeton, U.S.A., and to compare it with our own choir in Westminster Abbey: Kalundborg was suffering from morse interference, so I changed over to Copenhagen, where the result was better but not altogether satisfactory. I heard the choir in a chorus by J. S. Bach and was struck with their precision, but could not hear them clearly enough to make a fair comparison with their English rivals.

I finished up the evening with a good selection of operatic music by the Stuttgart Station Orchestra, which included Nicolai's overture "The Merry Wives of Windsor," and the waltz from Johann Strauss's "Weiner Blut."

CALIBAN.

In Next Week's Issue

The Standard Two

An Economical Two-valve Battery Receiver

A SIMPLE receiver employing modern valves and components can give a surprisingly good performance when operated under suitable conditions. A Q.P.P. output stage enables good quality to be secured economically at a volume level sufficient for many requirements, while a reacting detector with a single-tuned aerial circuit provides adequate sensitivity and selectivity for local reception. In good locations it is even possible to secure good reproduction of several Continental transmissions.

THE LIST OF PARTS REQUIRED

- 1 Variable condenser, 0.0005 mfd. and "Mystic" drive
Graham Farish Formo. SU5
- 1 Reaction condenser, 0.0003 mfd. Ormond R.508
- 1 Knob for above Ormond R.355
- 1 Slow-motion midget condenser, 0.0001 mfd.
Ormond R.149
- 1 Q.P.P. transformer, 1-8 Graham Farish "Quip."
- 1 Valve holder, 5 pin
Clix chassis mounting standard type
- 1 Valve holder, 7-pin
Clix chassis mounting type
- 1 Fixed condenser, 0.0001 mfd. T.C.C. Type "M"
- 1 Fixed condenser, 0.0002 mfd. T.C.C. Type "M"
- 1 Fixed condenser, 0.0005 mfd. T.C.C. Type "M"
- 2 Fixed condensers, 0.005 mfd. T.C.C. Type "M"
- 1 Fixed condenser, 1 mfd., 400 volts, D.C. test. T.C.C.50
- 1 Resistance, 50,000 ohms, 1 watt
Graham Farish "Ohmite"
- 1 Resistance, 100,000 ohms, 1 watt
Graham Farish "Ohmite"
- 1 Resistance, 1 megohm, 1 watt
Graham Farish "Ohmite"

- 1 Resistance, 2 megohms, 1 watt
Graham Farish "Ohmite"
- 1 Screened H.F. Choke Kinva I.D.S.
- 1 S.P.D.T. Switch Bulgin S.81
- 2 Three-point switches Bulgin S.87
- 1 Six-way connector Bryce
- 1 Four-way battery cable, with terminals and spade ends Harbros
- 4 Ebonite shrouded terminals, A.E. Pick-up (2)
Belling-Lee, Type "B"
- 1 9-volt grid bias battery
- 1 Pair grid bias battery clips Bulgin No. 1

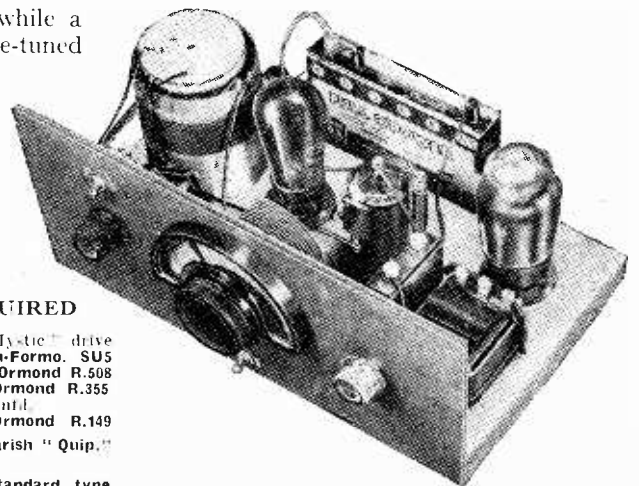

- 1 Three-pin plug and socket panel Belling-Lee 1119
- 1 Paxolin tube, 3in. diameter by 3 1/2in. length
Wright and Weaire
- 2 Coils (see text)
- Wood baseboard, 12in. by 7in., Wood panel, 12in. by 6in.,
1 oz. No. 22 tinned copper wire, 5 lengths 8/32stollex,
wool, etc.
- Screws: 2 1/2in. No. 2 R/hd., 1 1/2in. No. 4 R/hd., 4 3/4in.
No. 4 R/hd., 4 1/2in. No. 4 R/hd., 4 1/2in. No. 4 C/ck.
- Valves: 1 Osram H12; 1 Osram QP2
- Loud Speaker: Moving coil with special transformer
Goodman's "Grille" PM

HINTS and TIPS

AS most readers are aware, the National programme will shortly be radiated only by the long-wave transmitter at Droitwich, and no longer by local medium-wave stations. One of the minor results of this somewhat revolutionary change in broadcasting will be to render almost useless that particular type of two-station receiver which is designed for switching over between "National" and "Regional" programmes. Admittedly, sets of this type have never enjoyed wide popularity, but quite a large number of them are probably still in use, if only as understudies to more ambitious outfits.

Alternative Programme Switching

Although it is by no means impossible to modify a "switch-over" set to cover a

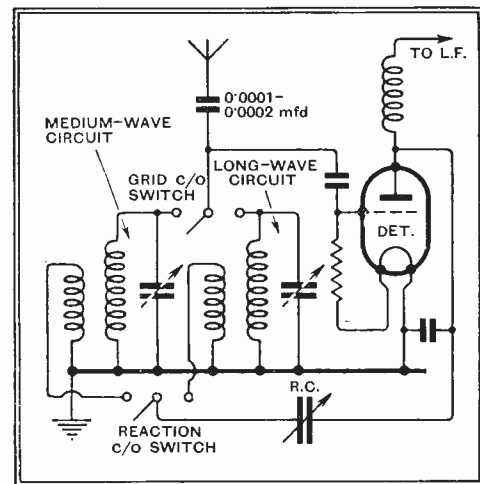

Fig. 1.—Switching pre-tuned circuits into action; a simple alternative programme set.

long-wave and a medium-wave station (instead of two different wavelengths on the medium band), an alteration or addition to the existing tuning coils is always involved. Now few of the coils used in this type of set are of current design, and so the obtaining of long-wave counterparts is almost impossible; as a result, it will probably be found easiest to re-model the tuning system entirely.

In the accompanying Fig. 1 is shown what represents one of the simplest and most straightforward switching systems for alternative-station reception. Admittedly, it has no pretensions to high performance, but is capable of working satisfactorily under fairly easy conditions, and it offers the great advantage of needing nothing abnormal in the way of coils. Semi-variable or cheap fully-variable condensers may be used for tuning.

It will be seen from the diagram that two single-pole double-throw switches are required, one for changing over the detector grid connections and the other for the reaction circuit. Although those switches are shown separately for the sake of clarifying the operation of the system, in actual practice the two elements would

Practical Aids to Better Reception

be combined in a single double-pole double-throw switch.

USERS of wave-traps designed to suppress second-channel interference, such as the twin-station device described in *The Wireless World* of January 26th, may be reminded that these pieces of apparatus should not be used in quite the same way as ordinary wave-traps.

Eliminating Second Channel Interference

Instead of adjusting the trap circuits to give minimum signal strength from the interfering local stations, they should be set to the wavelengths at which the interfering whistles occur, in order to reduce their intensity to the greatest possible extent.

WE all know that a periodical checking of the various anode currents provides a most helpful and informative index as to the condition of both receiver and valves. But, all too often, the task of making these measurements is postponed indefinitely, for the reason that suitable "break-in" points for inserting the meter in circuit are not accessible, and as a rule it becomes necessary to disturb the internal wiring.

Measurements Without Instability

Alternatives to this procedure are offered by the use of valve adaptors (for interposition between the various valves and their holders), or, so far as screen-grid valves are concerned, by connecting the meter between the anode cap and the existing anode connection; these points are generally accessible. But, more often than not, the result of adopting either plan will be the production of instability, for the reason that the meter leads are at high oscillating potential, and will probably be responsible for spurious couplings with some other circuit.

To avoid these troubles, it is a good plan to preclude the possibility of unwanted self-oscillation by short-circuiting the grid load of the valve concerned. But the component which constitutes this load may also be inaccessible, and it is useful to know that, so far as H.F., I.F. or detector valves are concerned (and these are the only ones likely to give trouble), the effect of a short-circuit may be brought about by connecting a large condenser (0.1 to 1 mfd.) between grid and cathode pins of the valve; this can be done most easily by the help of an adaptor, of which the condenser may form a permanent part. Although the condenser will pre-

vent the development of signal-frequency voltages across the grid circuit, it will not alter bias voltage, and so the reading of anode current will be normal.

UNTIL recently, the practice of connecting receiving apparatus directly to A.C. mains (not through a transformer) was to be strongly discouraged; it was contrary to I.E.E. regulations, and anyone following it ran the risk of invalidating his fire insurance policy. But now these regulations have been modified, and provided all the official precautions—and they are fairly stringent—are taken, the use of transformerless A.C. sets may at least be considered.

High Voltages Without Transformers

As a matter of fact, these changes will not affect the great majority of wireless amateurs, who will still prefer, for various reasons, to use a transformer. But in certain cases, particularly for temporary or experimental purposes when the mains voltage is low, it is useful to know that a rectified H.T. output of approximately twice the input A.C. voltage may be obtained from a simple circuit, such as that shown in Fig. 2, without a step-up transformer.

A metal rectifier of the voltage-doubling type, with a suitable rating as to voltage input and current output, may be employed. Of course, the receiver or apparatus to which rectifying equipment of this sort is connected must be completely isolated from earth so far as metallic connections are concerned; in fact, it must be treated as if it were operated from D.C. mains. Risk of accidental contact with any "live" parts must be avoided, and even those parts of the circuit that are usually regarded as being at low or earth

potential must be properly isolated and protected. Indeed, to be absolutely safe and to keep within the letter and spirit of the regulations, the precautions necessary are so extensive that it will be agreed that, after all, an improvised transformerless arrangement has few attractions except in special circumstances.

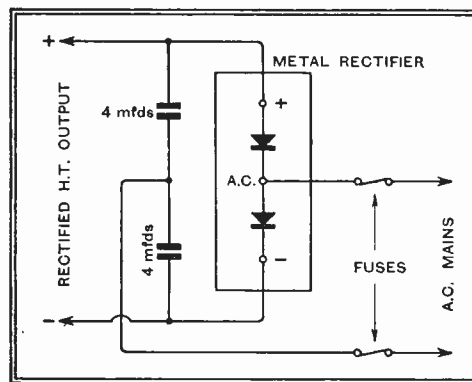

Fig. 2.—Voltage-doubling circuit for direct connection to A.C. mains.



Artillery "in action," assisted by a wireless-equipped car, during the Army manoeuvres in the Salisbury district.

More Radio Licences

OVER three-quarters of a million extra wireless licences have been taken out in Great Britain during the past year. The total number of licences in force at the end of August was 6,428,960, as compared with 5,654,400 in August, 1933.

Relays Illegal in France

RADIO relay systems are at present illegal in France. Encouraged by British and Belgian enterprises, several municipalities granted rights to private companies to organise relay systems in certain localities, but the Post Office has issued a declaration that all installations of this kind are against regulations.

The Death Ray Again

NOW that the Loch Ness monster appears to be on vacation, the French Press has resorted once more to the death ray. *La Dépêche de Toulouse* recently described how military authorities of most nations would soon possess the secret of a powerful death ray sufficient to annihilate 400 aeroplanes flying at a height of 250 miles.

Slow Morse from Ireland

THE Irish Radio Transmitters' Society is providing Morse practice for its members on Sundays from 11 a.m. B.S.T. on a wavelength of 84.2 metres. Transmissions consist of a general call to all Irish stations in telephony, followed by slow Morse from an automatic code machine. The call-sign is EI6F.

Reports of the transmissions will be welcomed by Mr. D. O'Farrell (EI6F), Park House, Booterstown Avenue, Co. Dublin.

"Large Studio" Too Small

NOW that the Norwegian studio orchestra has been augmented from nine to thirty musicians, the so-called "large studio" at Oslo is proving far too small, writes a correspondent. No arrangement of fans, however ingenious, can prevent an oppressive rise of temperature, and it has already been suggested that the orchestra should start a nudist colony in the studio! It has now been arranged that the augmented orchestra shall play in the main hall of the National Gallery.

Radio Agen Redivivus

RADIO AGEN, the small French station at Lot-et-Garonne, destroyed by fire in July last, is rapidly being rebuilt. Transmissions may be expected at the end of October.

Spoken Warning

A NEW Paris subway admits vehicles of limited dimensions only. At the Porte de la Villette a loud speaker has been installed connected to a photo-electric cell system which gauges the dimensions of every vehicle as it approaches. Frequently, as a van draws near, the speaker declaims in a loud voice: "Car too high. Pass to the right."

Electro-Radio-Biology

EVERY kind of radiation, from ultra-short waves to ultraviolet rays, X-rays, and cosmic rays, is being discussed at the first International Congress of Electro-Radio-Biology, opened last week in the Doge's Palace, Venice, by the Marchese Marconi.

It is hoped to find an entirely new approach to the practice of medicine. In his inaugural speech the Marchese Marconi warned his hearers of the difficulty of preserving a critical judgment regarding new means of restoring health, because health concerned all and roused men's imaginations. Men who had lost their health were prepared to pay anything to regain it, and consequently tremendous interests were involved.

The Amateur in America

IN the United States there are now exactly 46,390 licensed amateurs, according to the latest report of the Federal Communications Commission. America, therefore, has more transmitting amateurs than the whole of the rest of the world. The figures were 41,555 in 1933, 22,739 in 1931, and only 8,205 in 1924.

Why there should have been such a remarkable increase is an interesting question. It is contended that the depression left many American youths idle to pursue the hobby, but this would not explain how they came by the necessary funds! Other observers say it was due to a natural growth of interest in a fascinating field, from which many workers have later graduated into important positions in the radio and communications industry.

Current Events in Brief Review

Micro-Waves in Australia

EXPERIMENTS with micro-waves are now being conducted by Amalgamated Wireless (Australasia), Ltd. The company demonstrated apparatus using a wavelength of 50 centimetres at a recent radio exhibition in Melbourne.

Television Lecture in Manchester

A LECTURE on television is being delivered to-day by Mr. H. M. Dowsett, M.I.E.E., F.Inst.P., research manager of Marconi's Wireless Telegraph Co., Ltd., at a joint luncheon of the Manchester Athenæum Electrical Club and the Electrical Association for Women. We understand that there are a few tickets available, which can be obtained on application to Mr. E. Golland, Hon. Secretary, Manchester Athenæum Electrical Club, Princess Street, Manchester, 1.

Wavelength Parley in Lisbon

TOMORROW (Saturday) sees the opening of an important technical conference at Lisbon held by the Comité Consultatif Internationale des Radio Communications, commonly known as the C.C.I.R. This is an international Government advisory committee dealing with all phases of radio control with which Governments are concerned.

Of the few questions to be discussed likely to be of interest to broadcasting organisations there are the use of anti-fading aerials and single wavelength working by high-power stations.

German Licence Increase

GERMAN licences totalled 5,440,466 on September 1st, an increase of 82,047 over the figure of a month earlier.

The "Chronicle" Wireless Annual

THE twelfth edition of the "Chronicle" Wireless Annual is as attractive as its predecessors. This popular radio handbook of 180 pages should appeal more than ever to all classes of radio users, containing, as it does, articles touching on every phase of wireless and broadcasting. For the home set builder there are designs for a wide selection of receivers, ranging from a five-valve superset (designed by Mr. W. I. G. Page, B.Sc.) to an easily constructed two-valve quality receiver.

Such subjects as mains noises and their suppression, television, the cause and cure of interference, and home recording are dealt with succinctly in a series of short articles by experts. The Annual makes an excellent shillingsworth.

An "Ultra Shorts" Field Day

IVINGHOE BEACON, North Bucks, was the transmitting centre chosen by the Golders Green Radio and Scientific Society for direction finding experiments on five metres on Sunday last.

After initial adjustments had been carried out on the hill, the party broke up into some half-dozen groups, proceeding with their receivers in various directions from the transmitter.

Test signals were sent out for five minutes in each quarter of an



TWO-WAY TELEPHONY ON GLIDERS. A complete ultra short-wave transmitting and receiving outfit developed by the Hitler Youth organisation for use with gliders. The transmitter is on the left and receiver on the right. The youth in the centre is holding the microphone. British experimenters carried out wireless tests on gliders at Dunstable Downs on Sunday last.

Most Government delegations will include members of the technical staffs of the broadcasting companies, and for this reason the technical committee of the International Broadcasting Union will be able to meet in Lisbon during the conference to discuss several minor questions affecting wavelength exchanges. Mr. Ashbridge, chief engineer of the B.B.C., will be present.

The most consistently good results were obtained north and north-west of the transmitter, though a group six miles due west gave an exceptionally accurate map reading of the location of the transmitter. The majority of receivers were of the super-regenerative type.

On Wednesday next the Society will hold a meeting to collate and discuss results.

The Wireless World

FOREIGN PROGRAMME SUPPLEMENT

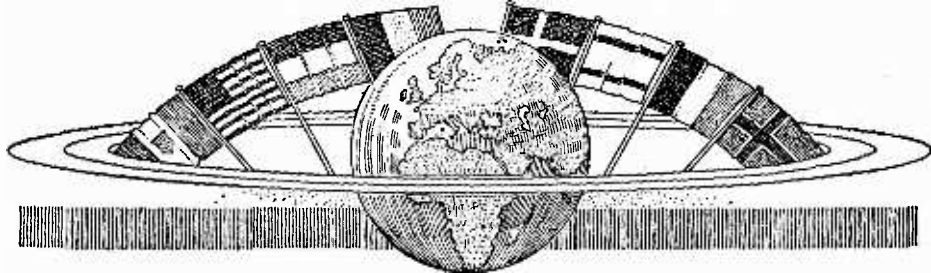

SUNDAY

SEPTEMBER THE TWENTY-THIRD

ATHLONE

565 kc/s, 531 metres; 60 kW. Relayed by Dublin, 1,348 kc/s, 222.6 metres; and Cork, 1,240 kc/s, 241.9 metres.—1.0 to 2.0 p.m., Records. 3.30 (approx.), Commentary on the All-Ireland Football Final, relayed from Croke Park. 8.30, Time Signal. 8.31, Sacred Music by St. Andrew's Boys' Choir, with Organ. 9.0, Concert of Sacred Music by the Station Orchestra. 9.30, Song Recital by Joan Kelleher (Mezzo-Soprano). 9.45, Sports Talk. 10.0, Shakespearean Drama, with Orchestra, presented by John Stephenson and Company. 11.0, Time Signal; News; Weather; Close Down.

BARCELONA

795 kc/s, 377.4 metres; 5 kW.—8.15 a.m., News; Records. 9.0, Chimes; Gym; Records. 9.20, News; Records. 10.0, Obituary. 12 Noon, Chimes; Weather. 1.0 p.m., Records. 2.0, Records. 2.30, Theatre Notes; Amusement Guide; Records. 3.0, Sextet Concert: Selection from The Circus Princess (Kálmán); Serenata (Pacheco); Spanish Dance, Tirana (Millán-Morabel); Overture, La Torre del Oro (Jiménez); Song from El carro de la Alegria (Campiña-Corral); Selection, El Hermano Lobo (Penella). 4.0, Programme for Hospitals. 5.0, Interval. 6.30, Talk in Catalan for Farmers. 7.0, Concert by the Station Orchestra. 7.30, Song Recital by Pascual Albero (Tenor). 8.0, Choral Concert. 9.0, Dance Music by the Hollywood Band, from the Hollywood Bar. 10.0, Chimes; Records. 11.45, Chess Lesson. 12 Midnight, Close Down.

BASLE.—Relays Beromünster.

BELGRADE

686 kc/s, 437.3 metres; 2.5 kW.—10.25 a.m., Programme Announcements. 10.30, Gym. 11.0, Records. 11.10, Water Level. 11.20, Records. 11.30, Talk. 11.59, Chimes. 12.5 p.m., Concert by the Station Orchestra. In the interval at 12.45, Announcements. 1.30, News; Time Signal. 3.0, Records of Folk Music. 3.30, Military Band Concert. 5.30, Choral Concert. 6.55, Time Signal; Programme Announcements. 7.0, Talk. 7.30, Announcements. 7.40, Concert of Folk Music by the Dusko Popoz Orchestra; Soloist, Nada Aleksandrovic (Songs). 8.10, Talk. 8.40, Variety Programme. 10.10, Time Signal; News; Sports Notes. 10.15, Concert by the Station Orchestra. 11.0, Songs with Orchestra. 11.30 (approx.), Close Down.

BERLIN

DEUTSCHLANDSENDER, 191 kc/s, 1,571 metres; 60 kW.—6.10 a.m., Motto. 6.15, See Hamburg. 8.0, Programme for Farmers. 8.55, Talk. 9.35, Interval. 10.5, Weather. 10.10, Talk. 10.20, Interval. 11.0, Recitation. 11.10, Weather. 11.30, Chamber Music on Records. 12 Noon, Greetings. 12.10 p.m., Concert from Königsberg. 2.0, See Stuttgart. 3.0, Chess Talk. 3.15, Concert by the Barnabas von Gezey and Hans Bund Bands (on Records). 4.0, Report: The European Light Athletic Championships, Germany v. France, at Magdeburg. 4.15, Dance Music from Breslau. In the intervals at 4.50, Weather Forecast for the Gordon Bennett Balloon Races; and at 5.0, Report of the German St. Leger Horse Races. 5.30, Military Band Concert, relayed from London. In the interval at 5.45, Report: The European Light Athletic Championships, Germany v. France, at Magdeburg. 6.30, Sports Report. 6.45, Rhinisch Anecdotes (Müller-Schlösser), with Records. 7.30, Adventurers and Settlers—Play (Schaffner). 8.5, See Cologne. 10.0, News. 10.30, Report: The World Professional Tennis Championships on Records. 10.45, Weather. 11.0, Weather Forecast for the Gordon Bennett Balloon Races. 11.10, Light Music and Dance Music from Cologne. 11.30, Popular Records.

BERLIN

FUNKSTUNDE, 841 kc/s, 356.7 metres; 100 kW.—6.0 a.m., Gym. 6.15 to 8.15, See Hamburg. 8.25, Announcement. 8.30, Reading. 8.55, Chimes. 9.0, Service from Potsdam Garrison Church. 10.0, Cathedral Chimes. 10.5, Weather. 10.10, Interval. 11.30, Chaitapin Records. 12 Noon, See Munich. 1.0 p.m., Announcements. 1.10, Concert from Cologne. 2.0, Announcements. 2.15, Records for Children. 3.0, Programme for Small-Holders. 3.45, Talk for Farmers. 4.0, Concert: Part I, Dance Music by an Accordion Band; Part II, Hans Busch Orchestra: March (Sudessi); Venetian Barcarolle (Tusa); Flirtation (Rau); Waltz (Lubbe); Intermzzo (Gillet); Serenade (de Micheli); Canzonetta for Violin (d'Ambrosio); Waltz, Deutsche Grusse (Jos. Strauss). In the interval at 5.0, Report: The World Professional Tennis Championships. 5.30, Military Band Concert, relayed from London. 6.0, Yorck, Count of Wartenburg—Sequence (Proebst). 6.35, Zigeunerlieder, Op. 103 (Brahms) by Margarete Heyer (Contralto). 6.55, Trio in D, Op. 6 (Peterka) by Hidegheti, Käthe Grandt, and Lehmann. 7.40, Sports Report. 8.0, Lortzing Opera Music; Concert by the Station Orchestra, Choir, and Soloists, Anni Frind (Soprano), Otto Albrecht (Tenor), Carl Schlotmann (Bass), and Georg Köppen (Bass); Conductor, Steiner; Extracts from: (a) Der Wälschler, (b) Die beiden Schützen, (c) Der Waffenschmied, (d) Czar and Carpenter, and (e) Undine. 9.20, Dance Music by the Small Station Orchestra. 10.20, News. 10.50, See Leipzig. 1.0 a.m. (Monday), Close Down.

BERNE.—Relays Beromünster.

BEROMUNSTER

556 kc/s, 539.6 metres; 60 kW.—7.30 a.m., Concert by a Male Voice Choir. 8.0, Interval. 10.0, Protestant Service. 10.45, Records of Chamber Music. 11.30, Literary Programme. 12 Noon, Concert by the Station Orchestra; Conductor, Neppach; Part I—Light Music. 12.30 p.m., Time; Weather; News. 12.40, Concert (contd.); Part II—Viennese Music. 1.30 to 2.30, Programme for Farmers. 4.0, Dance Music by the Station Dance Band. 5.30, Talk in Dialect: Stamp Collecting. 5.50, Records: Harvest Songs and Dances. 6.30, Talk: Japan. 7.0, Time; Sports Notes. 7.5, Records. 7.20, Dialogue: The Theatre (Rost). 7.50, Dramatic Programme. 9.0, News. 9.10, Talk by Carl Zuckmayr. 9.25, Concert by the Station Orchestra; Conductor, Gilbert. 10.15, Review of Swiss Books. 10.25, Sports Notes and Close Down.

BODEN.—Relays Stockholm. **BODO**.—Relays Oslo.

BRATISLAVA

1,004 kc/s, 298.8 metres; 13.5 kW.—6.30 a.m., See Prague. 8.30, Service from Kosice, 1,158 kc/s, 259.1 metres. 9.45, Records. 10.0, See Prague. 11.0, Military Band Concert from Trencanské Teplice; Conductor, Margold. 12 Noon, See Prague. 1.30 p.m., Talk for Farmers. 1.45, Water-Level. 1.50, Records. 2.0 to 2.30, Report on the start of the Stefánik Marathon. 4.0, Military Band Concert, relayed from Trencanské Teplice; Conductor, Margold. 5.30, Reading. 6.5, Egon and Emily—Dialogue (Morgenstern). 6.10,

Talk for Housewives. 6.15, Hungarian Transmission: Hungarian Country Music by Ant: Mazán (Songs) and R. Macudzinski (Pianoforte); Commentary by Nemeth. 6.55, See Prague. 7.35, Reading. 7.50, Sports Report. 7.55, In the Regions of Váh—Musical and Literary Sequence, by the Cast of the Slovak National Theatre. 8.45, Talk. 9.0, See Brno. 10.0, See Prague. 10.20, News in Hungarian; Sports Notes. 10.30, See Prague. 11.30, Close Down.

BREMEN.—Relays Hamburg.

BRESLAU

950 kc/s, 315.8 metres; 60 kW. Relayed by Gleiwitz, 1,231 kc/s, 243.7 metres.—5.0 a.m., Hymn; Motto; Records. In the interval at 5.40, Time; Weather. 6.10, Time; Weather. 6.15, See Hamburg. 6.15, Motto. 8.25, Recital on Two 'Celli by Binnowsky and Bormann. 9.0, Chimes. 9.5, Protestant Service. 10.0, Recitations. 10.20, Choral Concert; Conductor, Pilatus. 11.10, Imaginary Conversations—Sequence (Paul Ernst), with Introductory Talk. 12 Noon, Concert by the Station Orchestra; Conductor, Rischka; Soloist, Bruno Janz (Violin). 2.0 p.m., News. 2.10, Legal Talk. 2.30, A Gramophone ABC (Steimbach) (arr. Freudenberg). 3.30, The Enchanted Chest—Play for Children, after an Old Chinese Fairy Story (Koller). 4.0, Dance Music. 5.30, Military Band Concert relayed from London. 6.30, Sports Report. 6.55, Reading. 7.20, Talk. 7.30, Topical Report. 8.0, Concert of Light Music by the Station Orchestra; Conductor, Topitz. 10.20, Time; News. 10.45, Light Music and Dance Music from Cologne. 1.0 a.m. (Monday), Close Down.

BRNO

922 kc/s, 325.4 metres; 32 kW.—6.30 a.m., See Prague. 8.30, Organ Recital by Budik, relayed from the Huss House. 9.0, See Prague. 9.15, Song Recital by Marie Fialova. 9.40, See Prague. 11.0, See Bratislava. 12 Noon, See Prague. 1.30 p.m., Talk for Farmers. 1.45, See Prague. 2.15, Record. 2.20, Programme for German Farmers. 4.0, See Bratislava. 5.30, Talk. 5.45, See Prague. 7.55, See Bratislava. 8.45, See Prague. 9.0, Revue (Konupka and Weis); Members of the National Theatre and Station Orchestra; Conductor, Bakala. 10.0, See Prague. 11.30 (approx.), Close Down.

BRUSSELS (No. 1)

620 kc/s, 483.9 metres; 15 kW.—10.0 a.m., Request Records. 11.0, Orchestral Concert; Soloist, Rubeau (Tenor). 11.55, Weather. 12 Noon, Records of Light Music. 12.30 p.m., Monologues by Hélène Lefèvre. 12.40, Records. 1.0, News. 1.10, Concert by the Radio Orchestra; Soloists, Durand (Trumpet) and Anita Touret (Songs). 2.0, Interval. 5.0, Dance Records. In the interval, Football Results. 6.0, Pianoforte Recital by Lambert Wilmet: Allegro appassionato, Op. 4 (Seriabian); Le petit âne blanc from Histoires (Ibert); Two Impromptus, Nos. 1 and 3, Op. 10 (Absis). 6.15, Orchestral Concert: Overture, Boccaccio (Suppé); Waltz, L'étoile polaire (Waldteufel); In the American Style (Fischer); Selection from Mirella (Gounod); Le flûte de Pan (Mouquet); Suite orientale (Grieg); Spiel kamaraden (Jessel). 7.15, Religious Address. 7.30, News. 8.0, Concert of French Opera Music by the Symphony

Orchestra; Soloists, Angenot (Tenor) and Raidich (Bass): Overture, Le roi d'Ys (Lalo); Tenor Aria from L'attaque du moulin (Bruneau); Ballet Music from Lakmé (Delibes); Bass Aria from Louise (Charpentier); Ballet Music from Samson and Delilah (Saint-Saëns); Flower Song from Carmen (Bizet); Meditation from Thaïs (Massenet); Bass Aria from Mignon (Thomas); Waltz from Faust (Gounod). 9.0, Recitations. 9.15, Concert by the Symphony Orchestra; Soloists, Engenot (Tenor) and Raidich (Bass): Ronde wallonne (Jongen); Tenor Songs; Entracte from Jean Michel (Dupuis); Bass Songs, (a) Deep River, (b) Ol' Man River (Kern), (c) Les berceaux (Fauré), (d) L'amour de moi (Piercol); Le sonnet d'une nuit d'hiver (De Boeck). 10.0, News. 10.10, News. 10.15, Dance Music by Schnyder's Band. 12 Midnight, Close Down.

BRUSSELS (No. 2)

932 kc/s, 321.9 metres; 15 kW.—Programme in Flemish.—10.0 a.m., Orchestral Concert; Soloist, Rubeau (Songs). 11.0, Records. 11.57, Weather. 12 Noon, Concert by the Radio Orchestra; Soloists, Misson (Violin) and Anita Touret (Songs). 1.0 p.m., News. 1.10, Pianoforte Recital by Mme. Monden-Longerstaey: Chaconne (Bach-Busoni); Etude in E (Chopin); Prelude in A (Debussy); Toccata (De Boeck); Rhapsody No. 11 (Liszt). 1.30, Records. 2.0, Interval. 5.0, Sonata Recital by Mme. Husson-Michaux (Pianoforte) and Frezin (Cello): Sonata in C (Handel); Grand Sonata (Loillet); Sonata in F (Porpora). 5.30, Sports Results. 5.33, Dance Records. 6.30, Viola d'amore Recital by Distelmans: Suite (Milandra); Prelude (Hammer); Conte (Fanusis); Bohemian Dance (Meyer). 6.50, Symphony No. 8 (Beethoven), on Records. 7.15, Religious Address. 7.30, News. 7.55, Music Review. 8.0, Concert by the Radio Orchestra and a Vocal Quartet; Soloist, Boyarine (Balalaika). 8.45, Recitations. 9.0, Orchestral Concert (contd.). 10.0, News. 10.10, See Brussels No. 1. 12 Midnight, Close Down.

BUCHAREST

823 kc/s, 364.5 metres; 12 kW.—10.30 a.m., Religious Notes. 10.45, Sacred Music. 11.0, Concert by the Station Orchestra: March (Elliot); Waltz (Zeller); Gavotte (Lincke); Dance of the Hours, from La Gioconda (Ponchielli); Ballet Music from La Source (Delibes); Piece (Aston). 12 Noon, Water Level; Records. 12.45 p.m., Amusement Guide; Talk on Modern Music. 1.15, Time; Weather; News. 1.40, Records of Light Music. 4.0, Programme for Country People. 5.0, Dance Music by the Blue Star Jazz Band. 6.0, Time; Weather; News. 6.15, Dance Music. 7.0, Educational Programme. 7.15, Records. 7.45, Talk. 8.0, Concert by the Station Orchestra: Overture, Tancredi (Rossini); Suite, Russian Scenes (Bantock); Selection from Grisélidis (Massenet); Selection from The Little Dutch Girl (Kálmán); Haydn Potpourri (Tavan). 8.40, Wagner Song Recital by Aida Helta: Im Treibhaus; Schmerzen; Träume; Aria from Tannhäuser. 9.0, Sports Notes. 9.10, Concert by the Station Orchestra; Soloist, Teodoru (Violin); Piece (Akerman); Waltz (Strauss); In a Monastery Garden (Ketybey); Le monastère de Saint Honorat (Kostal); Potpourri of Popular Songs (Pashill); March (Schmelling). 10.0, News.

BUDAPEST

546 kc/s, 549.5 metres; 120 kW.—9.15 a.m., News. 10.0 Roman Catholic Service. 11.0, Protestant Service. 12.30 p.m., Weather. 12.40, Mendelssohn Concert by the Opera House Orchestra. Conductor: Fridl. Overture, Ruy Blas; Extract from A Midsummer Night's Dream; Spring Song; The Scottish Symphony. 2.0, Hungarian Song Recital by

MUNICH

740 kc/s, 405.4 metres; 100 kW. Relayed by Augsburg and Nürnberg, 1,267 kc/s, 236.8 metres.—6.15 a.m., See Hamburg. 8.15, Wireless Notes. 8.45, Trio for Pianoforte, Oboe and Viola (Adolf Ruthardt). 9.30, Protestant Service. 10.10, Chimes. 10.15, Reading. 10.40, Vocal and Instrumental Concert. 11.20, Michelangelo — Sequence (Kühne-Hellmessen). 12 Noon, Military Band Concert from the Feldherrnhalle. 1.0 p.m. (from Nürnberg), Orchestral Concert; Conductor, Böhm. 2.0, Time; Weather; Programme Announcements. 2.10, Talk for Farmers. 2.30, Records: Opera and Light Music. 3.20, Zwerz Nase—Play (Emma Hentes and Lydia Schulenburg) with Music by Fuchs. 4.0, See Berlin (Funkstunde). 5.30, Talk: Robert Peary's Expedition to the North Pole. 5.45, See Berlin (Deutschlandsender). 6.0, Harvest Song.—Literary and Musical Sequence (Müller-Albrecht). 6.40, Wessobrunn in the Autumn—Sequence (Schröder-Justin). 7.30, Variation and Fugue on a Beethoven Theme for Two Pianofortes (Röger), by Ludwig Kusche and Ludwig Schmidmeier. 8.0, Weather; Sports Report. 8.10, Das verbotene Lied—Singspiel in Three Acts (Werther). 10.0, Time; News. 10.30, Dance Music by the Station Dance Band. 12 Midnight, Close Down.

NAPLES.—Relays Rome. NOTODDEN.—Relays Oslo.

OSLO

260 kc/s, 1,154 metres; 60 kW. Relayed by Hamar, 519 kc/s, 578 metres; and Jeløy, 6,990 kc/s, 42.92 metres.—10.5 a.m., Symphony No. 7 in A (Beethoven) on Records. 5.15 p.m., Orchestral Concert: Overture, Egmont (Beethoven); Waltz (Waldteufel); Suite No. 2 from L'Arlesienne (Bizet); Lichtertanz (Rubinstein); Humoresque (Dvorák); Paso doble (Hajos). 6.15, Talk. 6.45, Sibelius Pianoforte Recital by Kosti Vehanen: Impromptu in G Minor; Andantino in F; Arabesque; Valse chevaleresque; Five Songs: (a) The Village Church, (b) The Fiddler, (c) The Oarsman, (d) The Storm, (e) In Mournful Moon. 7.15, Weather; News. 7.30, Time Signal. 7.31, Reading by Hank Aabel. 8.0, Variety Items. 8.30, Programme for Young People: Talk; Reading; Music. 9.40, Weather. 9.45, News. 10.0, Topical Talk. 10.15, Sports Notes. 10.30, Trio Concert of Old Dance Music. 11.0, Dance Records. 12 Midnight (approx.), Close Down.

OSTERSUND.—Relays Stockholm.

PARIS

POSTE PARISIEN, 959 kc/s, 312.8 metres; 100 kW.—10.0 a.m., Press Review. 10.20,

SEPT. 23rd SUNDAY continued

Announcements. 10.25, Records. 11.20, Concert. 11.50, Records: Extracts from Monsieur Papillon (Mouet, Lafarge and Favre). 12.5 p.m., Interlude by Kito, the Clown. 12.15, Records of Orchestral Music. 12.45, News. 12.50, Song Records of Paul Weill. 1.20, Interlude. 1.30, Soloist Programme. 2.0, Interval. 5.0 to 7.0, Programme in English arranged by the International Broadcasting Company of London. 5.0, Band of H.M. Coldstream Guards (Gramophone Records). 5.15, Light Music. 5.30, Celebrity Concert (Gramophone Records). 6.0, Orchestral Music. 6.15, Dwellers in the Open Air. 6.30, Dance Music. 7.20, News. 7.25, Sports Notes. 7.35, Records: Polonaise in A flat (Chopin); Etudes in A flat and G (Chopin); Valse impromptu in A flat (Liszt). 7.50, Records of Kreisler and Chahapiu. 8.0, Interlude. 8.10, Le Voyageur et l'Amour—Play in Two Acts (Paul Morand). 8.45, Interlude. 8.55, Variety Programme. 10.20, News. 10.30 till Close Down, Programme in English by the I.B.C. 10.30, Light Music. 11.0, Old Favourites. 11.30, I.B.C. Goodnight Melody and Close Down.

PARIS

RADIO-PARIS, 182 kc/s, 1,648 metres; 75 kW.—7.0 a.m., Records. 7.15, Press Review; Weather. 7.45, Gym. 8.0, Records. 11.30, Organ Recital by Pierre Revel, from the Cavaillé Colle: Prelude and Fugue in A (Bach); Pastorale (Franck); Toccata in D minor (Bach). 12 Noon, Religious Address. 12.20 p.m., Records of Sacred Music: Chorale (Bach); Cantate Domino (Alain); Fugue in G minor (Bach). 12.30 p.m., Bilboquet. 12.45, Records: Serenade (Walden); O sole mio (Di Capua); Pas des écharpes (Chaminade); Extract from La Vie Parisienne (Offenbach). 1.0, Concert of Popular Music by Victor Pascal's Orchestra. 3.0, Variety Programme for Young People. 4.0, Records: Selection from La Bohème (Puccini); Swanee River (arr. Kreisler); Vieux airs limousins (Rouchaud); Le Retour du Marin (Liersot); Moorish Serenade (Chapi); The Nightingale (Alabiev); Saudades do Brasil (Milhaud); Enfleurement (Ganne); Partir avec vous (Clere); Chanson de la Esmeralda (Mexquita); Follets (Hasselmanns); Selection from Rose Marie (Friml); Dans la Fumée (Bos); Bells Across the Meadow (Kettelbey). 5.0, Socrate et sa femme—Comedy (Bauville). 6.0, Concert by Paul Dony's Orchestra. 7.0, Radio Paris Guignol. 7.30, Topical

Talk. 8.0, Concert of Light Music by André's Orchestra. Soloists: Mmes. Germaine Lix and Jeanne Montague, and MM. Jossy and Tibiana (Songs). In the interval at 8.30, Press Review; Weather, and at 9.15, News. 10.30, Dance Music by Goldy's Dance Band.

PITTSBURGH

KDKA, 980 kc/s, 305 metres; 50 kW. Relayed by W8XK on 48.86 metres and 25.27 metres.—3.0 p.m., Southernaires. 3.30, Samovar Serenade. 4.0, First U.P. Church, N.S. 5.15, Gould and Shefter. 5.30, Radio City Concert. 6.30, Highlights of the Bible. 7.0, South Sea Islanders. 7.30, Concert Artists. 8.0, Organ Recital. 8.30, Temple of Song. 9.0, Vesper, Seaside Church. 10.0, Roses and Drums. 10.30, Radio Explorer's Programme. 10.45, Mildred Dilling (Harp). 11.0, Those Three Girls. 11.15, Baseball Resumé. 11.30, International Tidbits. 12 Midnight, Siken Strings. 12.30 a.m. (Monday), Musical Art Programme. 1.0 to 6.0 a.m., Popular Programme.

PORSGRUND.—Relays Oslo.

PRAGUE

638 kc/s, 470.2 metres; 120 kW.—6.30 a.m., Gym.; Music; News. 7.0, Concert by the Karlsbad Municipal Orchestra, relayed from Karlsbad. 8.30, See Brno. 9.0, Talk. 9.15, Concert by a Cello Quartet: Requiem for Three Cellos and Pianoforte (Popper); Minuet (Beethoven); Adagietto from L'Arlesienne (Bizet); Serenade (Cassade); Intermezzo (Lalo); Scherzo (v. Goens). 9.40, Talk for Workers. 10.0, Pianoforte Suite (Kálik) by Emil Mikelka. 10.25, Talk and Readings: Jaromir Borecky. 10.55, Announcements. 11.0, See Bratislava. 12 Noon, Chimes. 12.5 p.m., News; Weather. 12.15, Light Music by a Miners' Band. 1.30, Programme for Farmers. 1.45, Sketch for Farmers. 2.15 to 2.25, Announcements. 4.0, See Bratislava. 5.30, Theatre Reminiscences by Bohuslav. 5.45, Records. 5.55, Arlecchino—Theatrical Capriccio (Busoni) by the Station Orchestra and Soloists: Conductor, Svoboda. 6.55, News and Weather in German. 7.0, News; Weather. 7.5, Recital of Italian Songs and Arias by Vittorio Weinberg (Baritone). The Shepherds (Pizzetti); Selection from Nebbie (Respighi); Aida (Recl); Arias from Otello (Verdi) and Andrea Chénier (Giordano). 7.35, Discussion: The Russian Theatre To-day. 7.55, See Bratislava. 8.45, Broman reads

from his own Works. 9.0, See Brno. 10.0, Time; News. 10.20, Record. 10.25, News and Sports Notes in German. 10.30, Dance Music by Osten's Jazz Band. 11.30, Close Down.

RJUKAN.—Relays Oslo.

ROME

Call 1RO, 713 kc/s, 420.8 metres; 50 kW. Relayed by Naples, 1,104 kc/s, 271.7 metres; Milan, No. 2, 1,348 kc/s, 222.6 metres; Turin, No. 2, 1,357 kc/s, 221.1 metres; and 2RO, 11,810 kc/s, 25.4 metres.—9.40 a.m., Announcements. 10.0, Programme for Farmers. 11.0, See Milan. 12 Noon, Bible Reading. 12.15 p.m., Interval. 12.30, Records. 1.5 to 2.15, See Milan. In the interval at 2.0, Time; News. 4.15, Talk. 4.30, Records; Sports Notes. 5.0, Vocal and Instrumental Concert: Lilia Salomone (Pianoforte), Elena Cheli (Soprano) and Giulio Zambonelli (Baritone): Pianoforte Solos: (a) Sonata No. 2 (Galuppi), (b) Sole mattino sul prato del Roccolo (Pizzetti), (c) Danse nègre (C. Scott), (d) Danze d'Ariele (Pick-Mangiagalli); Soprano Solos: (a) Italian Folk Songs Neretti (b) Gondole e chittarre (Bianchini), (c) Ninna-Nanna sulle campane di Barza (Bonaccorsi); Baritone Solos: (a) Aria from Faust (Gounod), (b) Aria from A Masked Ball (Verdi), (c) Prologue to I Pagliacci (Leoncavallo). 6.15 to 6.20, Weather. 7.30, Sports Notes; Announcements. 8.0 to 8.30, Programme in English arranged by the International Broadcasting Company of London: Music by Paul Whiteman and his Band (on Gramophone Records). 8.45, Donna Juanita—Comic Opera in Three Acts (Suppé). In the intervals, Talk; Announcements. After the Programme, News.

RUYSSELEDE

10,330 kc/s, 29.04 metres; 8 kW.—7.45 p.m., News in French. 8.0, See Brussels No. 1. 9.0, News in Flemish. 9.15, Close Down.

SALZBURG.—Relays Vienna.

SCHENECTADY

WGY, 790 kc/s, 379.5 metres; 50 kW. Relayed at intervals by W2XAF on 31.48 metres, and W2XAD on 19.56 metres.—7.0 p.m., Talkie Picture Time—Sketch. 7.30, Musical Programme. 11.45, Fitch Programme; Wendell Hall. 12 Midnight, Chase and Saboron Hour; Jimmy Durante. 1.0 to 4.30 a.m. (Monday), Popular Programme.

SOTTENS

677 kc/s, 443.1 metres; 25 kW.; and Geneva, 401 kc/s, 748 metres.—9.55 a.m., Chimes. 10.0, Protestant Service from Neuchâtel. 11.15, Relay from the National Costume Fête at Montreux. 11.45, Records: Chamber Music. 12.30 p.m., News. 12.40 (from Geneva), Records. 2.0, Interval. 3.0, The Valkyrie—

NOW AVAILABLE

AT HOME



NEW FULLER HEAVY DUTY DRY BATTERY

High capacity 45 volt units with 2-3 times the life of the ordinary H.T. Battery. For the largest multi-valve sets.



NEW FULLER HIGH CAPACITY 2 VOLT CELLS

Multiple thick plate type especially suitable for Multi-valve Radios and largest Radio-gramophones.

ABROAD

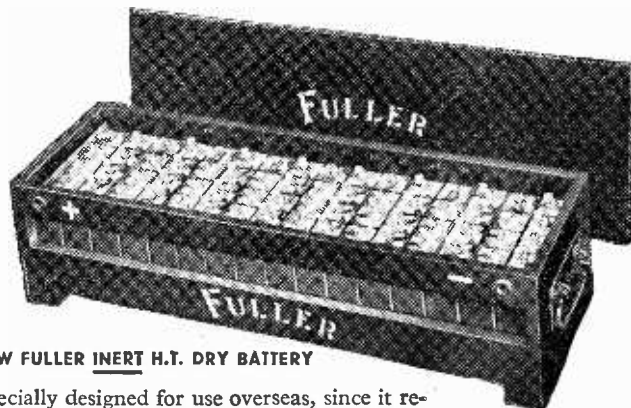

NEW FULLER INERT H.T. DRY BATTERY

Specially designed for use overseas, since it remains inactive until water is added to the cells. No deterioration in course of transit. Very high capacity. Supplied in any voltage.

Service Agents throughout the country

Agents throughout the World

FULLER BATTERIES

for every Purpose — everywhere

Fuller Accumulator Co. (1926) Ltd., Chadwell Heath, Essex.

Phone: Seven Kings 1200. Telegrams: "Fuller, Chadwell Heath."

"IT MUST BE 'ATLAS'"

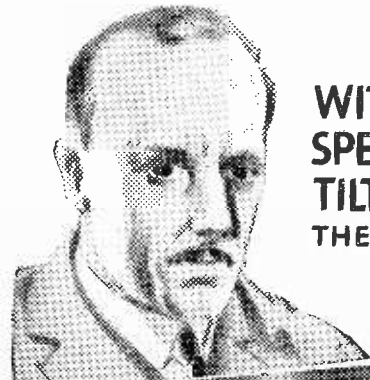

WITH THE **EXCLUSIVE SPECTRUM TUNING AND TILTING DIAL**—IF YOU WANT THE FINEST OF ALL RECEIVERS...

says the dealer.

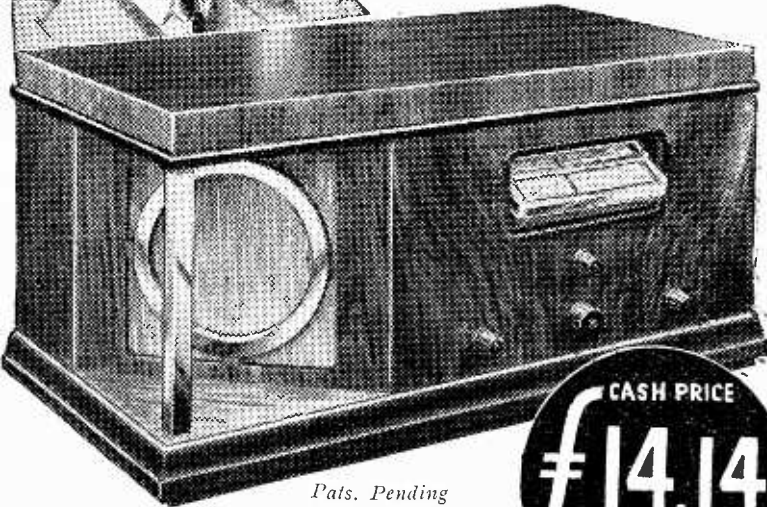

Pats. Pending
Prices do not apply to I.F.S.

CASH PRICE
£14.14
OR 32/6 DEPOSIT

No other receiver in the world gives you such luxuriously perfect superhet performance PLUS these THREE ESSENTIAL AND EXCLUSIVE "ATLAS" FEATURES — "SPECTRUM TUNING," the simplest and only certain station identification system yet devised, TILTING DIAL, a unique consideration of your comfort, and the superb "ATLAS" CABINET, the finest example of cabinet craftsmanship you have ever seen. Words cannot do justice to the new "ATLAS 7-5-8" Superhet—the sensation of Olympia. You must see, hear and test it for yourself. Ask your dealer to-day for a FREE demonstration and INSIST ON "ATLAS."

Everything you want in RADIO

7 Stages, 5 Valves, 8 Functions

For A.C. mains.
Moving Coil Speaker.
Band Pass Tuning.
Full Automatic Volume Control.
Tone Control.
Noise Suppressor.
Self-Contained Aerial.
Sockets for Pick-Up and Extra Speaker.
Guaranteed for 12 months.

H.P. Terms 32/6. deposit and 12 monthly payments of 25/- each.

PLUS "SPECTRUM TUNING" TILTING DIAL and the WORLD'S FINEST CABINET—THE THREE VITAL EXTRAS EXCLUSIVE TO "ATLAS."

ATLAS

"7-5-8"

SUPER-SUPERHET

POST THIS COUPON-NOW!

Messrs. H. Clarke & Co. (M cr.) Ltd., Patricroft, Manchester. Please send me full details of the new "ATLAS 7-5-8"

& LEARN ABOUT SPECTRUM TUNING

Name _____
Address _____

31 13

H. Clarke & Co. (M cr.) Ltd., Patricroft, Manchester. London: Bush House, W.C.2. Glasgow: I.F.S. Co Ltd., 38, Oswald St. I.F.S. Distrs.: R. Marks Ltd., 27, Upper Liffey St., Dublin.

SEPT. 23rd SUNDAY continued

Opera in Three Acts (Wagner). 5.0, Interval. 6.0, On m'a volé mon Portefeuille—Comedy in One Act (Raoux). 6.30, Song Recital by Raoul (Chatelain). 7.0, Religious Address. 7.30, Turina Concert by the Neuchâtel Trio. 7.55 (from Geneva), Sports Notes. 8.0, Boy Scouts Concert: A Vocal Quartet; Recitations; Choruses. 8.30, Concert by the Radio Suisse Romande Orchestra; Conductor, Echehard; Soloist, Marya Lucher (Songs). In the interval at 9.15, News. 10.0 (from Geneva), Sports Results. 10.15 (approx.), Close Down.

STOCKHOLM

704 kc/s, 426.1 metres; 55 kW. Relayed by Boden and Ostersund, 413.5 kc/s, 726 metres; Göteborg, 941 kc/s, 318.8 metres; Hörby, 1,131 kc/s, 265.3 metres; Motala, 216 kc/s, 1,389 metres; and Sundsvall, 601 kc/s, 499.2 metres.—9.0 a.m., Talk for Farmers. 9.30, Symphony No. 30 in E Flat (Mozart), conducted by Weingartner (on Records). 10.0, Talk in Esperanto, relayed from Uppsala. 10.30, Theatre Review. 11.0, Divine Service. 12.45 p.m., Weather. 3.0, Temperance Talk. 3.30, Recital of German Music by Emma Lampert (Songs) and Hans Lampert (Piano-forte): (a) Fieber Nacht (Wild), (b) Ruhe, meine Seele (R. Strauss), (c) Breit' über mein Haupt (R. Strauss); Piano-forte: Two Romances (Schumann); Songs (arr. Reinmann): (a) Die Linde im Tal, (b) Der Schwere Traum, (c) Swabian Folk Song. (d) Gut' Nacht. 4.0, Relay of the Reformation Monument Unveiling Ceremony at Orebro. 4.30 (from Göteborg), Programme for Children. 5.5, Records. 6.0, Evensong. 7.15, News. 7.35, Peasant Festival Programme from Skansen. 9.0, Military Band Concert. Conductor, Widner. 9.45, News. 10.0, Concert of Chamber Music by the Sibelius Quartet: String Quartet in C (Mozart); String Quartet in D Minor (Sibelius). 11.0 (approx.), Close Down.

STRASBOURG

859 kc/s, 349.2 metres; 15 kW.—9.30 a.m., Records. 10.45, Protestant Service in German. 11.30, Roman Catholic Service. 12 Noon, Announcements; Records. 12.15 p.m., Orchestral Concert; Conductor, de Villers; Soloists, Grégoire (Violin) and Pogoda (Piano-forte). In the interval at 1.0, Time; News. 2.0, Records. 3.0, Interval. 4.0, Records. 5.0, Programme from Paris (Ecole Supérieure), 437.1 metres. 6.0, Medical Talk. 6.15, Sports Talk. 6.30, Concert of Light Music; Conductor, Roskam. Soloist, Jean Weber (Saxophone). 7.30, Time; News. 7.45, Records. 8.0, Press Review in German; Lottery Results; Announcements. 8.30, Military Band Concert from the Esplanade, Metz; Conductor, Leroy; March, Louis XIV (Millot); Overture, Le Pré aux Cleres (Hérold); Selection from Lohengrin (Wagner); Three Norwegian Dances (Grieg); The Two Grenadiers (Schumann); Selection from Lakmé (Delibes); March (Allier); Six Dances in Old Style from Le Roi s'amuse (Delibes); Suite, Dolly (Fauré); Romance and Bolero (Dancla); Overture, The Merry Wives of Windsor (Nicolai); March (Blémant). In the interval at 9.30, Press Review. 10.30, Dance Music from Le Caveau de l'Aubette. 12 Midnight (approx.), Close Down.

STUTTGART

MUHLACKER, 574 kc/s, 522.6 metres; 100 kW.—6.15 a.m., See Hamburg. 8.15, Time; News. 8.25, Gym. 8.40, Announcements. 9.0, Roman Catholic Service. 9.45, Interval. 10.30, Recital by the Stuttgart Choral Society. Conductor, Müller. 10.50, Piano-forte Recital by Fritz Hübsh: Sonata in G Minor, Op. 81 (Rüdiger); Variations (Jos. Haas). 11.20, In the Forest—Gramophone Concert. 12 Noon, Military Band Concert, relayed from Ellwangen: March (Hessler); Overture, Platte Bursche (Suppé); Waltz from Eva (Lehar); Quadrille from Die Fledermaus (Joh. Strauss); Waltz Potpourri No. 2 (Robrecht); Potpourri; March (Curtis); March (Köhler). 1.0 p.m., Topical Talk. 1.15, Talk with Records. 2.0, Rübzahl—Play for Children (Dora Koreny-Scheck). 3.0, Pastor Werner and his Bruderhaus (Refuge) at Reutlingen—Sequence (Richter). 3.40, Zither Recital. 4.0, See Berlin (Funkstunde). 5.30, Spanish Guitar Music by Artur Faiss. 5.45, See Berlin (Deutschlandsender). 6.0, Reading. 6.20, Schumann Piano-forte Recital by Günther Homann: Kinderszenen; Sonata in G Minor, Op. 22. 6.50, Records. 7.30, Sports Report. 7.45, The Plamen Balloon—a Play about the Gordon Bennett Races (Georg Roch). 8.30, Concert of Italian Music. The Station Orchestra and Choir, a Guitar and Mandoline Orchestra, and Soloists: Iris Malpieri (Soprano) and Giovanni Barberini (Tenor). 10.0, Weather; Sports Report. 10.45, News. 10.35, Announcements. 10.45, Dance Music from Baden-Baden. 12 Midnight, See Frankfurt. 2.0 a.m. (Monday), Close Down.

SUNDSVALL.—Relays Stockholm.

TOULOUSE

913 kc/s, 328.6 metres; 10 kW.—11.0 a.m., Dance Refrains. 11.30, Songs; Overture

Music. 12 Noon, Opera Music. 12.15 p.m., Orchestral Music. 12.30, Roman Catholic Service. 12.45, Sound Film Music. 1.0, News. 1.15, Chansonnettes. 1.50, Cinema Organ Solos. 1.45, Protestant Service. 2.0, Amusement Guide. 6.0, News. 6.15, Opera Music; Aria from Rigoletto (Verdi); Duet from The Pearl Fishers (Bizet); Aria from The Damnation of Faust (Berlioz); Aria from Faust (Gounod). 6.30, Orchestral Music. 6.45, Songs. 7.0, Light Music. 7.15, Duets. 7.30, News. 7.45, Military Music; March (Holzmann); Washington Post (Sousa); Marche militaire (Saint-Saëns); Les petits grenadiers (Maquier); March (Beethoven). 8.15, Orchestral Music; Selection from Les deux pigeons (Messager); Overture, Der Freischütz (Weber); Airs on a Swiss Theme (Möler). 8.30, Humorous Sketches. 9.0, Concert Version, The Mastersingers—Opera (Wagner). 10.0, Sound Film Music. 10.15, News. 10.30, Soloist Programme. 11.0, Overture Songs: Songs from La Mascotte (Audran), La petite dame du train bleu (Pares and Van Parys), Passionnément (Messager), La Madone du pommier (Christine), and La fille de Madame Angot (Lecoq). 11.15, Hawaiian Guitar Music. 11.30, Light Music. 11.50, Orchestral Music. 12 Midnight, News. 12.5 a.m. (Monday), Au caveau de minuit—a Radio Fantasy. 12.15, Opera Music: Overture, Mignon (Thomas); Overture, The Barber of Seville (Rossini). 12.30 (approx.), Close Down.

TRONDHEIM.—Relays Oslo. TURIN.—Relays Milan.

VIENNA

592 kc/s, 506.8 metres; 120 kW. Relayed by Graz, 886 kc/s, 338.6 metres; Innsbruck, 519 kc/s, 578 metres; Klagenfurt, Linz, and Salzburg, 1,294 kc/s, 231.8 metres.—8.15 a.m., Time; Weather. 8.20, Gym. 8.40, Hints for the Week. 9.45, Records. 9.55, Ernst Arndt reads. 10.5, Concert by the Viennese Chamber Orchestra; Conductor, Audieth; Soloist, Schneiderhan (Violin); Overture, Euryanthe (Weber); Violin Concerto in G minor, Op. 26 (Bruch); Der Alcázar (Roehlitz); Les Préludes (Liszt). 11.20, Report of the Opening of the Grossglockner-Hochalpenstrasse, relayed from Fuschertörl. 12.45 p.m., Concert of Light Music by the Vienna Symphony Orchestra; Conductor, Holzer. 2.0, Report on the Austrian Marathon Race (on Records). 2.50, News. 3.0, Talk: Viennese Vinticulture. 3.20, Books for Young People. 3.45, Recital by the Mildner Quartet: Flute Quartet in A (Mozart); String Quartet in G minor, Op. 10 (Debussy). 4.25, Talk: International Waterways. 4.50, Commentary on the Second Half of the International Football Match, Austria v. Czechoslovakia, relayed from the Stadium. 5.45, Jazz Music by Leo Jaritz's Jazz Band. 6.25, Travel Talk: Crete and Greece. 6.50, Paul Praeger reads. 7.20, Announcements. 7.30, Lieder and Aria Recital by Sophie Kars (Soprano). 8.0, Motto. 8.5, Der Weistempel—Drama in Five Acts (Schönherr). 10.0, Balalaka Music by Dimitrii Tureroff. 10.30, News. 10.50, Concert by the Vienna Symphony Orchestra; Conductor, Holzer. 11.50, Records of Light Music. 1.0 a.m. (Monday), Close Down.

WARSAW

223 kc/s, 1,345 metres; 120 kW.—9.0 a.m., Hymn. 9.3, Records. 9.13, Gym. 9.23, Records. 9.30, News. 9.40, Records. 9.50, Hints for Housewives. 9.55, Programme Announcements. 10.5, Divine Service relayed from Lwow, 795 kc/s (377.4 metres); Sacred Music on Records. 11.57, Time. 12 Noon, Fantare from St. Mary's Church, Cracow. 12.3 p.m., Weather. 12.5, Theatre Review. 12.15, Concert by the Station Symphony Orchestra; Conductor, Mierzejewski; Soloists, Adamska (Cello) and Mossakowski (Songs); Leonora Overture No. 3 (Beethoven); Cello Concerto (Dvorak); Four Songs, Moniuszko Potpourri (Rybicki). In the interval at 1.0, Topical Talk. 2.0, Records: Light Music. 3.0, Agriculture Talk relayed from Poznan, 868 kc/s (345.6 metres). 3.15, Violin Recital by Erica Morini (on Records). 3.25, Market Prices. 3.35, Music on Two Piano-fortes (on Records). 3.45, Talk for Farmers. 4.0, Reading. 4.20, Song Recital by Michalowski. 4.45, A Story for Children. 5.0, Dance Music relayed from Lwow. 5.50, Book Reviews and Science Notes. 6.0, Dramatic Programme. 6.45, Talk for Young People. 7.0, Concert of Light Music by the Station Orchestra; Conductor, Nawrot; Soloist, Hoherman (Banjo and Accordion). 7.45, Programme Notes. 7.50, Topical Talk. 8.0, Concert by the Station Symphony Orchestra; Conductor, Latoszewski; Soloist, Gimpel (Piano-forte); Symphonic Poem; Tatra (Novak); Piano-forte Concerto in A minor (Schumann). 8.45, News. 8.55, Labour Exchange. 9.0, Humorous Programme from Lwow. 9.45, Sports Notes. 10.0, Technical Letterbox. 10.15, Announcements; Records. 10.30, Dance Music from the Gastronomica. 11.0, Weather; Aviation Notes. 11.5, Dance Music (cont'd).

ZURICH.—Relays Beromünster.

ATHLONE

565 kc/s, 531 metres; 60 kW. Relayed by Dublin, 1,348 kc/s, 222.6 metres; and Cork, 1,240 kc/s, 241.9 metres.—1.30 to 2.30 p.m., Time Signal; Exchange; Weather; Records. 4.0, Concert by the Gresham Instrumental Trio relayed from the Gresham Hotel; Soloist, Betty Byrne (Songs). 6.0, Programme for Children. 6.45, News. 7.0, Irish Lesson. 7.15, Talk on the Radio Exhibition. 7.30, Time Signal. 7.31, Sibelius and Sinding Concert by the Station Orchestra. 8.0, Sibelius and Dvorak Song Recital by Pearl McConkey. 8.15, Sinding and Sibelius Piano Recital by Tilly Fleischmann. 8.30, Talk by Lord French: Madagascar. 8.45, Concert by the Station Orchestra. 9.0, Song Recital by P. Kirwan (Tenor). 9.15, Talk: The Mystics in Drama. 9.45, Concert by the Station Orchestra. 10.0, Variety Programme. 10.30, Time Signal; News; Weather. 10.40, Traditional Fiddle Solos by F. McKenna. 10.50, Records. 11.0 (approx.), Close Down.

BARCELONA

795 kc/s, 377.4 metres; 5 kW.—12 Noon, Chimes; Weather. 1.0 p.m., Programme for Women. 1.45, Records. 2.0, Records. 2.30, Theatre Notes; Amusement Guide; Records. 3.0, Sextet Concert: Part I, Sound Film Music; Part II, Selection from Gipsy Love (Lehar); Intermezzo (Hupfermann); Spanish Dance No. 5 (Granados); Selection from Don Lucas del Cigarral (Vives); Melody from El Carro del Sol (Serrano); Rhapsody, El Ruisenor de la Huerta (Magenti). After the Concert, Labour Exchange Report. 4.0, Programme for Hospitals. 5.0, Interval. 7.0, Concert by the Station Trio; Selection from The Master Singers (Wagner); El Cuclillo (Duquino); Romance (Saint-Saens); Symphony Entr'acte (Desprez); Melody (Rachmaninov); Chanson breve (Demaret); Selection from Don Quixote (Massenet). In the interval at 7.30, News. 8.0, Request Records. 8.20, Sports Notes. 8.30, Exchange; Request Records. 9.0, Wireless Talk. 9.10, Aviation Notes. 9.20, Records; Geography and History Talk. 9.45, Press Review. 10.0, Chimes; Weather; Social Notes; Market Prices. 10.10, Humorous Review of the Week in Verse. 10.20, Concert of Sardanas. 11.0, Concert by the Station Orchestra. 11.30, Announcements. 12 Midnight, Dance Music from the Shang-hai Bar by the Melody Boys' Orchestra. 1.0 a.m. (Tuesday), News; Close Down.

BASLE.—Relays Beromünster.

BELGRADE

686 kc/s, 437.3 metres; 2.5 kW.—10.45 a.m., Programme Announcements. 10.50, Water Level. 11.0, Records. 11.59, Chimes. 12.5 p.m., Concert by the Station Orchestra. 12.45, Exchange; Announcements. 1.10, Concert by the Station Orchestra. 1.30, News; Time Signal. 4.0, Talk. 4.30, Concert by the Station Orchestra: March (Jakk); Overture (Binicki); Waltz (Marinkovic); Arabisches Gold (Rust); Suite (Travaglia). 6.25, Time Signal; Programme Announcements. 6.30, German Lesson. 7.0, Records. 7.10, Announcements. 7.20, Records. 7.30, Talk. 8.0, Werther—Opera (Massenet), relayed from the Theatre National, Zagreb, 1,086 kc/s, 276.2 metres. In the interval at 10.0, Time Signal; News.

BERLIN

DEUTSCHLANDSENDER, 191 kc/s, 1,571 metres; 60 kW.—5.30 a.m., Weather Forecast for the Gordon-Bennett Balloon Race. 5.45, Weather. 5.50, News. 6.0, Gym. 6.15, Motto. 6.20, See Hamburg. In the interval at 7.0, News. 8.0, Interval. 8.45, Gym. 9.0, Interval. 9.40, Report for Housewives. 10.0, News. 10.10, Report on Records: The German Excavations of Prehistoric Remains. 10.50, Physical Training for Schools. 11.15, Weather. 11.30 to 11.40, Weather Report for the Gordon-Bennett Balloon Race. 11.55, Weather. 12 Noon, See Stuttgart. 1.0 p.m., Cruising—Records. 1.40, Weather. 1.45, News. 2.0, Interval. 2.45, Greetings; Announcements. 3.0, Weather; Exchange. 3.15, Talk for Women. 3.40, Handicrafts for Young People. 4.0, See Munich. In the interval at 4.50, Weather for the Gordon-Bennett Balloon Race. 6.0, A Visit to the Nordic Society's Authors' Home at Travemuinde—Talks by well-known Writers (on Records). 6.25, Concerto for Harpsichord and Eight Instruments (Rasch) by Bruno-Hilte Reinhold and Members of the Station Orchestra; Conductor, The Composer. 6.55, A Poem; Weather. 7.0, Address by Reichminister Darré: The National-Socialist Agrarian Policy. 7.20, The Jupiter Symphony (Mozart) by the Berlin Philharmonic Orchestra conducted by Heinrich Laber (on Records). 7.45, A Visit to a Museum. 8.0, Motto; News. 8.15, See Munich. 8.45, Christian Man—Historical Play (Erwin von Wehrenalp). 10.0, News. 10.30, Talk: The Yawl Olympia. 10.45, Weather. 11.0, Weather Report for the Gordon-Bennett Balloon Race. 11.10, Concert from Hamburg. 12 Midnight, Close Down.

BERLIN

FUNKSTUNDE, 841 kc/s, 356.7 metres; 100 kW.—6.0 a.m., Gym. 6.15, Weather;

Prayers. 6.20, See Hamburg. In the interval at 7.0, News. 8.0 to 8.20, Gym. 8.30, Records; Announcements. 9.45, Cookery Hints. 10.0, News. 10.10 to 10.25, Market Prices. 11.25 to 11.30, Exchange. 12 Noon, Concert from Hamburg. In the interval, Weather. 1.0, News. 1.15, Records: Folk Music. 2.0, News. 2.15, Berlin Opera Announcements (on Records). 3.0 to 3.20, Exchange. 4.0, Concert of Light Music by the Station Orchestra; Conductor, Willy Steiner. 6.0, Announcements. 6.5, Report of the Hitler Youth Sports Tournament. 6.30, Chamber Music by Irgard Veidt. Ernst von Knorr and Hans Bastian (Violins) and Alexander Ecklebe (Pianoforte): Kleine Spielmusiken for Three Violins, Op. 13a (Wilhelm Malar); Thema, Variations and Fugue for Two Violins (von Knorr); Variations and Fugue for Pianoforte on a Reger Theme (Ecklebe), played by the Composer. 7.20, An Interview with Dr. Otto Kummel, Director of the Prussian State Museum. 7.40, Echoes of the Day. 8.0, News. 8.15, See Munich. 8.45, See Hamburg. 9.50, Cabaret Programme on Records. 10.20, News. 10.50, A Love Serenade. 12 Midnight Close Down.

BERNE.—Relays Beromünster.

BEROMUNSTER

556 kc/s, 539.6 metres; 60 kW.—12 Noon, Records. 12.29 p.m., Time Signal from Neuchâtel Observatory; Weather; News. 12.40, Records. 1.25, Time; Weather; Exchange; Interval. 3.30, Talk: Books for Women. 3.59, Time Signal from Neuchâtel Observatory. 4.0, Concert of Chamber Music by the Station Quartet; Soloist, Erna Niemann (Harp). 5.0, Saxophone Duets by Schwaller and Imark. 5.30, Pianoforte Recital by Arturo Milési, the Blind Pianist. 6.0, Records. 6.30, Programme for Young People. 7.0, Time; Weather. 7.1, Talk: Sunday Pursuits and Excursions. 7.10, Records. 7.30, Talk: Egypt. 8.0, Lecture-Recital: The Violin Sonata. 8.40, Divertissement No. 4 for Flute, Clarinet and Bassoon (Mozart). 8.50, Weather; News. 9.0, L'Arbre enchanté—Comic Opera in One Act (Gluck). 10.15 (approx.), Close Down.

BODEN.—Relays Stockholm. BODI.—Relays Oslo.

BRATISLAVA

1,004 kc/s, 298.8 metres; 13.5 kW.—6.0 to 7.15 a.m., See Prague. 9.45, Announcements. 9.50, See Prague. 11.0, Record. 11.5, See Moravská-Ostrava. 11.55, See Prague. 12 Noon, Talk for Farmers. 12.10 p.m., Local News in Slovak. 12.15, Record. 12.20, See Prague. 1.40, News and Weather in German and Hungarian. 1.50, See Prague. 2.0 to 2.5, Exchange. 3.15, Concert by the Station Orchestra; Conductor, Schimpl. 4.15 to 4.20, See Prague. 5.30, Literary Talk. 5.45, Pianoforte Recital by L. Holoubek. 6.10, Talk for Housewives. 6.15, Hungarian Transmission: Reading; Scarlatti Pianoforte Recital by Hrabussay; Legal Talk. 6.55, See Prague. 7.10, Song Recital by Emma Simandlová. 7.35, Talk: Slovak Industry. 7.50, Play in Three Acts by the Cast of the Slovak National Theatre. 9.25, Concert by the Vasica Jazz Orchestra. 10.0, See Prague. 10.45, News in Hungarian. 11.0, Close Down.

BREMEN.—Relays Hamburg.

BRESLAU

950 kc/s, 315.8 metres; 60 kW. Relayed by Gleiwitz, 1,231 kc/s, 243.7 metres.—5.0 a.m., Hymn; Motto; Records. In the interval at 5.40, Time; Weather. 6.0, Time; Weather; Gym. 6.25, See Cologne. In the interval at 7.0, Time; News. 8.0, Folk Song Records. 8.40, Gym. 9.0, Time; News. 10.10 to 10.40, Concert for Schools by a Mandoline and Late Orchestra. 11.30, Time; News. 12 Noon, Concert by the Silesian Symphony Orchestra. In the intervals at 12.30 p.m. and 1.30, News. 2.20, Exchange. 2.25, Announcements; Records. 2.50, Market Prices. 3.10, Book Review. 3.30 (from Gleiwitz), A Harvest Festival in Upper Silesia—Sequence in Dialect. 4.0, Concert by the Bad Charlottenbrunn Kurhaus Orchestra; Conductor, Alfred Oelfer; March (Seifert); Overture, Le brasseur de Preston (Adam); Selection from Der Bettelstudent (Müllhölzer); Waltz (Gungl); Ballet Suite (Popy); Clog Dance from Czar and Carpenter (Lortzing); Festival Overture, Viva Academia (Zimmer); Folk Song Potpourri (Schreiner); Waltz, Loreley Rheinklänge (Strauss); March (Urbach), 5.30, Weather; Market Prices. 5.35, Dialogue: Hunting with the Camera. 6.0, Topical Talk. 6.20, Talk with Records: A Journey to Vigo. 6.50, Announcements; Weather. 7.0, See Berlin (Deutschlandsender). 7.25, Recital of Japanese Songs (Zieritz) by Elisabeth Laube (Soprano). 8.0, News. 8.15, See Munich. 9.0, Music of the Pusztas; Recital by Karoly Kiss (Violin), Elemér Kiss (Cym-

bal) and Hattwig (Pianoforte). 9.40, Recital of Beethoven Sonatas by Georg Dohrn (Pianoforte); Sonata in A, Op. 2, No. 2; Sonata in C sharp minor, Op. 27, No. 2. 10.20, Time; News. 10.45, Gay Vienna—Concert by the Station Orchestra; Conductor, Ernst Topitz. 12 Midnight, Close Down.

BRNO

922 kc/s, 325.4 metres; 32 kW.—6.0 to 7.15 a.m., See Prague. 9.50, See Prague. 11.0, See Moravská-Ostrava. 11.55, See Prague. 12 Noon, Talk for Farmers. 12.10 p.m., See Prague. 1.30, Social Notes. 1.40, See Prague. 2.0 to 2.5, Market Prices for Farmers. 3.15, See Bratislava. 4.15 to 4.20, See Prague. 5.40, See Prague. 5.50, Hints for Housewives. 5.55 to 6.30, German Transmission: Readings (Goethe and Kreisler); Talk. 6.30, Recital of Slovak Songs by Milada Markova. 6.45, Legal Talk for Workers. 6.55, See Prague. 7.10, See Moravská-Ostrava. 7.35, See Prague. 11.0 (approx.), Close Down.

BRUSSELS (No. 1)

620 kc/s, 483.9 metres; 15 kW.—11.55 a.m., Weather. 12 Noon, Records. 1.0 p.m., News. 1.10, Orchestral Concert; Soloist, Alie, Meigrot (Songs); March (Turine); Waltz, Dolores (Waldteufel); Overture, Le pré-aux-clères (Hérold); Hymn to Saint Cecilia (Gounod); Selection from La fille de Madame Angot (Lecocq); Songs; Suite, Mascaraide (Lacôme). 2.0, Interval. 4.55, News. 5.0, Dance Records. 6.0, Science Talk. 6.15, Orchestral Concert; Soloist, Ferari (Violin); March, Montreal (Gilson); Overture, The Caliph of Bagdad (Boieldieu); Waltz (Luigini); The Tea Caravan (Niemann); Selection from La Navarraise (Massenet); Violin (Serenade (Drdla); Fête des accordailles (de Teyze); Suite breve (Henri Büsser). 7.15, Records. 7.30, Film and Theatre Review. 8.0, Concert by the Symphony Orchestra; Soloist, Berthe Albert (Songs); Prelude to Tristan and Isolde (Wagner); Symphony in D minor (Franck); Chansons enfantines (Mussorgsky); Suite, Dolly (Faure). In the interval at 8.15, Yvair Gilkin Programme: Talk and Readings. 10.0, News. 10.10, Dance Records. 11.0, (approx.); Close Down.

BRUSSELS (No. 2)

932 kc/s, 321.9 metres; 15 kW.—Programme in Flemish.—11.57 a.m., Weather. 12 Noon, Orchestral Concert; Soloist, Wigy (Violin): Adan Potpourri (Urbach); Waltz from The Arabian Nights (Joh. Strauss); Overture, La belle Hélène (Offenbach); Extase (Ganne); Violin: Fantasia on Hulleboreck's Songs (Wigy); Potpourri, Servus Wien (Dostal); March, King Cotton (Souza). 1.0 p.m., News. 1.10, Records. 2.0, Interval. 4.55, News. 5.0, Concert by the Symphony Orchestra; Soloist, Denise Biestraete ('Cello): Carnaval romain (Berlioz); 'Cello Solo: Idéal d'enfant (Keurvels); Passacaglia (Guillaume); Scherzo-Waltz (Guillaume); Melancolie (Delin); Ballet Music from Henry VIII (Saint-Saens). 5.45, Programme for Children. 6.30, 'Cello Recital by Denise Biestraete. 6.45, Request Records. 7.15, Talk. 7.30, Art Review. 8.0, Concert of Light Music by the Radio Orchestra. 8.45, Concert of Belgian Sound Film Music by the Radio Orchestra. 10.0, News. 10.10, Dance Records. 11.0 (approx.), Close Down.

BUCHAREST

823 kc/s, 364.5 metres; 12 kW.—12 Noon, Water Level; Records. 12.45 p.m., Amusement Guide; Records of Light Music. 1.15, Time; Weather; News. 1.40, Records of Light Music. 5.0, Concert by the Station Orchestra: Overture, Hamlet (E. Bach); Waltz from Casanova (Lincke); Andante (Beethoven); Nocturne (Clemens); Selection from La Juive (Halévy). 6.0, Time; Weather; News. 6.15, Concert by the Station Orchestra: Cockney Suite (Ketelbey); Berceuse (Squire); Two Pieces (Fétras); Foxtrot (Kochmann); Piece (Gylmard); Intermezzo (Siede); The Frog's Wedding (Beil). 7.0, Educational Programme. 7.15, Records. 7.45, Talk. 8.0, Concert of Chamber Music by the Metzner Quartet: Old English Folk Songs (Pochon); The Mill (Raff-Pochon); Andante in G (Dittersdorf); Quartet in E minor No. 2, Op. 44 (Mendelssohn); Old Black Joe (Foster-Pochon); Bagatelle (Scarlatescu-Jiann). 8.30, Talk. 8.45, Song Recital by Anne Gadiu; Aria from Il Trovatore (Verdi); Song (Curtis); Song (Burdes); Aria from L'Africaine (Meyerbeer); Aria from Madame Butterfly (Puccini). 9.15, Music relayed from the Poiana Carpatzi Restaurant. In the interval at 10.0, News.

BUDAPEST

546 kc/s, 549.5 metres; 120 kW.—6.45 a.m., Gym. 9.45, News. 10.0, Talks. 12 Noon, Chimes. 12.5 p.m., Trio Concert. 1.30, Band Concert. 2.40, Market Prices; Cookery Hints. 4.0, Programme for Students. 5.0, Concert

by the Berend Chamber Orchestra, relayed from Margaret Island. 5.45, Talk. 6.15, Pianoforte Recital by Irén Marik. 7.0, Talk: Hungarian Music. 7.35, Concert by the Lakatos Cigány Band. 8.35, Talk. 9.10, Wagner Concert by the Opera House Orchestra. Conductor: Otto Berg. Soloists: György Losonczy and Erzsí Bodo. Overture, Tristan and Isolde; Bacchanale from Tannhäuser; Selection from The Flying Dutchman; Extract from The Mastersingers; Fire Magic from The Valkyrie. 10.30, Weather. 10.50, Talk in Italian. 11.0, Dance Music by the Fejes Band.

CASSEL.—Relays Frankfurt.

COLOGNE

658 kc/s, 455.9 metres; 60 kW.—5.30 a.m., Greetings; Records. 6.5, Gym. 6.25, Concert by the Solingen Municipal Orchestra, relayed from the Town Hall, Solingen; Conductor, Werner Saam. In the interval at 6.50, Greetings; Time; News. 8.0, Time; Weather. 8.5, Gym. 8.20 to 8.30, Cookery Hints. 10.0, Time; News. 10.10, Recital by Will Smit (Violin) and Hans Haass (Pianoforte). 10.30, Talks. 11.30, Post Office Concert. 12 Noon, Concert by the Station Chamber Quintet: Javanese Dream (Ey-sold); Brise de mer (Leoncavallo); Two Movements from the Spring Suite (Nevin); Piece (de Micheli); Leggenda d'amore (Beccce); Tango (Meisel); Faszinata (Murzilli). 12.45 p.m., News; Greetings. 1.0, Concert by the Station Orchestra; Conductor, Julius Kahn; Soloist, Walter Schneiderhan (Violin); Prelude to Mignon (Thomas); Polonaise for Violin and Orchestra (Wieniawski); Paraguayan Suite (Brus-selmans); March (Preckher); Waltz, Marienklinge (Strauss); Greenland Suite (Juel-Fredricksen); Serenade (Glan); Intermezzo, Herbststimmung (Rust); Chromatic Gallop (Liszt). 2.45, Cattle Prices. 3.30, Exchange. 3.50, Topical Talk. 4.0, Opera Records. 5.0, Talk: The Paper-Coat of Rott. 5.15, Recital by Lotte Hellwig-Josten (Violin) and Hans Haass (Pianoforte); Sonata for Violin and Pianoforte, Il trillo del diavolo (Tartini); Spanish Dance (Sarasté); Slav Dance (Dvorak). 5.35 (approx.), Reading. 6.0, Gym. 6.20, Italian Lesson. 6.40, News. 6.50, Exchange; Sports Notes. 7.0, See Berlin (Deutschlandsender). 7.25, Weekly Review. 8.0, News. 8.15, See Munich. 8.45, Variety Programme. 10.0, Time; News. 10.20, Deutsches Liederspiel, Op. 14 (Heinrich von Herzogenberg) for Solo Voices, Mixed Choir and Pianoforte Duet. 11.0, Country Maidens—Literary Sequence with Old Chamber Music. 12 Midnight, Close Down.

COPENHAGEN.—Relays Kalundborg. CORK.—Relays Athlone. DANZIG.—Relays Königsberg. DRESDEN.—Relays Leipzig.

FECAMP

1,456 kc/s, 206 metres; 10 kW.—11.30 a.m. to 12 Noon, Programme in English arranged by the International Broadcasting Company of London: Happy Half-Hour; Light Orchestral Music. 12 Noon, Programme in French. 4.30 to 6.0 p.m., Programme in English arranged by the I.B.C. (London). 4.30, Dance Music. 5.0, Chichester, Bognor, Hastings and Eastbourne Concert, Part I—At the Seaside. 5.30, Southend Concert; Military Band Music. 6.0, Programme in French. 11.0 till Close Down, Programme in English arranged by the I.B.C. (London). 11.0, Talkie Time; Tunes from the Talkies and Shows. 11.30, In the Club this Week. 12 Midnight, Concert for Dalkite Listeners; Dance Music. 12.30 a.m. (Tuesday), I.B.C. Time Signal. 12.31, Dance Music. 1.0 a.m., I.B.C. Goodnight Melody and Close Down.

FLENSBURG.—Relays Hamburg. FLOR-ENCE.—Relays Milan.

FRANKFURT

1,195 kc/s, 251 metres; 17 kW.—5.45 a.m., Hymn; Time; Weather. 5.50, Gym. 6.40, Time; News. 6.50, Weather. 6.55, Concert by the Badenweiler Kurhaus Orchestra; Conductor, Albert Hitzig. 8.10, Weather. 8.15 to 8.35, Gym. 10.0, News. 11.0, Concert. 11.30, Announcements. 11.45, Social Notes. 12 Noon, See Stuttgart. 1.0 p.m., Time; News. 1.10, Announcements. 1.20, Records. 1.50, Time; News. 2.0, Song Records. 2.30, Industrial Review. 2.45, Time; Exchange. 2.55, Weather. 3.10, Discussion for Young People. 3.35, The Bachelor's Kitchen—Discussion, with Practical Hints. 3.45, Programme for Students. 4.0, See Stuttgart. 5.30, Anecdotes of Ludwig Finckh. 5.45, Sonata for Violin and Pianoforte (Konrad Kreutzer) by Otto Keller and Franz Diebold. 6.0, Our State Railways—Sequence for Young People (Herbert Kayser). 6.25, See Stuttgart. 6.45, Weather; Announcements. 7.0, See Berlin (Deutschlandsender). 7.30, Local Review. 7.45, Topical Talk. 8.0, Time; News. 8.15, See Munich. 8.45, Die Opernprobe—One Act Opera (Lortzing). 9.45, Autumn in Old Frankfurt Gardens—Sequence by Paul Laven, 10.20, Time; News. 10.35, Talk. 10.45, News. 11.0, Der Holzdieb—Comic Opera in One Act (Marschner). 12 Midnight, See Stuttgart. 1.0 a.m. (Tuesday), Close Down.

FREDRIKSSTAD.—Relays Oslo. FREI-BURG.—Relays Stuttgart. GENEVA.—Relays Sottens. GENOA.—Relays Milan. GLEIWITZ.—Relays Breslau. GÖTEBORG.—Relays Stockholm. GRAZ.—Relays Vienna. HAMAR.—Relays Oslo.

HAMBURG

904 kc/s, 331.9 metres; 100 kW. Relayed by Bremen, Flensburg and Hanover, 1,330 kc/s, 225.6 metres.—5.45 a.m., Time; Weather; Report for Farmers. 6.0, Gym. 6.15, Time; Weather. 6.20 (from Bremen), Concert by the Bremen Municipal Orchestra. Conductor: Reinhold Krug. In the interval at 7.0, Time; News; Talk. 8.0, Weather; Hints for Housewives. 8.10, Announcements; Records. 10.50, News. 11.0, Folk Songs. 11.30 (from Hanover), Concert by the Hanover Symphony Orchestra, relayed from Hanover Castle. Conductor: Otto v. Sosen. Soloist: Julius Schönherr (Violin). March (Liszt); Romantic Overture (Lilant); Salut d'amour (Elgar); Gavotte (Steinmann); Overture, Die Felsenmühle (Reissner); Das ganze Deutschland soll es sein (Blume); Gruss von Weserstrand (Krull); March (Krull). In the interval, Announcements; Talk. 1.0 p.m., Exchange. 1.15, Weather. 1.20, Light Music. 2.15, News. 2.30, Waltz Song Records. 3.0, Exchange. 3.40, Shipping and Aviation Notes. 4.0, See Munich. 5.30, The Girls' Sports Festival—Report for Young People. 6.0, Humorous Programme. 6.45, Exchange. 6.55, Weather. 7.0, Programme for Children, relayed from Rostock. 8.0, News. 8.15, See Munich. 8.45, Das Lied von der Glocke (Schiller), with Music by Hugo Distler. The Station Choir and a Boys' Choir. Conductor: Gregor. The Station Orchestra; Conductor: Maass. 10.0, News. 10.20, Address by Reichsminister Walter Darré: The National Socialist Agrarian Policy (on Records). 10.45, Records. 11.0, The Dance of the Instruments—Concert by the Station Dance Band. Conductor: Gebhardt. Wedding Dance of the Flamingos (Robert); Waltz for Three Piano-fortes; Frühlingsstimmen (Strauss-Gebhardt); Serenade for Oboe, Alto Saxophone, Trumpet, Drum and Piano-forte (Girafis); Nocturne for Alto Saxophone and Harp (Bumke); Foxtrot, Blue Night (Siegel); Foxtrot (Schmidseider); Serenade for Saxophone and Strings from Les Millions d'Arlequin (Drigo); Fantasia (Golwyn). 12 Midnight, Close Down.

HANOVER.—Relays Hamburg.

HILVERSUM

160 kc/s, 1,875 metres; 7 kW. (until 3.40 p.m.). Transmitted on Kootwijk, 50 kW., from 3.40 p.m. Programme of the General Broadcasting Society (A.V.R.O.).—7.40, Time; Records. 9.40, Time. 9.41, Service. 9.55, Records. 10.10, Recitations. 10.40, Recital by Piet van Egmoud (Organ) and Jeanne Ruygrok (Soprano). 11.40, Time. 11.41, Concert of Light Music by Kovaacs Lajos and his Orchestra. In the interval, Records. 1.40 p.m., Song Recital by Geard Holthaus (Baritone): Five Songs from Die schöne Müllerin (Schubert): (a) Das Wandern, (b) Der Nengierige, (c) Morgengruss, (d) Trockne Blumen, (e) Ungeduld; Records; Four Indian Love Lyrics (Woodforde-Finden); Records. 2.40, Concert by the A.V.R.O. Orchestra. Conductor: Nico Trepp. Overture, Preciosa (Weber); Symphony in B flat, No. 12 (Haydn); Grieg Potpourri (Haydn); Adagio for Strings (Lektu). 3.40, Interval. 3.55, Records. 4.10, Illustrated Music—Talk. 5.10, Concert of Light Music by the Rembrandt Theatre Orchestra. Conductor: Daaf Hartogs. 6.25, Records. 6.40, Recital by Nicolas Roth (Violin) and Egbert Veer (Piano-forte). Sonata, Op. 45 (Grieg); Mazurka in A minor (Chopin-Kreisler); Fereckles (Roth); Schön Rosmarin (Kreisler). 7.40, Records. 7.49, Time; News. 7.45, Records. 8.40, Dirk's Bridge Party—Play (de Sinclair). 9.10, Mozart Symphony Concert by the A.V.R.O. Orchestra. Conductor: Nico Trepp. Soloist: Georg Kuhlenkampf (Violin). Symphony in G minor; Violin Concerto in D. 10.10, Concert of Light Music by Cornelius Goldoban's Orchestra, relayed from the Carlton Hotel, Amsterdam. 11.40, Close Down.

HORBY.—Relays Stockholm.

HUIZEN

995 kc/s, 301.5 metres; 7 kW. (until 6.40 p.m.); 20 kW. from 6.40 p.m. Programme of the Christian Radio Society (N.C.R.V.).—7.40 a.m., Bible Reading. 7.55 to 9.10, Records. 10.10, Service. 10.40, Religious Address. 11.10, Talk. 11.40, Police Notes; Records. 12.10 p.m., Song and Piano-forte Recital by Mlle. Bolton (Contralto) and Mme. Hoogers-Höfeli. 1.10, Oboe and Piano-forte Recital by B. de Vries and Tump; Sonata in C minor (Händel); Duet (Laurischkus); Records; Concerto in F minor (Telemann). 1.40, Programme for Schools. 2.15, Records. 2.25, Talk for Housewives. 2.55, Records. 3.25, Interval. 3.40, Bible Reading and Sacred Music. 4.40, Records. 5.10, Organ Recital by Blaauw: Festival March (Becker); Serenade (Jensen); Meditation (Silver); Rondo in D (Mozart); Extract from Faust (Gounod); In the Mystic Land of Egypt (Ketelbey); Three Pieces (Loeschorn): (a) Schummerlied, (b) Gondeliers, (c) Saltarello. 6.10, Letter Box. 6.40, Police Notes; Church Notes. 6.55, Records. 7.10, Letter Box. 7.40, Orchestral and Choral Concert. Conductor: v. d. Hurk. Extract from Cantata No. 29 (Bach); O. hilf Christi (Hammerschmidt); Selection from L'Enfance du Christ (Berlioz); Three Pieces (Bansnenn): (a) Liebe den Herrn, (b) Der lieben Sonne Licht und Pracht, (c) Mein roep van Groenlands bergen; Song Cycle; Grieg Potpourri (arr. Urbach); Children's Symphony

SEPT. 24th MONDAY continued

(Romberg); Selection from Le Cid (Masse-et); Iland in Hand (v. Blon); Abschied von den Bergen (Carl); Gallop (Ramthor); Bergerette (Fétras); Die Zauberkarinette (Vollstedt); Arioso (Gumbert); Serenata d'Amalfi (Becco); Viva el Torero (Popy). In the interval at 8.40, Talk. 10.25, Records. 11.25 (approx.), Close Down.

INNSBRUCK.—Relays Vienna.

KALUNDBORG

238 kc/s, 1,261 metres; 75 kW. Relayed by Copenhagen, 1,176 kc/s, 255.1 metres; and Skamlebaek, 49.5 metres.—7.0 a.m., Gym. for Women. 7.15, Gym. 8.30, Divine Service from Copenhagen Cathedral. 11.0, Weather. 11.10, Fish Prices. 12 Noon, Chimes. 12.1 p.m., Music by the Bendix String Ensemble from the Wivex Restaurant. 2.50, Talk for Housewives. 3.0, Concert by the Radio Orchestra; Conductor: Keesen; Overture, Das Modell (Suppe); Waltz from Die geschiedene Frau (Fall); Suite, Summer Days (Coates); Ave maria stella (Grieg); Norwegian Bridal Procession (Grieg); Piedmontese Dance No. 1 (Sinigaglia); Spanish Serenade (Glazunov); Les nuages roses (Gillet); Traversée heureuse (Schmitt); Selection from The Rose of Stamboul (Fall); Gopak from The Fair at Sorotelninsk (Mussorsky). In the interval at 3.50, Poetry Reading. 5.0, Programme for Children. Reading from the Pickwick Papers (Dickens). 5.30, Exchange; Market Prices. 5.42, A Poem. 5.45, Talk: A Motor Tour of South America. 6.15, English Lesson. 6.45, Weather. 7.0, News. 7.15, Time Signal. 7.15, Discussion: Air Transport and its Possibilities. 7.30, Talk: The Press and Private Life. 8.0, Time. 8.1, Programme for Girls. 8.30, Italian Concert by the Chamber Orchestra; Conductor, Mailer: Sonata for Strings and Harpsichord (Vivaldi); Concerto grosso in F for two Violins, 'cello, Strings and Harpsichord (Scarlatti). 8.55, Back to the Land—Song Recital by Hallander Helleman, with Introductory Talk by Nelund. 9.30, Recital by Ole Frösing (clarinet) and Folmer Jensen (Piano-forte); Fantasietücke (Schumann); Theme with Variations (Weber). 9.55, News. 10.10, Extracts from Cagliostro in Wien—Operetta (Johann Strauss), by the Radio Orchestra; Conductor, Mailer. 11.0, Dance Music by the Aage Juhl-Thomsen Band from the National Scala. In the interval at 12 Midnight, Chimes from the Town Hall. 12.30 a.m. (Tuesday), Close Down.

KIEL.—Relays Hamburg. KLAGENFURT.—Relays Vienna.

KONIGSBERG

1,031 kc/s, 291 metres; 60 kW. Relayed by Danzig, 1,303 kc/s, 230.2 metres.—5.0 a.m., Records. 5.50, Weather. 6.0, Gym. 6.20, See Hamburg. In the interval at 7.0, News. 8.0, Service. 8.30, Gym. 9.5 (from Danzig), Broadcast for Schools: A German Family in North America—Extracts from the Letters of German Settlers. 10.40, News. 10.55, Weather. 11.30, See Hamburg. In the interval, Weather. 1.0 p.m., Time; Weather. 1.5, Records. In the intervals, News. 2.30, Exchange. 3.0, Market Prices. 3.15, Review of Periodicals. 3.45, A Puppet Play. 4.15, Concert by the Small Station Orchestra. Conductor: Wilcken. Part I, Music of Königsberg Composers. Suite, Erotica (Jensen); Romance (Maschke); Rauschenlied (Kursch); Ballet Suite (Hinfeld). Part II, Viennese Music. Overture, Prince Methusalem (Strauss); Two Songs from Die schöne Galathee (Suppe); Gavotte (Lincke); Glowworm Idyll (Lincke); Waltz from Eva (Lehár). 5.30, Talk: Iduma's Golden Apples. 5.50, Recital of Love Songs by Joachim Stein (Tenor); An Rose (Curschmann); Der Schiffer fährt zu Land (Curschmann); Chanson du printemps (Gounod); Das Ringeln (Chopin); Es muss ein Wunderbares sein (Liszt); Vögelin, wohin so schnell Franz; Keine Sorg um den Weg (Raff). 6.15, Market Prices. 6.25 (from Danzig), Talk: Herrensgräber. 6.55, Weather. 7.0, Sports for Young People. 7.30, Duet No. 1 in B flat for Violin and 'cello (Rolta); by Franz Schiffmann and Curt Sachs. 8.0, News. 8.15, See Munich. 8.45, See Hamburg. 10.0, News. 10.30, Topical Talk. 11.0, Concert by the Small Station Orchestra. Conductor: Wilcken. Overture, Raymond (Thomas); Waltz (Jos. Strauss); Pussaklänge (Sertiz); Leggenda d'amore (Becco); Selection from La Tosca (Puccini); Suite from La Source (Delibes). 12 Midnight, Close Down.

KOSICE.—Relays Prague. LAUSANNE.—Relays Sottens.

LEIPZIG

785 kc/s, 382.2 metres; 120 kW. Relayed by Dresden, 1,285 kc/s, 233.5 metres.—5.50 a.m., Report for Farmers. 6.0, Gym. 6.25, See Cologne. In the interval at 7.0, News. 8.0, Gym. 8.20, Records. 9.0, Interval. 9.40, Exchange. 9.45, Announcement; Weather. 10.10, Discussion in English for Schools: Sport in England. 11.0, Records; Announcements. 11.30, News. 11.40, Weather. 11.45, Programme for Farmers. 12 Noon, Concert

from Hamburg. 1.0 p.m., News. 1.10, Records; Folk Music. 2.0, News; Exchange; Weather. 2.15 to 2.45, Records; Hungarian Music. 3.0, Book Review. 3.40, Exchange. 4.0, Light Music by the Station Orchestra. Conductor: Blumer. Overture, Vintager's Bride (Nedbal); Ein Abend in St. Petersburg (Meyer-Helmann); Irish Rhapsody (Herbert); Waltz, Fesche Geister (E. Strauss); Selection from Madame Butterfly (Puccini). 5.0, Talk: August von Hofmann, the famous Chemist. 5.20 (from Dresden), Organ Recital by Alfred Hottinger: Prelude, Chaconne, and Fugue in D minor (Bach); Improvisation, Zum Abschied (Hottinger). 5.50, Exchange; Weather; Time. 6.0, See Berlin (Deutschlandsender). 6.20, Talk on the 8.45 Transmission. 6.40, Records: Folk Songs and Soldier Songs. 7.0, See Berlin (Deutschlandsender). 7.25, Chamber Music by Walter Kretschmar (Baritone, Guitar, and Lute), Hans Flynarzik (Violin), and Karl Meisner (Viola). Chamber Music in A Minor for Violin and Lute (Schlensog); Songs with Violin and Lute Accompaniment (Schlensog): (a) Vom singenden Tod, (b) Zigeunermelodie; Songs for Voice and Two Stringed Instruments (Göfferje): (a) Der hat vergeben, das ewige Leben, (b) Kein Feuer, keine Kohle; Sonata in D for Guitar, Violin, and Viola (Kretschmar). 8.0, News. 8.15, See Munich. 8.45, Der Sachsenspiegel—Three Scenes (Raymund Schmidt). 9.45, Quintet in A, Op. 81 (Dvorák). 10.20, News. 10.50, Concert of Light Music by the Station Orchestra. Conductor: Emil Lüh. 12 Midnight, Close Down.

LINZ.—Relays Vienna.

LUXEMBOURG

230 kc/s, 1,304 metres; 150 kW.—7.45 a.m., Records. 8.0, News in French; Record; News in German; Record. 12 Noon, Concert by the Station Orchestra; Conductor, Penis: Overture, Giralda (Adam); Waltz Dorfseelwalben aus Osterreich (Strauss); Mon Suzon (Clément); Selection from Les Cloches de Corneville (Planquette); Intermzzo No. 1 (Kalkmann). 12.30 p.m., News in French and German. 12.40, Concert (cont'd), Selection from The Bartered Bride (Smetana); Piece (Slytto); Selection from The Flower of Hawaii (Abraham); March (Blon). In the interval at 1.0, Exchange. 1.15, Records. 1.30, Exchange. 1.35, Records. 2.0, Exchange. 3.45, Exchange. 6.30, Concert of Light and Dance Music. 7.30, Racing Results. 7.35 till Close Down, Czech Evening. 7.35, Records. 8.0, News in French and German. 8.20, Concert by the Station Orchestra; Conductor, Penis: Overture, Carnaval (Dvorák); Suite No. 1 for Strings (Janacek); Berceuse (Kricka); Humoresque (Dvorák); At the Fair (Königsberger). In the interval at 8.30, Exchange. 9.15, Symphony Concert by the Station Orchestra; Conductor, Penis: Soloist, Casseclanne (Violin); Overture, Coriolanus (Beethoven); Concerto for Violin and Orchestra (Tchaikovsky); Suite No. 1 (Ibert). 10.25, Dance Records.

MADRID

EAJ7, 1,095 kc/s, 274 metres; 7 kW.—2.0 p.m., Chimes; Time; Weather; Light Music. 2.30, Sextet Concert. 3.0, Amusement Guide; Exchange; Popular Music. 3.30, Sextet Concert. 4.0, Popular Music. 4.30, Sextet Concert. 5.0, Interval. 6.0, Chimes; Light Music. 7.0, Announcements: Orchestral Concert: Prelude (Guridi); Piece (Rachmaninov); Waltz from Faust (Gounod); Peer Gynt Suite No. 1 (Grieg); Intermzzo (Granados); Turkish March (Mozart). 7.30, Exchange; Spanish Musical Comedy Extracts. 8.0, News; Recital of Old Music: Sonata in D (Leclair); The Harmonious Blacksmith (Handel); Turkish March (Mozart); Sonata in C (Bach); Tambourin (Rameau); Le Coucou (Daquin); Minuet from Don Giovanni (Mozart). 8.30, Sextet Concert. In the interval at 9.0, Sports Notes; at 9.30, Bull Fighting Notes; and at 10.0, Chimes; Time. 10.20, Extract from Manon—Opera (Massenet) on Records. In the interval at 11.0, News. 12.45 a.m. (Tuesday), News; Time; Announcements. 1.0, Chimes; Close Down.

MALMO.—Relays Stockholm.

MILAN

814 kc/s, 368.6 metres; 50 kW. Relayed by Turin, 1,140 kc/s, 263.2 metres; Genoa, 986 kc/s, 304.3 metres; and Florence, 610 kc/s, 491.8 metres.—7.30 a.m., Gym. 7.45, Time; Announcements. 8.0, Interval. 11.30, Concert by the Ches-Zanardelli-Cassone Trio. 12.30 p.m., Records. 12.45, News. 1.0, Time; News. 1.5, Concert by the Ferruzzi Orchestra. In the interval at 1.30, Records; Exchange. 2.15 to 2.25, Exchange. 4.35, News. 4.45, Programme for Children. 5.10, Dance Music. 5.55, Weather. 6.10, Notes for Farmers; Corn Prices. 7.0, Announcements. 7.15, News in Foreign Languages. 8.0, Time; News; Records. 8.30, Government Notes. 8.45, Request Programme. 9.45, Talk. 10.0, Variety. 11.0, News.

MONTE CENERI

1,167 kc/s, 257.1 metres; 15 kW.—12 Noon, News; Records. 12.29 p.m., Time; Weather. 12.33, Dance Records. 12.55, News. 1.3, Jazz Records. 1.15, Cookery Hints. 1.30, Interval. 3.59, Time. 4.0 to 6.0, See Bernmünster. 7.45, News. 8.0, Lecture Recital: The Violin Sonata. 8.40, Records: Divertimento No. 4 for Flute, Clarinet and Bassoon (Mozart). 8.50, News. 9.0, L'arbre enchanté—Opéra bouffe (Gluck). 10.15, Close Down.

MORAVSKA-OSTRAVA

1,158 kc/s, 269.1 metres; 11.2 kW.—6.0 to 7.15 a.m., See Prague. 9.50, See Prague. 11.0, Record. 11.5, Military Band Concert; Conductor, Michalek. 11.55, See Prague. 3.15, See Bratislava. 4.15 to 4.20, See Prague. 5.40, See Prague. 5.50, Talk. 6.0, News. 6.5, Reading. 6.20, German Transmission: Talk for Workers; German Lesson. 6.55, See Prague. 7.10, Dance Music by the Station Orchestra; Conductor, Musil; Soloist, Malina (Songs). 7.35, See Prague. 7.50, Impressions d'Italie (Charpentier) by the Station Orchestra; Conductor, Davis. 8.20, Summer-Lyric Comedy in Three Acts (Stranek). 10.0, See Prague. 10.45, Records. 11.0 (approx.), Close Down.

MOSCOW (No. 1)

174 kc/s, 1,724 metres; 500 kW.—5.0 a.m., News. 5.15, Fanfare. 5.45, Gym. 6.15, Musical Programme. 8.15, Programme for Children. 9.0, Musical Programme. 9.58, Time. 10.0, News. 10.15, Concert for Collectivist Farmers. 3.0, Programme Announcements. 3.15, Programme for Children. 3.58, Time. 4.0, News. 4.30, Concert of French Opereetta Music. 7.30, Violin and Song Recital. 9.0, Talk in German: The Changing Face of Russia. 9.55, Chimes. 10.5, Programme in English: Literary Programme; Letter Box. 11.5, Talk in Hungarian; Soviet Law.

MOTALA.—Relays Stockholm. MUHLACKER.—See Stuttgart.

MUNICH

740 kc/s, 405.4 metres; 100 kW. Relayed by Augsburg and Nürnb erg, 1,267 kc/s, 236.8 metres.—6.30 a.m., Gym. 6.45, Motto; Records. 7.15, Time; News. 7.25, Concert by the Rosenberger Chamber Quartet. 9.50, Gym. 10.10, Kasperl's Mountain Expedition—Play for Schools (Huber). 11.5, Market Prices. 11.15, Time; News. 11.30, Report for Farmers. 12 Noon, Records. 1.15 p.m., Time; News. 1.25, Concert by the Munich Concert Orchestra; Conductor, Hagel. 2.0, News. 2.20, Talk: Workers' Dwellings. 2.50, Programme for Children. 3.10, Spanish Folk Song Recital by Friedel Groß-Dünnerlein. 3.30 (from Nürnb erg). Reading. 3.50, Weather; Notes for Farmers. 4.0, Concert by the Small Munich Symphony Orchestra; Conductor, Bernhard Bischoff. 5.30, Talk, The Lutheran Bible. 5.50, Recital by Elisabeth Rosée (Soprano) and Wiedemann (Piano). 6.10, Book Review. 6.30, The Echo—Chamber Music for Two String Trios (Haydn). 6.50, Time; Weather; Notes for Farmers. 7.0, See Berlin (Deutschlandsender). 7.25, Hausteine Music for Zither by Laurenz Obermaier and Wally Messner. 8.0, News. 8.15, Transmission for all German Stations: Alpine Folk Music—Concert by Maria Seybold, Hans Sauer and Son (Harp and Dulcimer); The Riedinger Singers and the Bavarian Musicians; Conductor, Erich Kloss. 8.45, Piano-forte Recital by Friedrich Keitel: Concerto in D Minor (W. F. Bach); Waltz in C Sharp Minor (Chopin). 9.0, Concert of South American Music by the Station Orchestra; Conductor, Burle-Marx. 10.0, Time; News. 10.20, Programme to be announced. 11.0, Chamber Music by the Stubenrauch Trio.

NAPLES.—Relays Rome. NOTODDEN.—Relays Oslo.

OSLO

254 kc/s, 1,181 metres; 60 kW. Relayed by Hamar, 519 kc/s, 578 metres; and Jeløy, 6,990 kc/s, 42.92 metres.—11.15 a.m., Service. 11.50, Exchange. 12.55 p.m., Nauen Time Signal. 1.0 to 2.0, Records. In the interval at 1.15, Weather; Talk for Farmers; and at 1.45, Exchange. 5.30, Concert. 6.30, French Lesson. 7.0, Book Review. 7.31, Talk for Farmers. 7.30, Time Signal. 7.45, Talk for Farmers. 8.0, Programme for the Seventieth Anniversary of the Poet, Nils Collet Vogt; Talk; Reading. 8.30, The Seventh Scandinavian Music Festival—Sweden; Music by the Philharmonic Orchestra; Conductor, Tor Mann; Soloist, Gunnar de Frumerie (Piano-forte); Sinfonia breve (Nyström); Variations and Fugue for Piano-forte and Orchestra (de Frumerie). 9.15, Review of Foreign Affairs. 9.40, Weather. 9.45, News. 10.0, Topical Talk. 10.15, Records. 11.0 (approx.), Close Down. OSTERSUND.—Relays Stockholm.

PARIS

ÉCOLE SUPÉRIEURE, 695 kc/s, 431.7 metres; 7 kW.—12 Noon, Tourist Report. 12.15 p.m., Concert by the National Orchestra; Conductor: Rosenthal; Soloist: Gina Reilly (Songs); Overture, La Surprise de l'Amour (Poise); Suite, Legends of the Rhine (Gungl); Ballet Music from The Aventure de la Guimard (Messenger); Sons from La Mascotte (Aubran); Les Monsque-

SEPT. 24th MONDAY continued

laires au couvent (Verney), Madame (Christine); Songs; Italian Caprice (Tchaikovsky); Negro Spiritual (arranged Coleridge-Taylor); Concerto grosso No. 8 (Corelli); Pastoral from The Judgment of Midas (Cools); Ballet Music from Hamlet (Thomas); Overture, Prometheus (Beethoven). In the interval at 1.0, News. 2.0, Records. 5.45, Talk. 6.0, Talk: Economics. 6.30, News. 7.45, Talk. Aviation. 7.53, Assurance Societies Reports. 8.0, Sound Film Records. 9.5, See Vienna. After the Relay: News. 10.0, Dance Music.

PARIS

POSTE PARISIEN, 959 kc/s, 312.8 metres; 100 kW.—7.10 a.m., Fanfare; Records. In the interval at 7.30, News. 8.5, Concert. 8.20, News. 8.45, Cookery Talk. 12 Noon, Exchange. 12.5 p.m., Concert by the Station Orchestra; Overture, Mirella (Gounod); Suite, Espana (Albéniz); Bruyères (Debussy); Minuet (Boëllmann); Joyeuse marche (Chabrier); Invitation au voyage (Charpentier); Adoration (Fillipucci); Cosatouche (Dargomysky); Orchestral Suite (Chaminade); Pressnia (Cools); Pavane for Flute, Clarinet and Strings (Dupont); Selection from Manon (Massenet); Bouquet de valse (Bose). In the intervals at 12.25, News. 1.5, Exchange, and at 1.30, Exchange. 2.0, Exchange. 3.15, Exchange. 3.45, Exchange. 4.50, Exchange. 6.45, Exchange. 6.49, Records. 7.10, News. 7.30, Gardening Talk. 7.37, Records of Concert Waltzes: Espana (Chabrier); Méphisto Valse (Liszt). 7.50, Extracts from Figaro (Mozart) on Records. 8.0, Interlude. 8.10, Humorous Programme by Max Régulier and Company. 8.30, Interlude. 8.40, Exchange. 8.50, Concert by Gino Bordin and his Hawaiian Guitar Band. 9.30, Interlude. 9.40, Hot Jazz Records. 10.20, News. 10.30 till Close Down, Programme in English arranged by the International Broadcasting Company of London. 10.30, High Society. 10.45, Light Music. 11.0, I.B.C., Goodnight Melody and Close Down.

PARIS

RADIO PARIS, 182 kc/s, 1,548 metres; 75 kW.—6.45 a.m., Gym. 7.0, Records. 7.15, Press Review; Weather. 7.45, Gym. 8.0, Records. 12 Noon, Concert by Victor Pascal's Orchestra: Serenade (Fillipucci); Paqueta (Praciano); Das Veilchen (Mozart-Mateo); March (Rathke); Violin Solo: The Student passes by (Ibanez); Berceuse (Jarnefeld); Waltz (Jonasson); Lu Lu Fado (Milano); Pianoforte Solo: Song (Lehár); Nuit ensorcelée (Chopin-Mateo); Mazurka (Benatzky); La Lune qui danse (Aubry); Violin Solo: Song (Lehár); Extract from The Jewels of the Madonna (Wolf-Ferrari); Qu'avez vous fait de mon amour (Tibori); Czardas (Gungl); Song (Lehár); Gavotte (Siede); Waltz from The Chocolate Soldier (O. Straus). In the interval at 1.20, Exchange. 2.0, Interval. 3.45, Exchange. 6.20, Weather; Notes for Farmers; Exchange; Racing Results. 6.35, Talk: The Sahara Exhibition. 6.50, Book Review. 7.15, Film Review. 7.30, Topical Talk. 8.0, Un Perdreau de l'année—Play (Tristan Bernard). In the interval at 8.30, Press Review; Weather; and at 9.15, News. 9.30, Chamber Music: Septet with Trumpet (Saint-Saëns); Songs by Scarlatti, Beethoven and Schumann; The Trout Quintet (Schubert). 10.30, Dance Music by Les Cadets de France Orchestra.

PITTSBURGH

KDKA, 980 kc/s, 306 metres; 50 kW.—Relayed by W8XK on 48.86 metres and 25.27 metres.—3.0 p.m., Harvest of Song. 3.15, Sammy Fuller. 3.30, To-day's Children. 3.45, News; Cookery Hints. 4.0, Uncle Tom and Betty. 4.15, Tony Wons. 4.30, Melody Mixers. 5.0, Fields and Hall. 5.15, Charles Sears (Tenor). 5.30, Vic and Sade. 5.45, Hotel William Penn Orchestra. 6.0, Exchange. 6.15, Honourable Archie and Frank. 6.30, Farm and Home Hour. 7.30, KDKA Home Forum. 8.0, Radio Guild. 9.0, Betty and Bob. 9.15, Gale Page. 9.30, Exchange. 9.45, The Chicago Symphony Orchestra. 10.15, KDKA Kiddies' Klub. 10.30, The Singing Lady. 10.45, Orphan Annie. 11.0, Dan and Sylvia. 11.15, Baseball Résumé. 11.30, Comedy Stars of Hollywood. 11.45, Lowell Thomas. 12 Midnight, Amos 'n' Andy. 12.15 a.m. (Tuesday), Victor Merry-Makers. 12.30, Nancy Martin. 12.45, News; Dramatic Programme. 1.0 to 6.0, Popular Programme.

PORSCRUND.—Relays Oslo.

PRAGUE

638 kc/s, 470.2 metres; 129 kW.—6.0 a.m., Gym; Music; News. 7.15, Interval. 9.50, News. 10.5, News in German. 10.10, Record. 10.15, Play for Schools. 10.40, Records. 11.0, Record. 11.5, See Moravská-Ostrava. 11.55, Market Prices; Weather. 12 Noon, Time; Notes for Farmers. 12.10 p.m., Records. 12.20, News. 12.30, Dance Music by Kostal's Orchestra. 1.30, Labour Exchange. 1.40, Records. 1.50, Exchange. 1.55, Exchange and Weather in German. 2.0, Interval. 3.15, See Bratislava. 4.15 to 4.20, Exchange; Weather. 5.30, Talk on Economics. 5.40, Talk. 5.50, Announcements. 5.55, Record. 6.0, Programme for Farmers. 6.10, Programme for Workers. 6.20, German Transmission; Talk; Music Review. 6.55, News. 7.0, Time; News. 7.10, See Moravská-Ostrava. 7.35, Political Review. 7.50, Cittern Recital by Gleissner.

8.5, Double Face—Play (Emil Synek). 9.35, Recital by Zika (Violin) and Jaros (Cello): Duet in C, Op. 19 (Stanic); Duet, Op. 21 (Hlybler). 10.0, Time; News. 10.15, Records. 10.45, Talk in German: The International Congress of Philosophers in Prague. 11.0, Close Down.

RJUKAN.—Relays Oslo.

ROME

Call 1R0, 713 kc/s, 420.8 metres; 50 kW. Relayed by Naples, 1,104 kc/s, 271.7 metres; Milan, No. 2, 1,348 kc/s, 222.6 metres; Turin, No. 2, 1,357 kc/s, 221.1 metres; and 2R0, 11,810 kc/s, 25.4 metres.—7.30 a.m., Gym. 7.45, Time; Announcements. 8.0, Interval. 12.30 p.m., Records. 1.5, See Milan. In the interval at 1.30, Time; News. 2.15, Interval. 4.30, Programme for Boys. 4.50, News; Exchange. 5.0, Vocal and Instrumental Concert by Adriana Fusco (Pianoforte); Nino Mazziotti (Tenor); Carlo Platania (Baritone); Gualda Caputo (Soprano) and Luisaeta Castellazzi (Mezzo-Soprano); Suite (Lully); Tenor Solo: Recitative from Dafni (Mule); Baritone and Tenor Duet from The Force of Destiny (Verdi); Duets for Soprano and Mezzo-Soprano: (a) Duet from Cosi fan tutte (Mozart), (b) Duet from Der Freischütz (Weber), (c) Fandango (Pagans); Viyave and Gigue from Sonata in A (Paradisi); Baritone Aria from Dinorah (Meyerbeer); Tenor and Baritone Duet from La Bohème (Puccini). 5.55 to 6.10, Announcements; Corn Prices. 7.0, Announcements. 7.15, News in Foreign Languages. 8.0, Time; News; Records. 8.30, Government Notes. 8.45, See Milan. 9.45 (approx.), Talk by Ernesto Murolo. 10.0 (approx.), Symphony Concert; Conductor, Selvaggi. 11.0, News.

RUYSSSELEDE

10,330 kc/s, 29.04 metres; 8 kW.—7.45 p.m., News in French. 8.0, Records: Act I of Tosca—Opera (Puccini), and Ballet Music from Marouf—Opera (Rahaud). 9.0, News in Flemish. 9.15, Close Down.

SALZBURG.—Relays Vienna.

SAN SEBASTIAN

1,258 kc/s, 238.5 metres; 3 kW.—2.0 to 3.0 a.m. (Tuesday), Programme in English arranged by the International Broadcasting Company of London. 2.0, Selection of Waltzes. 2.30, Records. 3.0, I.B.C. Good-night Melody and Close Down.

SCHENECTADY

WQY, 790 kc/s, 379.5 metres; 50 kW. Relayed at intervals by W2XAF on 31.48 metres and W2XAD on 19.56 metres.—7.0 p.m., Dreams Come True; Barry McKinley (Songs). 7.15, Health Hunters. 7.30, Woman's Radio Review; Talk; Orchestra. 11.25, Exchange. 12 Midnight, Topical Talk. 12.30 a.m. (Tuesday), Voice of Firestone Garden Concert. 1.0 to 3.0 a.m., Popular Programme.

SOTTENS

677 kc/s, 443.1 metres; 25 kW.; and Geneva, 401 kc/s, 748 metres.—7.0 a.m., Gym. 7.15, Interval. 12.29 p.m., Time Signal from Neuchâtel Observatory. 12.30, News. 12.40, Concert by the Small Radio Lausanne Orchestra. Conductor, Moser. 1.0 Exchange. 1.5, Dance Music. 1.15, Light Music. 1.45, Dance Music. 2.0, Interval. 3.59, Time Signal from Neuchâtel Observatory. 4.0 to 6.0, See Bernmünster. 6.0, Programme for Children. 6.30, Programme for Women. 6.50, Concert by the Small Radio Lausanne Orchestra: Part I, Country Music. Part II, Light Music. 7.15, Dance Music. 7.30, Wireless Review. 7.40, Talk: The Agricultural Situation. 7.59, Weather. 8.0, Cello Recital by Altizer. 8.25, La Pie borgne—Comedy in One Act (Benjamin). 9.15, News. 9.25, Concert by the Small Radio Lausanne Orchestra; Soloist, Madeleine Dubuis. 10.15, Talk: The Work of the League of Nations. 10.30 (approx.), Close Down.

STOCKHOLM

704 kc/s, 426.1 metres; 55 kW. Relayed by Boden and Östersund, 413.5 kc/s, 726 metres; Göteborg, 941 kc/s, 318.8 metres; Hörby, 1,131 kc/s, 265.3 metres; Motala, 216 kc/s, 1,389 metres; and Sundsvall, 601 kc/s, 499.2 metres.—7.20 a.m., Gym. 7.45, Morning Service. 8.0, Weather. 12.15 p.m., Gym. for Schools. 12.30, Weather. 12.45, Exchange. 12.55, Time. 1.0, A Microphone Vltit to Mörby Castle. 1.30, Light Music and Reading. 5.0, Weather. 5.5, Folk Music. 5.45, Records. 6.45, Talk by Carl Wiman, relayed from Uppsala. 7.15, News. 7.30, Accordion and Pianoforte Recital. 8.0, Talk: Psychology. 8.30, Concert, relayed from Oslo. 9.15, Reading (Hemmer). 9.45, Weather; News. 10.0, Orchestral Concert of Light Music, relayed from Malmö, 1,312 kc/s, 228.7 metres. 11.0 (approx.), Close Down.

STRASBOURG

859 kc/s, 349.2 metres; 15 kW.—11.0 a.m., Variety Concert. 12 Noon, Records. 12.45,

News. 1.0 p.m., Time; Exchange. 1.5, Records. 5.0, Orchestral Concert from Rennes (P.T.T.), 1,040 kc/s, 288.5 metres. 6.0, Literary Talk: Lautier. 6.15, Readings from the Works of Alsatian and Lorraine Authors. 6.30, Orchestral Concert; Conductor, de Villers; Soloist, Marianne Ricklin (Songs); Overture, Rosamund (Schubert); Songs (Grétry); Jeux d'enfants (Bizet); Ballet Music from Lakmé (Delibes); Polovstian March (Borodin). 7.30, Time; News. 7.45, Records. 8.0, Press Review in German; Lottery Results; Announcements. 8.30, Records. 8.40, Programme to be announced. 9.5, See Vienna. 10.0 (approx.), Press Review.

STUTTIGART

MUHLACKER, 574 kc/s, 522.6 metres; 100 kW.—5.45 a.m., Hymn. 5.50, Gym. 6.15, Records. 6.40, Time; News. 6.55, Records. 7.25, See Munich. 8.10, Weather. 8.15, Gym. 8.35, to 8.40, Water Level. 9.0 to 9.15, Programme for Women. 10.0, News. 10.10, The Enchanted Pie—Fairy Play for Schools (Pocci-Hofmeier). 10.30, Recital of Classical Dances by Hedwig Kaiser (Pianoforte): German Dances (Schubert); Waltz in A Flat (Brahms); Hungarian Dance No. 1 (Brahms); Spanish Dance No. 5 (Granados); Seguidillas (Albéniz); Mazurka in B Flat (Chopin); Waltz in E Flat (Chopin). 11.0,



SIGNOR PARELLI, who, as musical director at Turin, is responsible for many of the operatic and orchestral programmes heard on the North Italian network.

Heckenröschén—Duet Cycle (Karl Eichorn) by Hermann Lingor (Tenor) and Emma Mayer (Contralto). 11.25, Announcements; Records. 11.55, Weather. 12 Noon, Light Music by the Philharmonic Orchestra; Conductor, Paul Schröder; Overture, An mein Vaterland (Alibont); Waltz, Münchner Kindl (Komzak); Prelude to Die Marketerdin (Humperdinck); Die Wachtпараде kommt (Eilenberg); March (Blankenburg); Overture, The Nuremberg Doll (Adam); Waltz, Die Werber (Lanner); Polka, Leichtes Blut (Strauss). 1.0, News. 1.20, See Frankfurt. 1.50, Time; News. 2.0 to 2.30, See Frankfurt. 3.40, Dialogue; Photography in the Service of German Race Propaganda. 4.0, Concert by the Philharmonic Orchestra. 5.30, Talk: Nature Preservation. 5.45, Reading of Lyrics (Oppenberg). 6.0, Report on Records: The Girls' Sports Festival at Tübingen. 6.25, French Lesson. 6.45, Dance Records. 7.0, See Berlin (Deutschlandsender). 7.30, Local Review. 7.40, Time; Weather; Programme for Farmers. 8.0, News. 8.15, See Munich. 8.45, See Frankfurt. 9.45, Concert Version of Schwarzwälder Kirsch—Operetta (Claus Valentini) by the Cast of the National Theatre, Mannheim; Introductory Talk by the Director. 10.20, Time; News. 10.35, Talk. 10.45, News. 11.0, See Frankfurt. 12 Midnight, Concert. 1.0 a.m. (Tuesday), Close Down.

SUNDSVALL.—Relays Stockholm.

TOULOUSE

913 kc/s, 328.6 metres; 10 kW.—8.0 a.m., Dance Refrains. 8.30, News. 8.35, Orchestral Music. 8.45, Operetta Songs. 12 Noon,

Orchestral Music. 12.15 p.m., Chansonnettes. 12.30, News. 12.45, Request Music. 1.0 p.m., News. 1.5, Military Music. 1.15, Opera Arias. 1.30, Accordion Music. 1.45, Sound Film Music. 2.0, News; Amusement Guide. 6.0, News. 6.15, Orchestral Music; The Roses (Métrá); Gipsy Waltz (Zubalov); Melody; The Blue Danube (Strauss). 6.30, Songs. 6.45, Soloist Programme. 7.0, Operetta Songs; Songs from Trois de la marine (Scott); Florestan I (Heymann); The Land of Soules (Lehar). Frasquita (Lehar), and Un soir de réveilion (Miretti). 7.15, Orchestral Music; Un peu d'amour (Silesu); Melody (Rubinstein); Les oiseaux de la forêt (Messier); Amina (Lincke). 7.30, News. 7.45, Sound Film Music. 8.15, Pianoforte Recital: Valse brillante No. 1 (Chopin); Prelude (Rachmaninov); Spanish Dance in D (Granados); The Butterflies (Zubalov). 8.30, Chansonnettes. 8.0, Military Music. 9.10, Carmen—Opera in Four Acts (Bizet). In the interval at 10.15, News. 11.50, Orchestral Music; Oublie-moi (Teleser); Spring Song (Sibelius); Potpourri (Jessel). 12 Midnight, News. 12.5 a.m. (Tuesday), Au cavaud de minuit—Radio Fantasy. 12.15, Argentine Band Music. 12.30 (approx.), Close Down.

TROMSDHEIM.—Relays Oslo. TURIN.—Relays Milan.

VATICAN CITY

15,120 kc/s, 19.84 metres; 10 kW. (Morning); 5,970 kc/s, 50.25 metres (Evening)—11.0 to 11.15 a.m., Religious Information in Italian. 8.0 to 8.15 p.m., Religious Information in Italian.

VIENNA

592 kc/s, 506.8 metres; 120 kW. Relayed by Graz, 886 kc/s, 338.6 metres; Innsbruck, 519 kc/s, 578 metres; Klagenfurt, Linz, and Salzburg, 1,294 kc/s, 231.8 metres.—9.0 a.m., News. 9.20, Market Prices. 9.30, Weather. 10.50, Water Level. 11.30, Records: Swiss Folk Music. 11.55, Weather. 12 Noon, Concert by the Vienna Symphony Orchestra; Conductor, Holzer; Soloist, Theo Salzmann (Cello). 1.0 p.m., Time; News. 1.10, Concert (contd.). 2.0, Announcements. 3.30, Time; Exchange. 3.50, Programme for Women. 4.10; News. 4.15, Reading for Young People. 4.40, Recital by Maria Hinko-Tunner (Soprano) and Maria Sabatin (Pianoforte). 5.10, Talk: Richard Wagner and Viennese Opera. 5.30, Records of Jack Hylton's Band. 6.15, Talk. 6.35, Talk: Western Culture. 7.0, Time; News. 7.20, Variety Programme. 8.0, Talk: The Tenth Anniversary of Ravag. 8.15, Programme to be announced. 9.5, Concert by the Vienna Symphony Orchestra; Conductor, Oswald Kabasta; Soloist, Therese Tröster (Pianoforte); Concertino for Pianoforte and Strings (Gál); Suite Op. 20 (Korncuth). 10.5, Report of the League of Nations Conference from Geneva. 10.25, News. 10.45, Concert of Viennese Operetta Music by the Vienna Symphony Orchestra; Conductor, Holzer; Overture, The Gipsy Baron (Strauss); Waltz from Das Veilchenmädel (Hellmesberger); Lass dir Zeit (Zeller); Overture, The Enchanted Castle (Müllöcker); March (Eysler); Overture, Der Schatzmeister (Ziehrer); Polka, Lieb' Mamachen (Weinberger); Waltz, Kind, du kamst tanzen (Fall); Songs, Das Glückel (Stolz); Hungarian Dance Suite, from Der Teufelsreiter (Kálmán); Overture, A Waltz Dream (O. Strauss); Waltz (Ascher); Overture, Wiener Frauen (Lehár). 11.45, Folk Music relayed from the Bürgertheater Restaurant. 1.0 a.m. (Tuesday), Close Down.

WARSAW

223 kc/s, 1,345 metres; 120 kW.—6.45 a.m., Hymn. 6.48, Records. 6.58, Gym. 7.8, Records. 7.15, News. 7.25, Records. 7.35, Hints for Housewives. 7.40, Announcements. 7.50, Light Music. 8.0, Interval. 11.57, Time. 12 Noon, Fanfare from St. Mary's Church, Cracow. 12.3 p.m., Weather. 12.5, Press Review. 12.10, Concert from Wilno, 536 kc/s, 559.7 metres. 1.0, News. 1.5, Song Records. 1.30, Interval. 3.30, Announcements. 3.45, Exchange. 3.50, Concert of Light Music by the Wilkosz Orchestra; Soloist, Konarek Korska (Songs); Foxtrot (Lazzerini); Waltz from Giuditia (Lehár); Piece (Carr); Three Songs; Slow Foxtrot (Petersburški); Tango, Campanola (Nowi); Serenade (Wroblewski); Tango, Senta (Cesoli); Two Songs; Foxtrot (Nesbit); Waltz (Clar); Tango (Murzilli); Foxtrot (Brown); Pasodoble (Bruguera). 4.45, German Lesson from Lwów, 795 kc/s, 377.4 metres. 5.0, Sonata in F, Op. 24, for Violin and Pianoforte (Beethoven), by Lili Hakowska and Jasienka. 5.25, Letter Box. 5.35, Song Recital by Plattó; Lorelei (Liszt); Song (Schumann); Der Nussbaum (Schumann); Zulejka (Szymanowski); Les astres (Noskowski). 5.50, Talk. 6.0, Letter Box. 6.10, Art Notes. 6.15, Banjo and Pianoforte Duets from Lwów. 6.35, Choral Records. 6.45, Programme for Children. 7.0, Around Poland with the Microphone. 7.25, Programme for Boy Scouts. 7.30, Reading. 7.45, Announcements. 7.50, Sports Notes. 8.0, Records. 8.40, Interval. 8.45, See Vienna. In the interval, News; Talk. 10.0, Talk. 10.15, Announcements; Light Music. 10.30, Dance Music from the Adria. 11.0, Weather. 11.5, Dance Music from the Adria.

ZURICH.—Relays Bernmünster.

ATHLONE

565 kc/s, 531 metres; 60 kW. Relayed by Dublin, 1,348 kc/s, 222.6 metres; and Cork, 1,240 kc/s, 241.9 metres.—1.20 to 2.30 p.m., Time Signal; Exchange; Weather; Records. 4.0, Concert by the Army Band. 6.0, Programme for Children. 6.45, News. 7.0, Talk in Irish. 7.15, Recitations (Crawford Neil) by M. Nisimblhaigh. 7.30, Time Signal. 7.31, Concert by the Station Orchestra. 7.45, Song Recital by Dorothy Griffith (Soprano). 7.55, Concert by the Station Orchestra. 8.10, Song Recital by Dorothy Griffith (Soprano). 8.20, Songs of the Counties by Cathal O'Byrne. 8.35, Harp Solos by Annie Fagan. 8.50, Variety by Eva Brennan and Company. 9.30, Recital of Irish Cello Music by A. L. Carew. 9.45, Irish Songs by Stan O'Brian. 10.0, Variety Programme. 10.30, Time Signal; News; Weather. 10.40, Records. 11.0 (approx.), Close Down.

BARCELONA

795 kc/s, 377.4 metres; 5 kW.—8.15 a.m., News; Records. 9.0, Chimes; Gym; Records. 9.20, News; Records. 10.0, Obituary. 12 Noon, Chimes; Weather. 1.0 p.m., Programme for Women. 1.45, Records. 2.0, Records. 2.30, Theatre Notes; Amusement Guide; Records. 3.0, News; Sextet Concert; Exchange. 4.0, Programme for Hospitals. 5.0, News. 7.0, Concert by the Station Trio: March (Fucik); Minuet (Ganne); Hymn to the Sun (Rimsky Korsakov); Selection from La Bohème (Puccini); Nocturne in B flat (Chopin); Piece (de Svéřac); Selection from Mephistopheles (Boito). In the interval at 7.30, News. 8.0, Request Records. 8.15, Sports Talk. 8.30, Exchange; Talk in Catalan. 9.0, Wireless Notes. 9.10, Anti-War Propaganda. 9.20, Records. 9.30, Geography and History Lesson. 9.45, Press Review. 10.0, Chimes; Weather; Social Notes; Exchange. 10.10, Variety Programme. 10.40, Concert by the Station Orchestra: Waltz (Waldteufel); Chanson triste (Tchaikovsky); March from Cydalise et le Chevre-pied (Pierné). 11.0, Schubert Song Recital by Carmen Gombau. 11.30, Concert by the Station Orchestra. 12 Midnight, Dance Music by the Melody Boys' Orchestra from the Shang-hai Bar. 1.0 a.m. (Wednesday), News.

BASLE.—Relays Beromünster.

BELGRADE

686 kc/s, 437.3 metres; 2.5 kW.—10.45 a.m., Programme Announcements. 10.50, Water Level. 11.0, Concert by the Station Orchestra. 11.59, Chimes. 12.5 p.m., Records. 12.45, Exchange; Announcements. 1.10, Records. 1.30, News; Time Signal. 4.0, Programme for Women. 4.30, Records. 5.0, Talk. 6.25, Time Signal; Programme Announcements. 6.30, Serbian Lesson. 7.0, Recital by Miroslava Binicki (Songs) and Milan Dimitrijevic (Violin); Air (Bach); La Folia (Corelli); True Love (Brahms); Frühling-lied (Kühlmann-Redwitz); In Freud und Leid (Ritter); Melody (Tchaikovsky); Prelude and Allegro (Pignani-Kreisler); Ave Maria (Schlesinger); Frühlingsblüten (Reinecke); Echo (Köhler). 8.0, Talk. 8.30, Records. 8.50, Announcements. 9.0, Hebrew Song Recital by Grussmann. 9.30, Sketch. 9.50, Time Signal; News. 10.10, Songs with Orchestra. 10.40, Dance Records. 11.0 (approx.), Close Down.

BERLIN

DEUTSCHLANDSENDER, 191 kc/s, 1,571 metres; 60 kW.—5.30 a.m., Weather Report for the Gordon Bennett Balloon Race. 5.45, Weather for Farmers. 5.50, News. 6.0, Gym. 6.15, Motto. 6.25, See Leipzig. In the interval at 7.0, News. 8.0, Interval. 8.45, Gym for Women. 9.0, Interval. 10.0, News. 10.10, An Historical Play (Forster) on Records. 10.50, Programme for Children. 11.15, Weather. 11.30, Weather Report for the Gordon Bennett Balloon Race. 11.40, Interval. 11.55, Weather. 12 Noon, See Leipzig. 12.55 p.m., Time. 1.0, Extracts from Aida (Verdi) on Records. 1.45, News. 2.0, Interval. 2.45, Greetings; Programme Announcements. 3.0, Weather; Exchange. 3.15, Talk: Hermann Löns. 3.40, A Discussion: Broadcast Gymnastics for Children. 4.0, See Cologne. 4.50, Weather Report for the Gordon Bennett Balloon Race, 1934. 5.0, See Oslo. 6.5, Records of Swedish Music. 6.20, Topical Talk. 6.50, Result of the National Literary Competition of the 14th September, 1934: Heinrich George reads from one of the Six Books of the Month. 7.20, Songs among the Reeds—A sketch about Music (Jahn). 8.0, Motto; Weather; News. 8.10, See Hamburg. 9.10, Animals Dance—Records. 10.0, News. 10.30, Talk: The Rowing Regatta. 10.45, Weather. 11.0, Weather Report for the Gordon Bennett Balloon Race. 11.10, Records. 12 Midnight (approx.), Close Down.

BERLIN

FUNKSTUNDE, 841 kc/s, 356.7 metres; 100 kW.—6.0 a.m., Hymn; Gym. 6.15, Prayers. 6.20, Orchestral Concert; Conductor, Schönfeldt. In the interval at 7.0, News. 8.0 to 8.20, Gym. 8.30, Announcements; Records. 9.30, Hints for Housewives. 9.45, Programme for Children. 10.0, News. 10.10 to 10.25, Market Prices. 11.25 to 11.30, Exchange. 12 Noon, Concert by the Small Station Orchestra; Conductor, Steiner (Violin); March (Schmidt); Overture, Die Frau Meisterin (Suppe); Serenade (Drdla);

Waltz, Gold and Silver (Lehar); Colombine (Kark); Slav Rhapsody No. 2 (Friedemann); Piece (Bortkiewicz); Barcarolle (Rust); Waltz, Lotoblummen (Ohlson). In the interval at 12.30 p.m., Weather. 1.0, News. 1.15, Opera Records. 2.0, News. 2.15, Viennese Records. 3.0 to 3.20, Exchange. 4.0, See Stuttgart. 5.30, Dance Records. 6.0, Topical Talk. 5.5, Do you know your Ancestors?—A Play for Young People. 6.35, A Black Day for Käberlein—Humorous Scene (Krause). 6.50, Symphonic Studies for Pianoforte Op. 13 (Schumann) by Gisela (Binz). 7.20, Poetry in a Quarry—A Sequence. 7.40, Echoes of the Day. 8.0, News. 8.15, The German Farmer—A Radio Poem (Keienburg) with Music by Wagner-Regeny. 9.5, Concert by the Station Orchestra; Conductor, Frick-hoefler; Soloist, Lore Shepans (Contralto); Idylle (Jos. Marx); Frist Movement from the Goethe Symphony Op. 152 (Reiter); Five Songs for Contralto and Orchestra (Bittner): (a) Es dunkelt, (b) Gesang der Liebenden (c) Das Ständchen, (d) Des Abends, (e) Hymnus; Intermezzo and Carnival Music from Notre Dame (Schmidt). 10.20, News. 10.50, Dance Music from Breslau. 12 Midnight (approx.), Close Down.

BERNE.—Relays Beromünster.

BEROMUNSTER

556 kc/s, 539.6 metres; 60 kW.—12 Noon, Concert by the Station Orchestra; Conductor, Neppach. 1.25 p.m., Time; Weather; Exchange. 3.30, Concert of Popular Opera Music by the Small Station Orchestra; Conductor, Gilbert. 3.59, Time Signal from Neuchâtel Observatory. 4.0, See Sottens. 6.0, Records; Light Music. 6.30, Programme for Young People. 7.0, Time; Weather. 7.1, Labour Exchange. 7.15, Songs and Recitations. 7.40, Concert of Marches; Conductor, Fasolis. 8.5, Report: A Visit to a Porcelain Factory. 9.0, Weather; News. 9.10, Concert of Operetta Music by the Station Orchestra. 9.30, Minna Magdalena—Play (Goetz). 10.0, Concert by the Station Orchestra; Conductor, Gilbert. 10.15 (approx.), Close Down.

BODEN.—Relays Stockholm. BODO.—Relays Oslo.

BRATISLAVA

1,004 kc/s, 298.8 metres; 13.5 kW.—6.0 to 7.15 a.m., See Prague. 9.45, Announcements. 9.50, See Prague. 10.10, News in Hungarian. 10.15, Programme for Hungarian Schools. 10.55, Record. 11.0, Water Level. 11.5, See Prague. 12.10 p.m., Local News in Slovak. 12.15, Record. 12.20, See Prague. 12.30, Concert by the Station Orchestra; Conductor, Schimpl. 1.30, See Prague. 1.40, News and Weather in German and Hungarian. 1.50 to 2.0, See Prague. 3.15, See Brno. 4.15 to 4.20, See Prague. 5.40, Talk: Cycling in Slovakia. 5.50, See Prague. 6.0, Records. 6.10, Talk for Housewives. 6.15, Hungarian Transmission: Victor Egri Programme; Talk and Reading. 6.55, See Prague. 7.10, Talk: Slovakia after 1918. 7.25 to 10.45, See Prague. In the interval at 10.15, See Brno. 10.45, News in Hungarian. 11.0, Close Down.

BREMEN.—Relays Hamburg.

BRESLAU

950 kc/s, 315.8 metres; 60 kW. Relayed by Gleiwitz, 1,231 kc/s, 243.7 metres.—5.0 a.m., Hymn; Motto; Records. In the interval at 5.40, Time; Weather. 6.0, Time; Weather; Gym. 6.25, See Leipzig. In the interval at 7.0, News. 8.0, Opera Records. 9.0, News. 10.10 to 10.40, Stanley Livingstone—A Play for Schools (Tissot). 11.30, News. 11.45, Notes for Farmers. 12 Noon (from Gleiwitz), Orchestral Concert; Conductor, Zielh. March (Blankenburg); Selection from The Barber of Seville (Rossini); Tyrol in Song and Dance (Fetras); Waltz (Ohlson); Selection from Madame Butterfly (Puccini) and Der Obersteiger (Zeller); March (Silwedel); Overture, Leicester (Anber); Waltz (Gungel); Serenade (Heykens); March (Wildehen). In the interval at 12.30 p.m., Notes for Farmers, and at 1.30, News. 2.20, Exchange. 2.25, Announcements; Records; Market Prices. 3.40, Sonatas for Flute and Pianoforte by Knust and Bernert; Sonatas in B minor, G minor and F (Handel); Sonata in A (Frederick the Great). 3.40, A Discussion on Gymnastics. 4.0, Military Band Concert. 5.30, Market Prices. 5.35, Talk for Women. 5.55 (from Gleiwitz), Magazine Review. 6.20, Upper Silesian Folk Songs (arr. Heideuck) by Erich Blisch; Feinslieb verlore; Nachtbesuch; Losgekauft; Wassermanns Braut; Des Grafen Töchterlein; Husarenliebchen; Leise tönt die Abendglocke. 6.50, Announcements; Weather; Market Prices. 7.0, Der goldene Klang—Play (Mühlberger), with Music by Szczuka; Conductor, Rischka. 8.0, To-day's News. 8.10, Community Singing from Fraustadt. 9.10, Recital by the Zilcher Trio and Margret Zilcher-Kiesekamp (Soprano); Trio Sonata in C (Bach-Zilcher); Roccoco Suite for Soprano, Violin and Piano-

TUESDAY
SEPTEMBER THE TWENTY-FIFTH

forte (Zileher); Ten Variations, Op. 121, on the Song Ich bin der Schneider Kakadu (Beethoven). 10.10, Technical Talk. 10.20, News. 10.45, Dance Music by the Station Dance Band; Conductor, Ilmer. 12 Midnight (approx.), Close Down.

BRNO

922 kc/s, 325.4 metres; 82 kW.—6.0 to 7.15 a.m., See Prague. 9.50, See Prague. 10.15, See Moravská-Ostrava. 11.0, See Prague. 12.30 p.m., See Bratislava. 1.30, Talk on Economics. 1.40 to 2.0, See Prague. 3.15, Concert by the Station Orchestra; Conductor, Bakala; March (Cui); Selection from The Snow Maiden (Rimsky-Korsakov); Polonaise from A Life for the Czar (Glinka); Tatra Suite (Smatek); Waltz (Lukieska); March Intermezzo (Bayer). 4.15 to 4.20, See Prague. 5.40, Hints for Housewives. 5.45, Music Report. 5.55, Saxophone Solos by Bystrycky. 6.10, Talk: Finance. 6.20, German Transmission: Social Notes; Programme for Workers; Sports Notes; Talk for Farmers. 6.55, See Prague. 7.10, See Bratislava. 7.25 till Close Down. See Prague. In the interval at 10.15, Schrammel Concert.

BRUSSELS (No. 1)

620 kc/s, 483.9 metres; 15 kW.—11.55 a.m., Weather. 12 Noon, Popular Records. 12.45 p.m., Song Recital by Irma Lievts; Aria from The Creation (Haydn); Elsa's Dream from Lohengrin (Wagner); Chanson triste (Duparc). 1.0, News. 1.10, Extracts from The Cello Concerto (Lalo), by Marie-Jeanne Vaneste. 1.30, Records of Cigány Music. 2.0, Interval. 4.55, News. 5.0, Concert of Dance Music by the Symphony Orchestra. 5.30, Programme for Children. 6.15, Redemption (Frank) on Records. 6.30, Recital by Mme. Pinks-Broadbent (Cello) and Rasette Moldavsky (Pianoforte): Sonata in E minor (Brahms); Part I from the Sonata, Op. 111 (Beethoven); Etude Op. 8, No. 2 (Scriabin); Toccata (Jongen). 7.15, Talk. 7.30, Art Review; Notes for Women. 8.0, Caludi Concert by the Radio Orchestra. 8.45, Double Bass Recital by Bignot: Gavotte from Suite No. 6 (Bach); Legend (Misek); Russian Airs (Nanny). 9.0, Talk: Young People. 9.10, Concert by the Symphony Orchestra; Soloist, Bignot (Double Bass); Variations and Fugue on a Theme of Handel (Delume); Double Bass Concerto (Dragonetti); Double Bass; Perpetuum mobile (Laska); Rhapsody No. 1 (Debussy). 10.0, News. 10.10, Request Records. 10.55, Christus vincit (Liszt). 11.0 (approx.), Close Down.

BRUSSELS (No. 2)

932 kc/s, 321.9 metres; 15 kW.—Programme in Flemish.—11.57 a.m., Weather. 12 Noon, Records. 1.0 p.m., News. 1.10, Overture and Selection from The Merry Wives of Windsor (Nicolaï) on Records. 2.0, Interval. 4.55, News. 5.0, Mozart Concert by the Symphony Orchestra: Overture, Don Giovanni; Symphony in G minor; German Dances. 5.45, Programme for Children. 6.30, Records. 7.0, Talk. 7.15, Records. 7.30, Talk for Housewives. 8.0, Music of the Nations—Concert by the Symphony Orchestra: Overture, Libussa (Smetana); Slav Rhapsody (Dvorák); Symphonic Dance (Grieg); Rhapsody No. 6 (Liszt); Selection from His Life for the Czar (Glinka); Flemish Dance (Block). 8.45, A Sketch. 9.15, Concert by the Radio Orchestra; Soloist, de Booy. 10.0, News. 10.10, Dance Records. 11.0 (approx.), Close Down.

BUCHAREST

823 kc/s, 364.5 metres; 12 kW.—12 Noon, Water Level; Records. 12.45 p.m., Amusement Guide; Exchange; Records of Light Music. 1.15, Time; Weather; News. 1.40, Records of Light Music. 5.0, Concert by the Gica Ionescu Orchestra; Soloist, Gica Ionescu (Pianoforte); Johann Strauss Potpourri; National Song Potpourri; Serenade (Schubert); Two Pieces (Mauritti); Vers ta fenetre (Moretti); Tango (Ionescu); Selection from Lilac Time (Schubert-Berte); Russian Song; Pianoforte Solo; Potpourri of Romanian Melodies. 6.0, Time; Weather; News. 6.15, Concert by the Gica Ionescu Orchestra; Two Preludes. (Chopin); Concert Waltz (Moskovsky); Tango (Andreescu); Tango (Bosnicanu); Caroca (Younans); Popular Romanian Songs. 7.0, Educational Programme. 7.15, Records. 7.45, Talk. 8.0, Beethoven Symphony Concert by the Station Orchestra; Conductor, Ionel Perlea; Soloist, Herez (Pianoforte); Symphony No. 1 in C; Pianoforte Concerto in E flat; Symphony No. 5 in F. In the interval at 9.0, Talk. 10.0, News.

BUDAPEST

546 kc/s, 549.5 metres; 120 kW.—6.45 a.m., Gym. 9.45, News. 10.0, Talks. 12 Noon, Chimes. 12.5 p.m., Concert by the Budapest Chamber Orchestra. 1.30, Concert by the

Rázcz Cigány Band. 2.40, Market Prices; Cookery Notes. 4.0, Programme for Women. 5.0, Talk. 5.35, Song Recital by Dora Bárony. 6.15, French Lesson. 7.30, Talk. 8.5, Records. 8.40, Recital by Piroksa Vaszary and György Kürthy. 9.50, String Quartet Concert.

CASSEL.—Relays Frankfurt.

COLOGNE

658 kc/s, 455.9 metres; 60 kW.—5.50 a.m., Hymn; Records. 6.5, Gym. 6.25, See Leipzig. In the interval at 6.50, News. 8.0, Time; Weather. 8.5 to 8.20, Gym for Women. 10.0, News. 10.10, Gym for Children. 10.30, Records. 11.0, Talk with Records: The East. 11.30, Announcements; Records. 12 Noon, Concert by the Station Schrammel Quartet; Soloist, Schneider (Baritone). 12.45 p.m., Announcements; Greetings. 1.0 to 2.45, Concert by the Station Chamber Orchestra; Conductor, Hartmann; Overture, Der Wildschütz (Lortzing); Lagunen-Walzer (Strauss); Selection from The Barber of Seville (Rossini); Forest Murmurs (Czibulka); Norwegian Rhapsody (Svendsen); Waltz, Toupjours on j'amain (Waldteufel); Pikante Blätter (Komzak); Two Pieces (Abl): (a) O Jugend, wie bist du so schön, (b) Gute Nacht, du mein herziges Kind; Ein Morgen in Sanssouci (Koekert). In the interval at 1.45, Announcements. 3.10, A Discussion on the New Trade Laws. 3.30, Exchange. 3.45, Book Review for Women. 4.0, Concert by the Small Station Orchestra; Conductor, Eysoldt; Soloist, Kreisel (Saxophone); Spitzweg-Folge (Niemann-Spiess); Two Pieces (Grieg-Mauss): (a) Liebe, (b) Die alte Mutter; Blauso Stunde (Beste); Extracts from Karneval (Bohm-v. d. Berg); Two Pieces (Zeh); (a) Heimweh, (b) Liebesständchen; Saxophone Solo (Beste); Three Pieces (Jensen-Mauss): (a) Kassandra, (b) Die Zauberin, (c) Eros (from Erotikon). 5.0, A Visit to the Folkwang Museum, Essen. 5.30, Three Ballads (Loewe). 5.45, Talk: Widukind. 6.0, A Play for Young People. 6.20, Talk: Electricity. 6.40, Topical Talk. 6.50, Exchange; Sports Notes. 7.0, Concert by a Wind Instrument Orchestra; Conductor, Kühn. 7.45, Report from the Essen Exhibition. 8.0, News. 8.10, Concert by the Station Chamber Quintet. 8.45, The Poor Broom-makers—Play (Carl Hauptmann), with Music (Zillig). 10.0, News. 10.20, Chess Lesson. 10.30 (approx.), Close Down.

COPENHAGEN.—Relays Kalundborg. CORK.—Relays Athlone. DANZIG.—Relays Königsberg. DRESDEN.—Relays Leipzig.

FECAMP

1,456 kc/s, 206 metres; 10 kW.—11.30 a.m. to 12 Noon, Programme in English arranged by the International Broadcasting Company of London. 11.30, Happy Half-Hour; Dance Music. 12 Noon, Programme in French. 4.30 to 6.0 p.m., Programme in English arranged by the I.B.C. (London). 4.30, Torquay. Exeter, Plymouth and Devonport Concert; Part I: Yodelling Holland. 5.0, Part II: Dance Music. 5.30, Part III: Orchestral Music. 6.0, Programme in French. 11.0 till Close Down, Programme in English arranged by the I.B.C. (London). 11.0, Request Programme compiled by the Saints Rhythm Club. 11.30, Concert arranged by the I.B.C. (Ireland), Ltd.: Light Music. 12.30 a.m. (Wednesday), I.B.C. Time Signal. 12.31, Dance Music. 1.0, I.B.C. Goodnight Melody and Close Down.

FLENSBURG.—Relays Hamburg. FLORINCE.—Relays Milan.

FRANKFURT

1,195 kc/s, 251 metres; 17 kW.—5.45 a.m., Hymn; Time; Weather. 5.50, Gym. 6.40, Time; Announcements. 6.50, Weather. 6.55, Concert from Stuttgart. 8.10, Water Level; Weather. 8.15 to 8.35, Gym. 10.0, News. 10.45, Cookery Hints. 11.0, Announcements; Records. 11.30, Announcements; Exchange; Weather. 11.45, Social Notes. 12 Noon, Records. 1.0 p.m., Time; Local News. 1.20, Orchestral Concert. In the interval at 1.50, News. 2.30, Industrial Review. 2.45, Time; Exchange. 2.55, Weather. 3.0, News. 3.10, Programme for Women. 3.30, Talk. 3.50, Art Notes. 4.0, Concert by the Station Orchestra; Conductor, Belker; Soloist, Herta-Irene Müller-Gärtner (Mezzo-soprano) and Kullmann (Pianoforte); Part I—Light Music; Dance Suite from Le roi s'amuse (Delibes); Two Pieces from An Indian Fairy Story (Förster); Ballet Suite from Hiawatha (Coleridge-Taylor); Part II—Paul Graener; Lieder for Mezzo-soprano; Part III—Old Dance Music. 5.30, Talk. 5.45, Hunting Songs by Peter Schäfer (Bass). 6.0, Technical Talk. 6.15, Industrial Reports. 6.25, Italian Lesson. 6.45, Weather; Exchange; Announcements; Time. 6.50, Light Orchestral Concert from Freiburg. 7.45, Topical Talk; 8.0, Time; News. 8.10, Little Know Selumann; Lieder by Willy (Baritone). 8.40, Gehlhansen—Sequence (Paul Laven). 9.10, Concert by the Station Orchestra; Conductor, Belker; Gallop (Eilenberg); Waltz from La Poupee (Andran); Polka (Bayer); Selection from Ten Maids and no Man (Suppe); Waltz. Das Leben ist doch schön (Ed. Strauss); Polka-Mazurka from Die Jagd nach dem Glück (Suppe); Waltz (Vollstedt); Polka (Joh. Strauss). 10.20, Time; News. 10.35, Topical Talk. 10.45, News. 11.0, See Stuttgart.

SEPT. 25th TUESDAY continued

12 Midnight, Jean Sibelius Records. 1.0 a.m. (Wednesday), Close Down.

FREDRIKSSTAD.—Relays Oslo. FRIEBURG.—Relays Stuttgart. GENEVA.—Relays Sottens. GENOA.—Relays Milan. GLEIWITZ.—Relays Breslau. GOTEBORG.—Relays Stockholm. GRAZ.—Relays Vienna. HAMAR.—Relays Oslo.

HAMBURG

904 kc/s, 331.9 metres; 100 kW. Relayed by Bremen, Flensburg and Hanover, 1,330 kc/s, 225.6 metres.—5.45 a.m., Time; Weather; Notes for Farmers. 6.0, Gym, 6.15, Time; Weather. 6.20, See Berlin (Funkstunde). In the interval at 7.0, Time; News. 8.0, Weather; Talk for Housewives. 8.10, Announcements; Records. 10.50, News. 11.0, Harvest Festival Music for Schools. 11.45, Records. 12 Noon, Hints for Housewives. 12.5 p.m., Time; Weather; Shipping Notes. 12.15, Concert from Berlin (Funkstunde). 1.0, Exchange. 1.15, Weather. 1.20, Light Music. 2.15, News. 2.30, Records. 3.0, Exchange. 3.40, Shipping and Aviation Notes. 4.0, See Stuttgart. 5.30, Talk for Women. 6.10, Topical Talks. 6.45, Exchange. 6.55, Weather. 7.0, Programme for Young People (on Records). 8.0, News. 8.10, Johann Strauss—Literary and Musical Sequence (Scheffer). The Station Orchestra and Soloists. Conductor: Eibenschütz. 9.10, See Stuttgart. 10.0, News. 10.20, Light Music. 11.0, Orchestra Concert from Kiel. Conductor, Döring. Schweizer Schützengilde (Zimmer); Bergweiser (Clemus); Kirchweih in Tirol (Krome); Erinnerung an Luzern (Blon); Fantasia on Swiss Songs (Leopold); The Secrets of the Adige (Carena); Edelweiss (Lange); Tyroler March (Dreyer). 12 Midnight (approx.), Close Down.

HANOVER.—Relays Hamburg.

HILVERSUM

160 kc/s, 1,875 metres; 7 kW. (until 3.40 p.m.). Transmitted on Kootwijk, 60 kW., from 3.40 p.m.—7.40 a.m. to 5.10 p.m., Programme of the General Broadcasting Society (A.V.R.O.). 7.40 a.m., Time. 7.41, Records. 8.40, Concert by the Rentmeester Orchestra. 9.40, Time. 9.41, Service. 10.10, Concert by the Rentmeester Orchestra. 10.40, Cookery Talk. 11.10, Records. 11.40, Time. 11.41, Concert of Light Music by the Minstrels. In the interval, Records. 1.55 p.m., Records. 2.10, Cello and Pianoforte Recital by Bram van Zanten and Egbert Veen. 2.40, Talk for Women. 2.50, Records. 3.40, Interval. 3.55, Records. 4.10, Concert by a Children's Choir. Conductor: Hamel. 4.40, Programme for Children. 5.10, Talk arranged by the Liberal Protestant Radio Society (V.P.R.O.). 5.40 till Close Down. A.V.R.O. Programme. 5.40, Concert by the A.V.R.O. Orchestra. Conductor: Gerharz. Jugend Heraus (Teike); Hungarian Comedy Overture (Keler-Béla); Piece (Vollstedt); Johann Strauss Potpourri (Schlögel). 6.10, Talk by the R.V.U. 6.40, Concert by the A.V.R.O. Orchestra. Conductor: Gerharz. Soloist: Judith Toft (Soprano). Overture, Iphigenia in Aulis (Gluck); Two Songs (Gluck); Prelude to Le Déjeuner (Saint-Saëns); Songs: (a) La cloche (Saint-Saëns), (b) Aria from Samson and Delilah (Saint-Saëns); Potpourri (Charpentier). 7.40, Time. 7.41, News. 7.45, Talk: The English Lessons. 7.55, Concert by the A.V.R.O. Orchestra. Conductor: Gerharz. Soloist: Egbert Veen (Pianoforte): Pianoforte Concerto (Dittersdorf); Four Waltzes (Brahms). 8.20, Recitation. 8.40, Variety Programme. Kovacs Lajos and his Orchestra. The Paradise Garden Hawaiians, Pierre Palla (Organ), and Boris Lenskij (Violin). 10.40, Records. 11.40 (approx.), Close Down.

HORBY.—Relays Stockholm.

HUIZEN

995 kc/s, 301.5 metres; 7 kW. (until 6.40 p.m.); 20 kW. from 6.40 p.m. Programme of the Catholic Radio Society (K.R.O.).—7.40 a.m., Records. 8.55, Interval. 9.25, Pontifical High Mass from Utrecht. 11.25, Records. 11.40, Police Messages. 11.55, Records. 12.40 p.m., Concert by the K.R.O. Boys. 1.25, Interval. 1.40, Programme for Women. 2.40, Records. 3.10, Concert. Mile. Eline Hemricka (Soprano). Tromp (Viola). and Boshart (Pianoforte). Soprano Solos: (a) Aria from Der Schauspieler (Mozart), (b) Aria from La Traviata (Mozart), (c) Ständchen (Strauss), (d) Waldeinsamkeit (Reger); Violin Solos: (a) Le Déjeuner (Saint-Saëns), (b) Minuet (Paderewsky-Kreisler), (c) Polchielletto (Kreisler), (d) Hungarian Dance, No. 3 (Brahms), (e) Mummenschanz (Korngold); Records; Soprano Solos: (a) Aria from Faust (Gounod), (b) Ich ging mit Lust durch einen grünen Wald (Mahler), (c) De nachtegaal (Zagwin); Violin Solos: (a) Romance (Wieniawski), (b) Suite (Röntgen). 4.40, Records. 4.55, Light Music by the K.R.O. Boys. 5.40, Talk. 6.0, Light Music by the K.R.O. Boys. 6.40, Police Messages. 6.55, Talk. 7.15, Records. 7.30, Talk. 7.40, Concert by the K.R.O. Orchestra. Conductor: Gerritsen. Rakoczy Overture (Kéler-Béla); Dream Children (Elgar); Selection from Madame Butterfly (Puccini); Symphony No. 1 in C (Beethoven). In the interval at 8.10, News and Talk. 9.0, Recitation. 9.10, Concert by Travin and his Russian Ensemble. 9.40, Concert by the K.R.O. Orchestra: Two Nocturnes (Debussy); Suite, Mother Goose (Ravel); Selection from The Czarevitch (Léhar). In the interval at 10.10, News and Recitation. 10.40, Concert by Travin and his Russian

Ensemble. 11.10, Records. 11.40 (approx.), Close Down.

INNSBRUCK.—Relays Vienna.

KALUNDBORG

238 kc/s, 1,261 metres; 75 kW. Relayed by Copenhagen, 1,176 kc/s, 255.1 metres; and Skamlebaek, 49.5 metres.—7.0 a.m., Gym. 8.30, Service from Copenhagen Cathedral. 10.15 to 10.45, Hygiene Talk for Schools. 11.0, Weather. 11.10, Fish Prices. 12 Noon, Chimes. 12.2 p.m., Concert by Nielsen's String Ensemble, relayed from the Ritz. 2.0, Interval. 3.0, Concert by the Radio Orchestra; Conductor, Mahler; Soloist, Peder Jacobsen (Songs): Overture, La rencontre imprévue (Gluck); Divertimento, Il combattimento dell'umane passioni (v. Dittersdorf); Minuet (Schubert); March from Indigo (Strauss); Waltz, Aquarellen (Jos. Strauss); Overture, Gasparone (Müllbacher); Songs of the Forest; Overture, Costi fan tutte (Mozart); March in D (Mozart); Waltz from Donna Diana (Reznicek); March from The Mikado (Sullivan); Ballet Music from Ali Baba (Lecocq); Overture, La belle Héloéne (Offenbach). 5.0, See Oslo. 5.30, Exchange; Poem. 5.45, Talk: André Gide. 6.15, German Lesson. 6.45, Weather. 6.54, Wireless Notes. 7.0, News. 7.15, Time. 7.20, Talk: Children's Day. 7.30, Talk: Present Day Economics. 8.0, Chimes. 8.2, Mouth Organ Recital. 8.15, Verdi Records. 8.30, Le Retour de l'Enfant prodige—Play (André Gide); Translation by Jørgen Budtz-Jørgensen. 9.15, Concert of French Music by the Radio Orchestra; Conductor, Emil Reesen: Overture, Les petits Savoyards (Dalavrac); Ballet Music from Naila (Delibes); Overture, The Black Domino (Auber); Dance from Le roi l'a dit (Delibes); Suite from Izeul (Pierne); Rigaudon from Le tombeau de Couperin (Ravel). 10.10, News. 10.25, Grand Duo in C, Op. 110 (Schubert), by Folmer Jensen and Ove Peters. 11.0, Dance Music by Johansen's Band, relayed from the Lodberg. In the interval at 12 Midnight, Chimes. 12.30 a.m. (Wednesday), Close Down.

KIEL.—Relays Hamburg. KLAGENFURT.—Relays Vienna.

KONIGSBERG

1,031 kc/s, 291 metres; 60 kW. Relayed by Danzig, 1,303 kc/s, 230.2 metres.—5.0 a.m., Records. 5.50, Weather. 6.0, Gym. 6.20, Concert from Berlin (Funkstunde). In the interval at 7.0, News. 8.0, Prayers. 8.30, Gym for Women. 9.0, Interval. 10.40, News. 10.55, Weather. 11.5, Talk: The German Peasantry. 11.30 (from Danzig), Records. 12 Noon, See Berlin (Funkstunde). In the interval at 12.30 p.m., News. 1.1, Time; Weather. 1.5, Scandinavian Records. In the intervals at 1.20 and 2.0, News. 2.30, Announcements; Records. 3.0, Market Prices. 3.10, Book Review. 3.25, Recital by Honka von Ferenczy (Songs). 3.50, Fashion Notes. 4.0, Concert by the Small Station Orchestra. Conductor: Wilcken. Fantastic March (Wilcken); Overture, Turandot (Lachner); Nordic Lyric Suite (Palmgren); Selection from Ernani (Verdi); Intermezzo (Schmalstieg); Minuet (Richter); Russian Rhapsody (Heusser); Overture, Giralda (Adam). 5.20, Talk: The History of the Town of Calico. 5.45, Pianoforte Quintet in F minor (Frank). 6.15, Market Prices. 6.25, Talk by Vice-President Rhode: Handwork and National-Socialist Policy. Political Education. 6.55, Weather. 7.0 (from Danzig), Programme for Young People. 7.30, Mandoline and Guitar Music. Conductor: Lenzing. Overture in D minor (Köhler); Minuet (Grazianni-Walter); Spanish Waltz (Mann); Am Spinnradchen (Ritter); Ländler (Althoff); March (Blankenburg-Mandt). 8.0, Weather; News. 8.10, East Prussia in August, 1914—Radio Scenes. 9.30, Records. 9.45, Report of the Parade of Stallions in Georgensburg. 10.0, News. 10.30, Dance Music and Light Music by the Small Station Orchestra and Börschel's Dance Band. 12 Midnight (approx.), Close Down.

KOSICE.—Relays Prague. LAUSANNE.—Relays Sottens.

LEIPZIG

785 kc/s, 382.2 metres; 120 kW. Relayed by Dresden, 1,285 kc/s, 233.5 metres.—5.50 a.m., Notes for Farmers. 6.0, Gym. 6.25, Orchestral Concert from Dessau. In the interval at 7.0, News. 8.0, Gym. 8.20, Records. 9.0 to 9.20, Programme for Women. 9.40, Exchange. 9.45, News. 10.10 to 10.50, A Sequence for Schools; Count Zeppelin. 11.0, Announcements; Records. 11.30, News; Time. 11.40, Weather. 11.45, Notes for Farmers. 12 Noon (from Dresden), Concert by the Dresden Philharmonic Orchestra. Conductor: Schestak. Overture, Turandot (Lachner); Tanzmoments (Herbeck); Selection from Manon (Massenet); Waltz, Am Neckarstrand (Müllbacher); Overture, Tancered (Rossini); Aquarellen (Gade); Serenade No. 3 for Strings (Volkmann); Slav Dances Nos. 1 and 3 (Dvorák); Overture, Isabella (Suppé). In the interval at 1.0 p.m., News; Time. 2.0 to 2.15, News; Exchange; Weather. 3.0,

Julius Kleugel Cello Records. 3.15, Programme for the Hitler Youth. 3.35, Exchange. 4.0, See Munich. 4.40, Talk by Albert Schweitzer: Old Legal Forms in Modern Speech. 5.0, See Oslo. 6.0, Exchange; Weather; Time. 6.10, Talk: Germany and Greece. 6.30, Concert by the Station Orchestra. Conductor: Blumer. Soloist: Kindscher (Violin). Overture, Indigo (Jos. Strauss); Ballade and Polonaise for Violin and Orchestra (Vieuxtemps); Dance of the Niads, and Fantastic Rondo from the Suite, Hersilia (d'Ambrosio); Two Pieces for Pianoforte (Schütt): (a) A la bien-aimée, (b) Réverie; Three Pieces (Nicodé): (a) Bolero, (b) Moorish Dance Song, (c) Serenade; Waltz (Ed. Strauss); Piedmontese Dance No. 1 (Sinigaglia). 7.35, Talk: Marshal Radetzky. 7.55, Announcements. 8.0, News. 8.10, Casanova—Opera in Three Acts (Lortzing), by the Leipzig Symphony Orchestra and Soloists. Conductor: Weber. 10.20, News. 10.50, Dance Music from Breslau. 12 Midnight (approx.), Close Down.

LINZ.—Relays Vienna.

LJUBLJANA

527 kc/s, 569.3 metres; 5 kW.—12.15 p.m., Records. 12.50, News. 1.0, Weather; Records. 6.0, Talk. 6.20, Records for Children. 7.0, Programme for Children. 7.30, Talk. 7.50, Weather; Cookery Hints. 8.0, Programme for Sokols. 8.20, Songs and Mandoline Quartet Music. 9.20, Concert by the Station Orchestra. 10.10, Weather; News. 10.30 to 11.0, Programme in English arranged by the International Broadcasting Company of London; Concert of Light Music.

LUXEMBOURG

230 kc/s, 1,304 metres, 150 kW.—7.45 a.m., Records. 8.0, News in French; Record; News in German; Record. 12 Noon, Concert by the Station Orchestra; Conductor, Pensis: March (Goldmark); Montanina (Pumo); Symphonic Poem, Finlandia (Sibelius); Selection from Electra (R. Strauss); Piece (Silesu). 12.30 p.m., News in French and German. 12.40, Concert (contd.): Promenade matinale and Anbade (Pierne); Suite, Le Printemps (Nevin); Tango (Demaret); Selection from Hit the Deck (Youmans-Salabert); March (Morena); in the interval at 1.0, Exchange. 1.15, Record. 1.30, Exchange. 1.35, Records. 2.0, Exchange. 3.45, Exchange. 6.30, Concert of Light Music and Dance Music. 7.30, Racing Results. 7.35 till Close Down, Belgian Evening. 7.35, Talk: Luxembourg as a Tourist Country. 7.40, Records. 8.0, News in French and German. 8.20, Pianoforte Recital by Zakin. 8.35, Exchange. 8.40, Concert of Belgian Music by the Station Orchestra: Prelude (Rogister); Belgian Military Waltz (Fréméaux); Suite pastorale (Vreuls); Chanson de Mai (Dupuis); Sur le Rocher (Gachet); Berceuse (Leemans); Week-End Suite (Caldui); Berceuse (Soiron); Piece (Wallet); Badinage (Jongen-Mouton). 9.30, Pianoforte Recital by Berthe Bernard. 10.0, Concert by the Station Trio; March (Kreisler); Serenade (Glschlegel); Barcarolle (de Taeye); Nina (Pergolèse-Kreisler); Berceuse de Jocelyn (Godard); Piece (Fancelli); Syncopation (Kreisler). 10.30, Dance Music by the Station Jazz Band; Conductor, Jouza.

MADRID

EAJ7, 1,095 kc/s, 274 metres; 7 kW.—9.0 a.m., News. 10.0, Announcements; Exchange; Weather. 10.30, Interval. 2.0 p.m., Chimes; Time; Weather; Popular Music; Talk. 2.30, Sextet Concert of Mozart Music. 3.07 Amusement Guide; Exchange; Popular Music. 3.30, Sextet Concert of Schubert Music. 4.0, News; Popular Music. 4.30, Sextet Concert of Beethoven and Wagner Music. 4.50, Film Review; News. 5.0, Interval. 6.0, Chimes; Light Music. 7.0, Announcements; Hygiene Talk. 7.30, Exchange; Military Band Concert. 8.0, News; Pianoforte Recital. 8.30, Hunting and Fishing Notes. 8.45, Concert. Part I, Operetta Music. Part II, Opera Music. 9.40, Sports Notes. 10.0, Chimes; Time; History Talk by Ramón Gómez de la Serna. 10.30, Song Recital by Carmen Girolami (Mezzosoprano). 11.0, News; Sextet Concert. 11.30, Programme relayed from a Theatre. 12.45 a.m. (Wednesday), News; Time. 1.0, Chimes. 2.0 till Close Down, Programme in English, arranged by the International Broadcasting Company of London: Dance Music. 3.0, I.B.C. Good-night Melody and Close Down.

MILAN

814 kc/s, 368.6 metres; 50 kW. Relayed by Turin, 1,140 kc/s, 263.2 metres; Genoa, 986 kc/s, 304.3 metres; and Florence, 610 kc/s, 491.8 metres.—7.30 a.m., Gym. 7.45, Time; News. 8.0, Interval. 1.30, Operetta Records. 12.30 p.m., Records. 12.45, News. 1.0, News. 1.5, Concert by the Malatesta Chamber Orchestra. In the interval at 1.30, Records; Exchange. 2.15 to 2.25, Exchange. 4.35, News. 4.45, Programme for Children. 5.10, Concert by the Doreno Orchestra. 5.55,

Weather. 6.0 to 6.10, Notes for Farmers; Corn Prices. 7.0, Announcements. 7.15, News in Foreign Languages. 8.0, Time; News; Records. 8.30, Government Notes. 8.45, Donna Juanita—Operetta in Three Acts (Suppé); Conductor, Fabbri. In the interval: Talk; Art Notes. 11.0 (approx.), News.

MONTE CENERI

1,167 kc/s, 257.1 metres; 15 kW.—12 Noon, News. 12.5 p.m., Light Music by the Radio Orchestra; Russian March (Ohlsen); Waltz (Strauss); Overture, La battaglia di Legnano (Verdi); Nocturne (Derksen). 12.29 p.m., Time; Weather. 12.33, Concert (contd.): Selection from Hérodiade (Massenet); Piece (Deshayes); Dance (Friml). 12.55, News. 1.5 to 1.30, Records. 3.59, Time. 4.0 to 6.0, See Sottens. 7.45, News. 8.0, Concert of Fantasias and Symphonic Pieces. 8.45, Italian Opera Arias. 9.0, Popular Songs. 9.30, Dance Music. 10.0, Close Down.

MORAVSKA-OSTRAVA

1,158 kc/s, 259.1 metres; 11.2 kW.—6.0 to 7.15 a.m., See Prague. 9.50, See Prague. 10.15, Concert by the Station Orchestra; Conductor, Divis. 11.0, See Prague. 12.30 p.m., See Bratislava. 1.30 to 2.0, See Prague. 3.15, See Brno. 4.15 to 4.20, See Prague. 5.40, Talk: The Great War. 5.50, Records. 5.55, News. 6.0, Talk: How to Learn Foreign Languages. 6.10, Reading. 6.20, See Brno. 6.55, See Prague. 7.10, See Bratislava. 7.25 to 10.45, See Prague. In the interval at 10.15, See Brno. 10.45, Talk in Esperanto: Estonia. 11.0 (approx.), Close Down.

MOSCOW (No. 1)

174 kc/s, 1,724 metres; 500 kW.—5.0 a.m., News. 5.15, Fanfare. 5.45, Gym. 6.15, Musical Programme. 8.15, Programme for Children. 9.0, Musical Programme. 9.58, Time. 10.0, News. 10.15, Concert for Collectivist Farmers. 3.0 p.m., Programme Announcements. 3.15, Programme for Children. 3.30, Communist Party Programme. 4.0, News. 5.30, Red Army Programme. 6.30, Reading for Collectivist Farmers. 8.0, Orchestral and Choral Concert. 9.0, Technical Talk in German. 9.55, Chimes. 10.5, Talk in French; Soviet Law. 11.5, Talk in Dutch; Soviet Law.

MOTALA.—Relays Stockholm. MUM-LACKER.—See Stuttgart.

MUNICH

740 kc/s, 405.4 metres; 100 kW. Relayed by Augsburg and Nürnberg, 1,267 kc/s, 236.8 metres.—6.30 a.m., Gym. 6.45, Molto; Records. 7.15, Time; Weather; News. 7.25, Concert from Stuttgart. 9.50, Cookery Hints. 10.10, French for Schools. 10.55, Market Prices. 11.5, Notes for Farmers. 11.15, News. 11.30, Announcements; Records. 12 Noon, Concert by the Station Orchestra; Conductor, List: Overture, The Merry Wives of Windsor (Nicolaï); In the Steppes of Central Asia (Borodin); Waltz Fantasia (Glinka); Hungarian Rhapsody No. 2 (Liszt); Scherzo (MacDowell); Valse triste (Sibelius); Polonaise from Eugene Onegin (Tchaikovsky). 1.15, News. 1.25, Soloist Records. 2.0, News; Announcements; Exchange. 2.20, Recital by Grauert (Bartone), Hoffmann (Violin) and Maria Fahmüller (Clavier): Toccata and Fugue in D for Pianoforte (Bach); Aria for Baritone and Pianoforte from Julius César for Clavier and Baritone (Handel); Two Old Italian Pieces for Violin and Clavier: (a) Tempo di minuetto (Pugnani), (b) Largo and Allegro commodo (Tartini). 2.50, Talk for Women. 3.30, Talk. 3.50, Weather; Notes for Farmers. 4.0, Concert by the Small Station Orchestra; Conductor, Kloss: Overture, Die Fledermaus (Joh. Strauss); Intermezzo from Suor Angelica (Puccini); Extracts from Arabella (R. Strauss); Pesther-Walzer (Lanner); Extracts from Liselott (Künneke); Chinese Sketches and Oriental Scene (Leemans); Dance of the Merry Mascots (Ketelbey); Two Pieces (Schütt): (a) Styria Waltz, (b) A la Gavotte. 5.30, Talk: Reclaiming Land from the North Sea. 5.50, The Wanderer Fantasia (Schubert) by Pillemy (Pianoforte). 6.10, Talk by a University Student: Life in a Students' Hotel. 6.30, Song Records. 6.50, Time; Weather; Notes for Farmers. 7.0, Concert by the Station Orchestra; Conductor; List. 8.0, News. 8.15, D'Schultheis-senwahl—A Swabian Comedy of the Rococo Period (Weichenmayr). 9.35, With the Microphone to Alt Lindau, Lake Constance. 10.0, Time; Weather; News; Exchange; Sports Notes. 10.20, Programme to be announced. 11.0, Concert from Lindau, Lake Constance. 12 Midnight (approx.), Close Down.

NAPLES.—Relays Rome. NOTODDEN.—Relays Oslo.

OSLO

260 kc/s, 1,154 metres; 60 kW. Relayed by Hamar, 519 kc/s, 578 metres; and Jelling, 6,980 kc/s, 42.92 metres.—11.45 a.m., Service. 11.50, Exchange. 12.55 p.m., Nauen Time Signal. 1.0 to 2.0, Records. In the interval at 1.15, Weather; Talk for Farmers, and at 1.45, Exchange. 4.40, Talk. 5.0, The Seventh Scandinavian Music Festival—Norwegian and Swedish Chamber Music. Soloists, Julia Clausen, Krogh and Rigmor Nordbye (Songs), Halvorsen (Violin), Berit Cleve (Pianoforte): Serenade for String Quartet

SEPT. 25th **TUESDAY** continued

PARIS

ECOLE SUPERIEURE, 695 kc/s, 431.7 metres; 7 kW.—12 Noon, Tourist Report. 12.15 p.m., Concert relayed from Toulouse, P.T.T., 776 kc/s, 386.6 metres. In the interval at 1.0, News. 2.0, Records: Sonatas and Light Music. 4.0, See **Pontoise (Radio-Colonial)**. 6.0, Dramatic Programme. 6.30, News. 7.45, Science Talk. 7.50, Relay from the Opéra-Comique: Tosca—Opera in Three Acts (Puccini); Cavalleria Rusticana—Opera in Two Acts (Mascagni).

PARIS

POSTE PARISIEN, 959 kc/s, 312.8 metres; 100 kW.—7.10 a.m., Fanfare; Records. In the intervals at 7.30 and 8.20, News. 8.45, Cookery Talk. 12 Noon, Exchange. 12.5 p.m., Records. 12.25, News. 12.35, New Records. 1.5, Exchange. 1.15, Records. In the interval at 1.30, Exchange. 2.0, Exchange. 3.15, Exchange. 3.45, Exchange. 4.50, Exchange. 6.45, Exchange. 6.49, Records. 7.10, News. 7.30, Records: Le Carnaval des Animaux (Saint-Saëns), 8.0, Interval. 8.10, Concert by the Paris Saxophone Quartet: Allegro vivace (Raff); Scherzo (Schubert); Minuet (Beethoven); Scherzo (Schumann); Cordoba (Albéniz); Moment musical (Schubert); Presto (Mendelssohn), 8.40, Exchange. 8.50, The Trout Quintet (Schubert), 9.30, Interval. 9.40, Dance Music. 10.20, News. 10.30 till Close Down. Programme in English arranged by the International Broadcasting Company of London. 10.30, Light Music. 11.0, I.B.C. Goodnight Melody and Close Down.

PARIS

RADIO PARIS, 182 kc/s, 1,648 metres; 75 kW.—6.45 a.m., Gym. 7.0, Records. 7.15, Press Review; Weather. 7.45, Gym. 8.0, Records. 12 Noon, Symphony Concert; Conductor, André; Soloist, Janine Carlyse (Soprano); Neapolitan March (Costa); Waltz Suite, España (Chabrier-Waldteufel); Overture, La Fête au Village Voisin (Boieldieu); Two Songs; Chanson intime (de la Presle); Extract from Mignon (Thomas); Songs; Devant la Madone (Massenet); Selection from The Pearl Fishers (Bizet); Two Songs; Minuet (Paradis); Potpourri (Cléric); Songs; Destiny (Baynes); Selection from The Desert Song (Romberg); Malaguena (Albéniz); Tango (Albéniz); The Mosquitos' Parade (Whitney). In the interval at 1.20, Exchange. 3.45, Exchange. 6.20, Weather; Notes for Farmers; Exchange; Racing Results. 6.45, Records. 7.0, Talk: The Russian Theatre. 7.30, Topical Talk. 8.0, L'Épervier—Play (de Croisset). In the interval at 8.30, Press Review; Weather; and at 9.15, News. 10.30, Dance Music by Victor Pascal's Orchestra.

PITTSBURGH

KDKA, 980 kc/s, 306 metres; 50 kW. Relayed by **WXXK**, on 48.86 metres; and 25.27 metres.—3.0 p.m., Edward MacLough. 3.15, Castles of Romance. 3.30, To-day's Children. 3.45, News; Cookery Hints. 4.0, Honey-mooners. 4.15, Tony Wons. 4.30, Melody Mixers. 5.0, Fields and Hall. 5.15, Merry Maes. 5.30, Vic and Sade. 5.45, Hotel William Penn Orchestra. 6.0, Exchange. 6.15, Honourable Archie and Frank. 6.30, Farm and Home Tour. 7.30, KDKA Home Forum. 8.0, Sammy Fuller. 8.15, Congress of Clubs. 8.30, Joseph Gallicchio and his Orchestra. 9.0, Betty and Bob. 9.15, Singing Stranger. 9.30, Exchange. 9.45, Chicago Symphony Orchestra. 10.15, KDKA Kiddies' Klub. 10.30, The Singing Lady. 10.45, Orphan Annie. 11.0, Dan and Sylvia. 11.14, Baseball Resume. 11.30, News; Musical Programme. 11.45, Lowell Thomas. 12 Midnight, Amos 'n' Andy. 12.15 a.m. (Wednesday), Programme to be announced. 12.30, Household Musical Memories. 1.0 to 6.0, Popular Programme.

PONTOISE

RADIO-COLONIAL, 15,244 kc/s, 19.68 metres; 15 kW. (1.30 to 5.0 p.m.); 11,905 kc/s, 25.20 metres (5.15 to 12 Midnight), and 11,705 kc/s, 25.63 metres (12.15 a.m. Monday to 6.0).—4.0 to 5.0 p.m., Concert by the Station Orchestra; Conductor, Benvenuti; The Unfinished Symphony (Schubert); Pavane (Fauré); Ballet Music from Le Cid (Massenet); Selection from The Love Parade (Schertzinger). 6.30 to 7.30, Quintet Concert: Overture, Fingal's Cave (Mendelssohn); Selection from Don Quichotte (Massenet); Images (Ibert); Selection from La Vivandière (Godard); Selection from Le bourgeois Gentilhomme (Lully); Selection from Gipsy Love (Lehnér); Selection from Conte Obligado (Moretto). 7.50, See **Paris (Ecole Supérieure)**. 5.0 to 6.0 a.m. (Wednesday), Recital by Mme. Fascholin (Violin), Caurat (Tenor), and Petit (Pianoforte).

PORSGRUND.—Relays Oslo.

PRAGUE

638 kc/s, 470.2 metres; 120 kW.—6.0 a.m., Gym; Music; News. 7.15, Interval. 9.50, News. 10.5, News in German. 10.10, Record. 10.15, See **Bratislava-Ostrava**. 11.0, Record. 11.15, How Stanley found Livingstone—Play for Schools. 11.50, Record. 11.55, Market Prices; Weather. 12 Noon, Time; Discussion for Farmers. 12.10 p.m., Records. 12.20, News. 12.30, See **Bratislava**. 1.30, Talk on Economics. 1.40, Records. 1.50, Exchange. 1.55, Exchange and Weather in German. 2.0, Interval. 3.15, See **Brno**. 4.15 to 4.20, Exchange; Weather. 5.40, Record. 5.45, Announcements. 5.50, Topical Talk for Farmers. 6.0, Record. 6.5, Market Prices. 6.15, Record. 6.20, German Transmission; Talk; Readings. 6.55, News in German. 7.0, Time; News. 7.10, See **Bratislava**. 7.25, Talk on the following Relay. 7.30, Aida—Opera, in Four Acts (Verdi), relayed from the State Opera House; Conductor, Milan Zuna. 10.55, News in English. 11.10, Close Down.

RJUKAN.—Relays Oslo.

ROME

Call 1RO, 713 kc/s, 420.8 metres; 50 kW. Relayed by Naples, 1,104 kc/s, 271.7 metres; Milan, No. 2, 1,348 kc/s, 222.6 metres; Turin, No. 2, 1,357 kc/s, 221.1 metres; and 2RO, 11,810 kc/s, 25.4 metres.—7.30 a.m., Gym. 7.45, Time; News. 8.0, Interval. 12.30 p.m., Records. 1.5, See Milan. In the interval at 1.30, Time; News; Exchange. 2.15, Interval. 4.30, Children's Radio Review. 4.55, News; Exchange. 5.5, Recitations. 5.10, Concert of Light Music: El caballero (Rossi); Waltz (Fall); Memorie (Petralla); Serenata alla amorosa (Frontini); Extract from The Barber of Seville (Rossini); Serenata bruna (Rosati); Lamento di Federico (Cilea); Extract from La donna perduta (Pietri); Lullaby (de Micheli). 5.55, Weather. 6.0, Corn Prices. 6.10 to 6.15, Atmospheric Signals. 7.0, Announcements. 7.15, News in Foreign Languages. 8.0, Time; News. 8.10, Records. 8.30, Government Notes. 8.45, Chamber Music; Brunetti (Pianoforte), Manno and Finardi (Violin), Svesco (Viola), Martorana (Cello) and Prokopien (Bass); Pianoforte Quintet Op. 44 (Schumann); Aria from Sadko (Rimsky Korsakov); My Mother (Moniuszko); Death (Gretchaninov); Two Russian Folk Songs. 9.30 (approx). La chionia de Berenice—A One-Act Play (Guglielminetti). 10.15, Dance Music. 11.0, News.

RUYSSSELEDE

10,330 kc/s, 29.84 metres; 8 kW.—7.45 p.m., News in French. 8.0, See **Brussels (No. 1)**. 8.45, Tchaikovsky Records: (a) Danse arabe, (b) Danse chinoise, (c) Valse des fleurs. 9.0, News in Flemish. 9.15, Close Down.

SALZBURG.—Relays Vienna.

SCHENECTADY

WGY 790 kc/s, 379.5 metres; 50 kW. Relayed at intervals by **W2XAF**, on 31.48 metres; and **W2XAD**, on 19.56 metres.—7.0 p.m., Irving Aaronson and his Orchestra. 7.15, WGY Matinee Players. 7.30, Women's Radio Review; Talks; Orchestra. 11.25, Exchange. 12 Midnight, Leo Reisman's Orchestra, with Phil Ducey. 12.30 a.m. (Wednesday), Wayne King and his Orchestra. 1.0 to 3.0, Popular Programme.

SOTTENS

677 kc/s, 443.1 metres; 25 kW; and Geneva, 401 kc/s, 748 metres.—7.0 to 7.15 a.m., Gym. 12.29 p.m., Time; News. 12.40 (from Geneva), Records. In the interval at 1.0 p.m., Exchange. 2.0, Interval. 3.59, Time. 4.0, Concert by the Small Radio Lausanne Orchestra; Conductor: Moser; Overture, Così fan tutte (Mozart); Minuet and Finale from the London Symphony (Haydn); Mozart Potpourri (Tchaikovsky); Village Dances (Beethoven). 4.35, Dance Music. 4.50, Records. 5.5, Chamber Music. 5.30, Light Music. 5.45, Dance Music. 6.0, Readings. 6.20, Concert by the Small Radio Lausanne Orchestra: Part I—Folk Music; Part II—Light Music. 7.0, Talk: The Valais Vintage Festival. 7.20, Dance Music by the Radio Lausanne Jazz Band. 8.0, Talk: The Jura Mountains. 8.30, Jura Programme, relayed from **Tramelan**; The Tramelan Choir; Conductor: Vouarnard. In the interval, Talk: The Tramelan Art Gallery. 9.15, News. 9.25, Recital by Gentil (Violin), Lévy (Cello) and Gentil (Pianoforte). 10.15 (from Geneva), Talk: The Work of the League of Nations. 10.30 (approx.), Close Down.

STOCKHOLM

704 kc/s, 426.1 metres; 55 kW.—Relayed by **Boesen** and **Ostersund**, 413.5 kc/s, 726 metres; **Göteborg**, 941 kc/s, 318.8 metres; **Hörby**, 1,131 kc/s, 265.3 metres; **Motala**, 216 kc/s, 1,389 metres; and **Sundsvall**, 601 kc/s, 499.2 metres.—7.20 a.m., Gym. 7.45, Service. 8.0, Weather. 12.30 p.m., Weather. 12.55, Time. 1.0, Swedish Lyrics and Music—Programme by Hedengran (Readings), Hahn (Pianoforte) and Hylbom (Violin). 1.45 (from Göteborg), Orchestral Concert of Light

Music. 2.45, Talk in English: The Rush Hour, relayed from Malmö, 1,312 kc/s (228.7 metres). 5.0, Weather. 5.5, Programme for Children. 5.45, Records. 6.45, Elementary French Lesson. 7.30, Jacob von Thyboe—Comedy (Holberg). 9.0, Concert by the Station Orchestra; Conductor: Wiklund; Suite, Master Olof (Aulin); Two Pieces for Strings (Wiklund); Hungarian Rhapsody No. 1 (Liszt). 9.45, Weather; News. 10.0, Orchestral Concert; Conductor: Wiklund; Soloist: Eckerberg (Pianoforte); Variations on a Theme of Haydn (Brahms); Pianoforte Concerto in C Minor, No. 24 (Mozart); Overture, Prometheus (Beethoven). 11.0 (approx.), Close Down.

STRASBOURG

859 kc/s, 349.2 metres; 15 kW.—11.0 a.m., Programme from Lyons (La Doua). 12 Noon, Records. 12.45 p.m., News. 1.0, Time; Exchange. 1.5 to 2.0, Orchestral Concert; Conductor, de Villers; Spanish Dances (Fallá); Overture, Cigale et Magali (Casadesu); Selection from Carmen (Bizet); Hungarian Rhapsody No. 2 (Liszt); Suite from The Chocolate Soldier (O. Strauss); March, Pomp and Circumstance (Elgar). 4.45, Talk: Tunis. 5.0, Concert from Grenoble, P.T.T., 986 kc/s, 309.9 metres. 6.0, Legal Talk in German. 6.15, Topical Talk. 6.30, Orchestral Concert; Conductor, Koskam; Overture, Paragraph III (Suppé); Foxtrot (Allouche); Serenade (Moszkovsky); Waltz Potpourri (Salabert); Selection from The Girl in the Taxi (Gilbert); Tango (Mora and Merin); Saxophone and Pianoforte: Valse lente (Guntz); Sittin' on a Backyard Fence (Kahal and Fain); Patronille galante (Lachaux); I ain't Lazy (Franklin); March, Piccadilly (Benoit). 7.30, Time; News. 7.50, See **Paris (Ecole Supérieure)**. In the interval, Press Review in German; Lottery Results; Announcements.

STUTTART

MUHLACKER, 574 kc/s, 522.6 metres; 100 kW.—5.35 a.m., Notes for Farmers. 5.45, Hymn; Time; Weather. 5.50, Gym. 6.15, Concert by the Philharmonic Orchestra from Mannheim. In the interval at 6.40, Time; Announcements; Weather. 8.10, Weather. 8.15, Gym. 8.35, Water-Level. 8.40, Interval. 10.0, News. 10.10, French for Schools. 10.35, Accordion Recital of Scandinavian Music by Alfred Kaul: Two Pieces (Sinding); (a) Song, (b) Folk Melody; Two Pieces (Sjögren); (a) Legend No. 6, (b) Legend No. 13; Five Pieces (Grieg); (a) Ballad Melody, (b) Melody in C, (c) The Lonely Wanderer, (d) Erotic, (e) Album Leaf. 11.0, Brahms Lieder by Käthe Ivers. 11.25, Announcements; Records. 11.55, Weather. 12 Noon, See **Frankfurt**. 1.0 p.m., Local News. 1.20, See **Frankfurt**. In the interval at 1.50, News. 2.30 to 2.50, Talk for Women. 3.30, Violin Recital by Gerda Reichert: Sonata No. 3, Op. 137 (Schubert); Minuet and Rondo in G (Beethoven). 4.0, Concert by the Station Orchestra; Conductor: Görlich; Soloists: Gross and Thomas (Violins), Hantz (Guitar), Thaler (Accordion); Overture, The Princess of the Golden Slippers (Rust); Fairy Suite (Ketelbey); Waltz (Waldteufel); Suite Campetere (Amadei); Interlude: Old Viennese Dances by the Station Schrammel Quartet; March (Latann); Overture, A Night in Venice (Joh. Strauss); In the Harbour of Port Said (Lautenschläger); Waltz (Ziehrer). 5.30, Recital by Elisabeth Jentsch (Soprano), Jantz (Tenor), and Jentsch (Baritone). 6.0, Hints for Amateur Picture Collectors. 6.15 to 6.45, See **Frankfurt**. 6.45, Variety Programme from Karlsruhe. 7.30, Dance Music. 7.45, Time; Weather; Notes for Farmers. 8.0, News. 8.10, Wildernesses and Steppes in South Germany—What the Excavations at Tröching Reveal. 8.35, Folk Music by the Mönschen Trio and Soloists. 9.10, Concert by the Station Orchestra. 10.20, News. 10.35, Topical Talk. 10.45, Local News. 11.0, Concert by the Station Orchestra. 12 Midnight, See **Frankfurt**. 1.0 a.m. (Wednesday), Close Down.

SUNDSVALL.—Relays Stockholm.

TOULOUSE

913 kc/s, 328.6 metres; 10 kW.—8.0 a.m., Dance Refrains. 8.30, News. 8.35, Light Music. 12 Noon, Opera Music. 12.15 p.m., Chansonnettes. 12.30, News; Exchange. 12.45, Request Music. 1.0, Market Prices. 1.5, Music by a Viennese Orchestra. 1.30, Sound Film Music. 1.45, Accordion Solos. 2.0, Amusement Guide. 6.0, News. 6.15, Opera Music: Transformation Music from Parsifal (Wagner); Prelude to the Third Act of The Mastersingers (Wagner); Overture, Figaro (Mozart). 6.30, Songs. 6.45, Orchestral Music. 7.0, Operetta Airs. 7.15, Marches. 7.30, News; Exchange. 7.45, Opera Music: Arias from (a) Thaïs (Massenet), (b) La Bohème (Puccini), (c) La Traviata (Verdi), (d) Werther (Massenet). 8.15, Symphony Orchestra: Mascara (Lacôme); Overture, Egmont (Beethoven). 8.30, Chansonnettes. 9.0, Hunting Horn Music. 9.30, Sound Film Music. 10.0, Light Music by a Viennese Orchestra. 10.15, News. 10.30, Chansonnettes.

11.0, Cinema Organ Music. 11.15, Opera Arias: Arias from (a) Figaro (Mozart), (b) Tales of Hoffmann (Offenbach), and (c) Scheherazade (Ravel). 11.30, Light Music. 11.50, Choral Music. 12 Midnight, News. 12.5 a.m. (Wednesday), Au cabaret de Minuit—Radio Fantasy. 12.15, Music by an Argentine Band. 12.30 (approx.), Close Down.

TRONDHEIM.—Relays Oslo. **TURIN**.—Relays Milan.

VATICAN CITY

15,120 kc/s, 19.84 metres; 10 kW (Morning); 5,970 kc/s, 50.26 metres (Evening).—11.0 to 11.15 a.m., Religious Information in English. 8.0 to 8.15 p.m., Religious Information in Italian.

VIENNA

592 kc/s, 506.8 metres; 120 kW. Relayed by Graz, 886 kc/s, 338.6 metres; Innsbruck, 519 kc/s, 578 metres; Klagenfurt, Linz, and Salzburg, 1,294 kc/s, 231.8 metres.—9.0 a.m., News. 9.20, Market Prices. 9.30, Weather. 10.50, Water-Level. 11.30, Records of Alpine Music. 11.55, Weather. 12 Noon, Classical Records. In the interval at 1.0 p.m., Time; News. 2.0, Announcements. 3.30, Time; Weather; Exchange. 3.50, Programme for Women. 4.10, News. 4.15, Programme for Children. 4.40, Recital by Irene Königshofer-Rethy (Soprano) and Olga Höfler-Schuch (Pianoforte); Arias from Figaro (Mozart); Il Trovatore (Verdi) and Oberon (Weber); Pianoforte Solos: Pastorale in E minor (Scarlatti); Gavotte in B minor (Bach-Saint-Saëns); Two Pieces from the Suite, Woodland Sketches (MacDowell): (a) To a Wild Rose, (b) Will o' the Wisp; Arabesque (Debussy); Rhapsody in G minor, Op. 79 (Brahms). 5.10, Talk: The Return Sixty Years Ago of the Austrian North Pole Explorers. 5.35, Records. 6.5, Talk: Wolf-Ferrari's Opera, Sly. 6.25, Talk: The Faculty of Commerce at Vienna University. 6.40, Technical Talk. 7.0, Time; Announcements; Weather. 7.10, Topical Talk. 7.30, Concert of Italian Chamber Music by the Vienna Symphony Orchestra; Conductor, Schönherr; Soloists: Felier (Tenor) and Rosner (Violin); Festival Overture (Cardoni); Neapolitan Suite (de Michelis); Lotta (Buzzi-Peccia); Addio bel sogno (de Curtis); Funiculi-Funicula (Denza); Extracts from the Suite, Oriental Impressions (Amadei); Mal d'amore (Pecchia); Marechiarè (Tosti); Torna a Sorrento (de Curtis); Intermezzo (Giordano); Serenata for Violin (Toselli); Tarantella (de Crescendo); Rosa Catena (Mignone); 'O surdato 'nnamurato (Canino); Three Pieces (Calotta): (a) Interlude, (b) Burlesque, (c) Festa di Maggio; Potpourri of Folk Songs (Acerbi). 8.50, Der Tod des Tizian—One-Act Play (Hugo von Hofmannsthal); Das Apostelspiel—One-Act Play (Maxwell). 10.20, Literary Competition: Finding a Poet for an Unfamiliar Schubert Lied. 10.30, News. 10.50, Dance Music. 12.30 a.m. (Wednesday), Records of Light Music. 1.0 (approx.), Close Down.

WARSAW

223 kc/s, 1,345 metres; 120 kW.—6.45 a.m., Hymn. 6.48, Records. 6.58, Gym. 7.8, Records. 7.15, News. 7.25, Records. 7.35, Hints for Housewives. 7.40, Programme Announcements. 7.50, Announcements. Light Music. 8.0, Interval. 11.57, Time. 12 Noon, Fanfare from St. Mary's Church, Cracow. 12.3 p.m., Weather. 12.5, Press Review. 12.10, Concert by the Lawrusiewicz Hawaiian Guitar Orchestra. 12.45, Programme for Children. 1.0, News. 1.5, Viola and Cello Records. 1.30, Interval. 3.30, Announcements. 3.35, Exchange. 3.45, Concert of Light Music by the Grossman Orchestra; Waltz, Manola (Waldteufel); Creol Serenade (Fronde); Argentine Tango, Hermosa (Borsatto); Slow Foxtrot (Adams); Foxtrot (Sperino); Selection from Viktoria and her Hussar (Abraham); Serenade (Gounod); Boston Waltz and Foxtrot from Frasquita (Lehnér). 4.45, Letterbox. 5.0, Violin Recital by Dvorakowski: Sarabande (Bach); Presto from Sonata No. 11 (Porpora-Bachmann); Crepuscule (Halvorsen); Valse lente (Merikanto-Burmester); Mazurka (Izycki); Hungarian Piece (Janichnow). 5.25, Talk. 5.35, Records: Light Music. 5.50, Letterbox. 6.0, Programme for Farmers. 6.10, Art Notes. 6.15, Bass Solos by Serge Benoit; Aria from Les Huguenots (Meyerbeer); Death (Gretchaninov); Arias from the Queen of Spades (Tchaikovsky); Prince Igor (Borodin) and Boris Godunov (Mussorgsky); Ballad (Rubinstein). 6.45, Literary Sketch. 7.0, Concert by a Mandoline Orchestra from Poznan, 868 kc/s, 345.6 metres. In the interval at 7.20, Topical Talk. 7.45, Programme Announcements. 7.50, Sports Notes. 8.0, Viennese Concert by an Orchestra, The Reveliers Choir, Schrammel Quartet and Soloists, relayed from **Lwow**, 795 kc/s, 377.4 metres. 8.45, News. 8.55, Talk. 9.0, Concert by the Station Symphony Orchestra; Conductor, Mierzewski; Soloist, Dudicz (Songs); Overture, The Countess (Moniuszko); Aria from Goplana (Zelen-ski); Overture, The Thieving Magpie (Rossini); Arias from The Tales of Hoffmann (Offenbach) and Romeo and Juliet (Gounod); Symphonic Dance (Grieg); Ballet Music from Faust (Gounod). 10.0, Announcements; Light Music. 10.15, Dance Music from the Adria Café. In the interval at 11.0, Weather.

ZURICH.—Relays Beromünster.

WEDNESDAY

SEPTEMBER THE TWENTY-SIXTH

ATHLONE

565 kc/s, 531 metres; 60 kW. Relayed by Dublin, 1,348 kc/s, 222.6 metres; and Cork, 1,240 kc/s, 241.9 metres.—1.30 to 2.30 p.m., Time Signal; Exchange; Weather; Records. 4.0, Concert by the Savoy Instrumental Quartet; Soloists, Philip Dore (Organ), J. C. Doyle (Songs). 6.0, Programme for Children. 6.45, News. 7.0, Irish Lesson. 7.15, German Lesson. 7.30, Time Signal; Band Concert. 8.30, Song Recital by A. J. O'Farrell (Baritone). 8.40, Pianoforte Duets by Alice Bell and Dorothy Stokes. 8.50, Song Recital by A. J. O'Farrell (Baritone). 9.0, Pianoforte Duets by Alice Bell and Dorothy Stokes. 9.10, Song Recital by Nan Daly (Soprano). 9.20, Play, presented by E. Young and Company. 9.50, Accordion Solos by M. Grogan. 10.0, Variety Programme. 10.30, Time Signal; News; Weather. 10.40, Records. 11.0 (approx.), Close Down.

BARCELONA

795 kc/s, 377.4 metres; 5 kW.—8.15 a.m., News, Records. 9.0, Chimes; Gym; Records. 9.20, News; Records. 10.0, Obituary. 12 Noon, Chimes; Weather. 1.0 p.m., Programme for Women. 1.45, Records. 2.0, Records. 2.30, Theatre Notes; Amusement Guide; Records. 3.0, Sextet Concert. 4.0, Programme for Hospitals. 5.0, News. 5.30, Interval. 7.0, Concert by the Station Trio. In the interval at 7.30, News. 8.0, Request Records. 8.30, Exchange; Talk for Women. 9.0, Wireless Notes. 9.10, Records. 9.30, Geography and History Lesson. 9.45, Press Review. 10.0, Chimes; Weather; Social Notes; Exchange. 10.10, Concert by the Station Orchestra: March (Haber); Selection, Los Pápiras (Luna); Waltz (Rust); Minuet (Filipicci); Serenade (Tchaikovsky); Overture, Fingal's Cave (Mendelssohn). 11.0, Two Catalan Plays: (a) Tal hi va qui no s'ho creu—One-Act Comedy (Vidal-Valencià). (b) La Vivor de l'Estornell One-Act Comedy (Solé). 1.0 a.m., (Thursday), News. 2.0 till Close Down. Programme in English by the International Broadcasting Company of London. 2.0, Village Life—Concert. 2.30, Orchestral Music. 3.0, I.B.C. Goodnight Melody and Close Down.

BASLE.—Relays Beromünster.

BELGRADE

686 kc/s, 437.3 metres; 2.5 kW.—10.45 a.m., Programme Announcements. 10.50, Water Level. 11.0, Records. 11.59, Chimes. 12.5 p.m., Concert by the Station Orchestra. 12.45, Exchange; Announcements. 1.10, Concert by the Station Orchestra. 1.30, News; Time. 4.0, Talk. 4.30, Concert by the Station Orchestra: Overture, The Black Domino (Auber); Potpourri (Domenici); Piece (Mokranjatz); Selection from Aida (Verdi); Waltz, Wienerkinder (Strauss); Gallop (Eilenburg). 6.25, Time; Programme Announcements. 6.30, French Lesson. 7.0, Records. 7.10, Announcements. 7.20, Records. 7.30, Talk. 8.0, An Opera, relayed from Ljubljana, 527 kc/s, 569.3 metres. In an interval at 10.0, Time; News.

BERLIN

DEUTSCHLANDSENDER, 191 kc/s, 1,571 metres; 60 kW. 5.30 a.m., Weather; News. 6.0, Gym. 6.15, Motto. 6.20, See Königsberg. In the interval at 7.0, News. 8.0, Interval. 8.45, Gym. for Women. 9.0, Interval. 9.40, Gym. for Children. 10.0, News. 10.10, See Hamburg. 10.50, Programme for Children. 11.15, Weather. 11.40, Interval. 11.55, Weather. 12 Noon, See Breslau. 12.55 p.m., Time. 1.0, Record of Drinking Songs. 1.45, News. 2.0, Interval. 2.45, Greetings; Announcements. 3.0, Weather; Exchange. 3.15, Sun, Wind, and Rain—Songs by Children. 3.40, Records of Love Songs. 4.0, See Munich. In the interval at 4.50, Weather. 5.30, Waltz Records. 6.0, Talk by Commander von Engendorff, of the Karlsruhe (on Records); My Impressions of America. 6.15, Birds in Music—Records. 6.30, Hermann Löns Programme—Stories, Ballads, and Songs to the Lute, by Oskar Essendorfer. 7.30, Elementary Italian Lesson. 8.0, News. 8.10, See Frankfurt. 8.30, Recital on Two Pianofortes by Jäger and Stech. 9.0, Talk by the Station Director. 10.0, News. 10.30, Talk: Can America Understand Germany? 10.45, Weather. 11.0, Weather Report for the Gordon-Bennett Balloon Race. 11.10, Waltz Records. 11.30, Concert of Danish Music from Kalundborg (on Records). 12 Midnight, Close Down.

BERLIN

FUNKSTUNDE, 841 kc/s, 356.7 metres; 100 kW.—6.0 a.m., Hymn; Gym. 6.15, Prayers. 6.20, See Königsberg. In the interval at 7.0, News. 8.0, Gym. 8.20 to 8.35, Physical Culture. 9.0 to 9.40, Dialect Reading (Hermann Löns). 10.0, News. 10.10, Exchange. 10.30, Records; News. 11.25 to 11.30, Exchange. 12 Noon, Concert by the Heyden Orchestra: Waltz, Toujours on jamaïs (Waldteufel); Violella (Busè); Serenade (Murrizi); Karlsruhe (Kiek-Schmidt); Siciliano (Schmalstieg); Madrigal (Bullerian); Piece (de Micheli); Two Guitars: Frühling und Liebe (Grothe); Serenata (Panizzi). In the interval at 12.30 p.m., Weather. 1.0, News. 1.15, Records. 2.0, News. 2.15, Chamber Music and Song Records. 3.0 to 3.20, Exchange. 4.0, See Königsberg. 5.30, Talk: Preparations for the

Olympic Games. 6.0, Announcements. 6.5, Talk for Mothers. 6.30, Recital of Contemporary Songs by Elisabeth Bauer-Hamann (Contralto); Songs (Heis): (a) Nun muss ich dich lassen. (b) Mitternacht-Glocke. (c) Mich quält der Raum. (d) Es ist ein Stern; Songs (Kurt Schubert): (a) Abend im Feld. (b) Ein Marienlied. (c) Zweier Seelen Lied. (d) Der Spuk. 6.50, String Quartet in C Minor, Op. 19 (Busoni) by the Bruiner Quartet. 7.20, Community Singing. 7.40, Echoes of the Day. 8.0, News. 8.10, Mozart Recital by Heinrich and Carl Steiner: Sonatas for Violin and Pianoforte in E Flat and A. 8.35, Talk for Young People: The Thirty Years' War. 9.0, Over the Moor—Hermann Löns Anniversary Sequence, with Incidental Music. In the interval, Reminiscences of Hermann Löns by his Brother, Ernst. 10.20, News. 10.50, Records of Light Music and Dance Music. 1.0 a.m. (Thursday), Close Down.

BERNE.—Relays Beromünster.

BEROMUNSTER

556 kc/s, 539.6 metres; 60 kW.—12 Noon, Records; Ballet Suites. 12.29 p.m., Time Signal from Neuchâtel Observatory; News. 12.40, Records; Light Music. 1.25, Time; Weather; Exchange. 3.30, Talk for Women. 3.59, Time Signal from Neuchâtel Observatory. 4.0, Concert of Russian Music. 4.45, Classical Dances. 5.15, Records; Viennese Waltzes. 5.30, Viennese Songs and Duets. 5.50, Records. 6.0, Programme for Children. 6.30, Talk: The Fur Industry in Switzerland. 7.0, Time; Weather; Market Prices. 7.30, Talk: The Chemist. 7.50, National Dances by the Station Orchestra; Conductor, Hofmann. 8.30, Jakob Bühler reads from his own Works. 9.0, News. 9.10, Twelve Chorals for Organ. 9.50, Talk: The Zürich Stamp Exhibition. 10.15 (approx.), Close Down.

BODEN.—Relays Stockholm. BODO.—Relays Oslo.

BRATISLAVA

1,004 kc/s, 298.8 metres; 13.5 kW.—6.0 to 7.15 a.m., See Prague. 9.45, Announcements. 9.50, See Prague. 10.10, News in Hungarian. 10.15, See Moravská-Ostrava. 11.0, Water Level. 11.5, Concert by the Station Orchestra; Conductor, Dyk. 11.55, See Prague. 12 Noon, Talk for Farmers. 12.10 p.m., Local News in Slovak. 12.15, Record. 12.20, See Prague. 12.30, See Moravská-Ostrava. 1.40, News and Weather in German and Hungarian. 1.50 to 2.0, See Prague. 3.15 to 4.20, See Prague. 5.30, Viola Recital by Lily Kratochvílová: Sonata in E minor (Rubinstein). 6.0, Talk. 6.10, Talk for Housewives. 6.15, Hungarian Transmission: Sports Notes; Recital of Árpád Balázs: Songs by Renée Szogyová; Educational Talk. 6.55, See Prague. 7.10, Pianoforte Recital by L. Svobodová. 7.35, Talk: The New Russian Theatre. 7.50, Violin Recital by G. Pauliny; Chaconne (Bach); Minuet (Beethoven-Burmester); Serenade (Pierné); Piece from The Violin-Maker of Cremona (Hubay). 8.15, See Prague. 10.45, News in Hungarian. 11.0, Close Down.

BREMEN.—Relays Hamburg.

BRESLAU

950 kc/s, 315.8 metres; 60 kW. Relayed by Gleiwitz, 1,231 kc/s, 243.7 metres.—5.0 a.m., Hymn; Motto; Records. In an interval at 5.40, Weather. 6.0, Time; Weather; Gym. 6.25, Orchestral Concert. In the interval at 7.0, Time; News. 8.40, Gym. for Women. 9.0, Time; News. 10.10 to 10.40, Löns Lieder Recital by Lotte Neumann with Lute Accompaniment. 11.30, Time; News. 11.45, Talk: Hermann Löns, the Peasant Author. 12 Noon, Concert by the Station Orchestra; Conductor, Topitz. In the intervals at 12.30 p.m., Time; Weather; and at 1.30, Time; News. 2.20, Exchange. 2.25, Announcements; Records. 2.50, Market Prices. 3.10, Book Review. 3.30, Handwork for Children. 4.0 (from Gleiwitz), Concert by the Glück auf Orchestra; Conductor, Gichnik: March (Hoffmann); Burlesque Overture (van der Misset); Waltz (Lühr); Zirkus-volk (Kark); Russian Fantasia—(Grothe-Kirchstein); Serenade, AIDA (Meis-Ed); Waltz (Moised); Parade of the Clowns—(Herzberg); March Song, Uns gehört die ganze Welt (Schmalstieg). 5.15, See Leipzig. 5.30, Announcements. 6.0, Contralto Recital by Elisabeth Wolfsegger: Der Tod und das Mädchen (Schubert); Des Mädchens Klage (Schubert); An ein Veilchen (Bräms); Sapphische Ode (Bräms); Ruhe meine Seele (R. Strauss); Alterszeiten (R. Strauss). 6.30, Programme to be announced. 6.50, Announcements. 7.0, Nun hilf uns Gott und unser blanke Waffen—Play with Sixteenth Century Folk Songs (arr. Wittkowski); The Station Choir, the Station Orchestra and Soloists;

BRUSSELS (No. 2)

932 kc/s, 321.9 metres; 15 kW. Programme in Flemish.—11.57 a.m., Weather. 12 Noon, Records of Light Music. 1.0 p.m., News. 1.10, Orchestral Concert: Overture, La-strata (Lincke); Waltz, Mon rêve (Waldteufel); Fantasia on Flemish Songs (Walpot); First Waltz Potpourri (Robrecht). 2.0, Interval. 4.55, News. 5.0, Concert by the Radio Orchestra; Soloist, Béthune (Violin); Trois pages—(Bruscellians); Bosphorus (Bayens); Piece (Bokalanikoff); Arlequinade (Cazaneuve); First Suite (Guiraud); Romance for Violin (Svendsen); Fresques (Gaubert); Norwegian Dances (Grieg). 6.0, Choral in A minor (Frank) on Records. 6.30, Sonata Recital by Scharris (Pianoforte) and Pitsch (Cello); Sonata No. 2 (Bach); Sonata No. 3 (Beethoven). 7.0, Act IV of Mephistopheles (Boito) on Records. 7.30, News. 8.0, Promenade Concert relayed from London. 9.35, Sketch (Ballad). 9.55, Promenade Concert (cont.). 10.25, News. 10.35, Dance Music relayed from Brussels (No. 1). 11.0 (approx.), Close Down.

BUCHAREST

823 kc/s, 364.5 metres; 12 kW.—12 Noon, Water Level; Records. 12.45 p.m., Amusement Guide; Exchange; Records of Light Music. 1.15, Time; Weather; News. 1.40, Records of Light Music. 5.0, Concert by the Station Orchestra: Overture, The Ace of Hearts (Kinkeke); Waltz (Tauslateur); Traumland (Fück); Waltz from Eine Ballnacht; Waltz (Ziehrer); Waltz, Die Kossenden (Lammer); Waltz (Fall); Overture, Antony and Cleopatra (Zere). 6.0, Time; Weather; News. 6.15, Concert of Modern French Operetta Music; Selections from l'Éau à la bouche (Pares-Parys); Bonche à Bonche (Yvain); Deshabillez vous (Mercier); No, No, Nanette (Youmans). 7.0, Educational Programme. 7.15, Records. 7.45, Talk. 8.0, Stan Golestan Concert: Soloists, Gimist Brissou and Filippescu (Pianofortes); Jioun (Flute); Ghiesu (Viola); Metani (Clarinet); Alie, Bohesco (Violin); Zelinsky (Oboe); Sonata for Pianoforte and Flute; Arioso and Allegro from the Concerto for Viola and Pianoforte; Elegue for Clarinet and Pianoforte; Piece for Violin and Pianoforte; Elegy and Folk Songs for Oboe and Pianoforte; Pastorale; Records; String Quartet No. 1 in A flat. 10.0, News.

BUDAPEST

546 kc/s, 549.5 metres; 120 kW.—6.45 a.m., Gym. 9.45, News. 10.0, Two Talks. 12 Noon, Chimes from the University Church. 12.5 p.m., Popular Concert. 1.30, Records. 4.0, Programme for Students. 5.0, Medical Talk. 5.35, Concert by the Toll Cigány Band. 6.50, Talk. 7.25, Choral Concert. 8.15, Reading. 8.50, Concert by the Budapest Concert Orchestra. Conductor, Polgár. Soloist: Rozsi Walter (Songs). Overture, The Crown Diamonds (Auber); Aria from Le Cid (Masse-net); Danse macabre (Saint-Saëns); Selection from Oberon (Weber); Piece (Weiner); Suite (Bortkiewicz). 10.15, News. 10.35, Concert by the Veres Cigány Band from the Café Ostende, followed by Dance Music.

CASSEL.—Relays Frankfurt.

COLOGNE

658 kc/s, 455.9 metres; 60 kW.—5.30 a.m., Hymn; Records. 6.5, Gym. 6.25, See Breslau. In the interval at 6.50 Time; News. 8.0, Time; Announcements. 8.5, Gym. for Women. 8.20 to 8.30, Talk for Mothers. 10.0, Time; News. 10.10, Hermann Löns Anniversary Programme for Schools. 11.10, Announcements. 11.40, Legal Talk. 12 Noon, Song Records. 12.45 p.m., Announcements; Greetings. 1.0, Concert by the Augmented Station Orchestra; Conductor, Kihm; Soloists, Schreiber (Cello) and Hans Hauss (Pianoforte); Minuet from the Hauffen Symphony (Mozart); Adagio from the Cello Concerto (Haydn); Slerzo from Symphony No. IV (Beethoven); Air from the Suite in D (Bach); Scherzo from the Rhine Symphony (Schumann); First Movement from the Pianoforte Concerto in B flat minor (Tchaikovsky); Allegro con grazia from the Pathetic Symphony (Tchaikovsky). In the interval at 1.45, Announcements. 3.0, Sports Report. 3.30, Exchange. 3.50, Topical Talk. 4.0, See Hamburg. 5.0, Book Review. 5.20, Chamber Music by Children; Conductor, Abshagen. 6.45, Talk: A Tour of Italy, Suilly and Topoli. 6.0, Industrial Review. 6.20, Hermann Löns Memorial Programme. 6.40, Topical Talk. 6.50, Exchange; Sports Notes. 7.0, Concert by the Small Station Orchestra; Conductor, Eysoldt: Prelude to Nakhis Hochzeit (Lincke); Waltz, Donau-sagen (Fück); Selection from Aida (Verdi); Love's Dream after the Ball (Zubinka); Sizzietta (Blon); Six Bravoura Variations on the Folk Song, Muss i denn zum Städle hinaus (Knümann); Bib und Bob (Demareit); March, Diabolos (Mauss). In the interval at 7.30, A Flying Visit. 8.0, News. 8.10, See Frankfurt. 8.35, See Berlin (Funktunde). 9.0, See Munich. 10.0, Time; News. 10.35, Light Music and Dance Music by the Schlenkermann Orchestra relayed from Elberfeld. 12 Midnight, Close Down.

COPENHAGEN.—Relays Kalundborg. CORK.—Relays Athlone. DANZIG.—Relays Königsberg. DRESDEN.—Relays Leipzig.

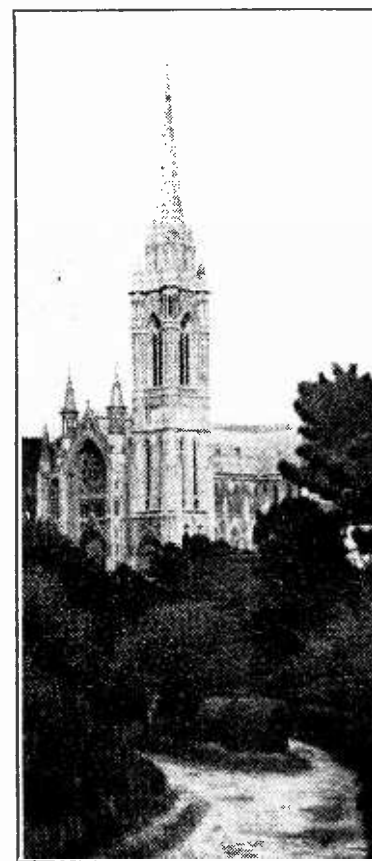

CARILLON RECITALS are frequently relayed from St. Colman's Cathedral, Queenstown, seen above, by the Athlone, Dublin and Cork stations.

5.40, Hints for Housewives. 5.45, German Transmission; Talk; Recitations. 6.20, Talk for Students. 6.30, Records. 6.45, Talk for Workers. 6.55, See Prague. 7.35, Talk: The Baikal. 7.50, Sonata in B minor (Chopin) by Marie Dvorakova (Pianoforte). 8.15, See Prague. 11.0 (approx.), Close Down.

BRUSSELS (No. 1)

620 kc/s, 483.9 metres; 15 kW.—11.55 a.m., Weather. 12 Noon, Orchestral Concert: Soloist, Pol Gilson (Songs); Wedding March (Paradisi); Overture, The Thieving Magpie (Rossini); Songs: (a) Aria from L'ombre Flotante. (b) Un rien (Dammie); Selection from Rigoletto (Verdi); Violin; Tambourin chinois (Kreisler); Songs: (a) Air from Aïon-Hamet (Dubois). (b) Because (d'Hardelot); Ballet Music from Les myrtilles Dionysiaques (Ma-senet). 1.0 p.m., News. 1.10, Popular Records. 2.0, Interval. 4.55, News. 5.0, Dance Records. 6.0, Talk: Free Thought. 6.15, Orchestral Concert of Light Music: Soloist, Duquesne (Trumpet). 7.15, Debussy Records. 7.30, Medical Talk; Announcements. 8.0, Concert Version of L'île Time—Operetta (Schubert-Berté). In the interval at 9.0, The Bear—One-Act Farce (Teliekov). 10.0, News. 10.10, Dance Music by the Schuyders Band. 11.0 (approx.), Close Down.

SEPT. 26th **WEDNESDAY** continued

FECAMP

1,456 kc/s, 206 metres; 10 kW.—11.30 a.m. to 12 Noon, Programme in English arranged by the International Broadcasting Company of London, Happy Half Hour: Request Programme. 12 Noon, Programme in French. 4.30 to 6.0 p.m., Programme in English arranged by the I.B.C. (London). 4.30, Isle of Wight, Portsmouth and Southsea Concert: Part I, Half an Hour with Schubert. 5.0, Part II, Dance Music. 5.30, Part III, Light Music. 6.0, Programme in French. 11.0 till Close Down, Programme in English arranged by the I.B.C. (London). 11.0, Talkie Time: Tunes from the Talkies and Shows. 11.30, Concert: Dance Music. 12 Midnight, Club Concert for Inveresk Listeners: Dance Music. 12.30 a.m. (Thursday), I.B.C. Time Signal. 12.31, Dance Music by Ambrose and his Orchestra (Gramophone Records). 1.0, I.B.C. Good-night Melody and Close Down.

FLENSBURG.—Relays Hamburg. **FLORANCE**.—Relays Milan.

FRANKFURT

1,195 kc/s, 251 metres; 17 kW.—5.45 a.m., Hymn; Time; Weather. 5.50, Gym. 6.40, Time; Announcements. 6.55, Military Band Concert. 8.10, Announcements. 8.15 to 8.35, Gym. 10.0, News. 10.10, Jungens im Sturm!—Sequence for Schools (Voss). 10.50, Household Hints. 11.0, Concert. 11.30, Announcements. 11.45, Social Service. 12 Noon, See Stuttgart. 1.0 p.m., Time; News. 1.20, See Stuttgart. 1.50, Time; News. 2.0, See Stuttgart. 2.30, Industrial Review. 2.45, Time; Exchange. 2.55, Weather. 3.10, **Trier-Freiburg-Kaiserslautern** Inter-Relay Programme: Six Hermann Löns Lieder (Edgar Hansen) by Maria Coomes-Strauss (Soprano), the Composer accompanying, relayed from Trier; Our Alemannic Heritage—Radio Picture (Paul), relayed from Freiburg; Trio in E flat for Flutes and Piano-forte (Siltz), relayed from Kaiserslautern. 4.0, See Königsberg. 5.30, Talk: Field-Marshal Count York of Wartenburg. 5.45, A Camping Sketch for Young People (Kuhmert). 6.20, Reading of Bismarck's Letters to his Wife. 6.35, German Lyrics (Linke). 6.45, Announcements. 6.50, Concert by the Station Orchestra; Conductor, Caspar: Overture, The Nuremberg Doll (Adam); Flower Waltz (Waldteufel); Selection from Die Fledermaus (Joh. Strauss); Entr'acte and Waltz from Coppélia (Delibes); Polka (Jones); Waltz (Waldteufel); March, Verliebte Brüder (Nedbal). 7.45, Topical Talk. 8.0, Time; News. 8.10, Topical Talk. 8.35, See Berlin (Funkstunde). 9.0, Dance Music by the Renner Band with Humorous Interludes. 10.20, Time; News. 10.35, See Stuttgart. 10.45, News. 11.0, Concert of Folk Music by Paul Haarer (Hermann Löns Lieder to the Flute), Eisele (Zither) and Uthicke (Accordion). 12 Midnight, See Stuttgart. 1.0 a.m. (Thursday), Close Down.

FREDRIKSSTAD.—Relays Oslo. **FREIBURG**.—Relays Stuttgart. **GENEVA**.—Relays Sottens. **GENOA**.—Relays Milan. **GLEIWITZ**.—Relays Breslau. **GOTEBORG**.—Relays Stockholm. **GRAZ**.—Relays Vienna. **HAMMAR**.—Relays Oslo.

HAMBURG

904 kc/s, 331.9 metres; 100 kW. Relayed by Bremen, Flensburg, and Hanover, 1,330 kc/s, 225.6 metres.—5.45 a.m., Time; Announcements. 6.0, Gym. 6.15, Time; Weather. 6.20, See Königsberg. In the interval at 7.0, Time; News. 8.0, Weather; Talk for Housewives. 8.10, Announcements; Records. 10.10, Hermann Löns Anniversary Programme for Schools. 10.50, News. 11.0, Humpty Dumpty—Radio Play in English for Schools (Grünwald). 11.30, Concert Version of La Bohème—Opera (Puccini) (on Records). 12 Noon, Household Hints. 12.5 p.m., Time; Announcements. 12.15, Concert relayed from Berlin (Funkstunde). 1.0, Exchange; Market Prices. 1.15, Weather. 1.20, Popular Music. 2.15, News. 2.30, Records—Music from Many Lands. 3.0, Exchange. 3.40, Shipping; Aviation. 4.0, Concert of Modern German Dances by the Station String Quartet, the Station Orchestra, and Girnatis (Pianoforte). Conductor, Maass. 5.30, Reading (Zukovsky). 6.50, German Dialect Ballads by Germer and Jakschtat (Songs), with Commentary. 6.30, Popular Records. 6.45, Exchange; Market Prices. 6.55, Weather. 7.0 (from Bremen). Military Band Concert. Conductor: Entelmann. Florentine March (Fueick); Overture, Martha (Plotow); Hungarian Dances, Nos. 5 and 6 (Brahms); Schatzwalzer (Joh. Strauss); Schmeichelkätzchen (Ellenberg); March Potpourri, Alte deutsche Treue (Frantzen); Intermezzo, Elfengedüster (Rhode). 8.0, News. 8.10, Talk: Bremen Cathedral (on Records). 8.35, See Berlin (Funkstunde). 9.0, The Diamond Seekers—Play (Heydreich). 10.0, News. 10.20 (from Kiel), Concert by the Neumünster Choir, relayed from the Oberlyzeum. Conductor: Klinker (Pianoforte). Soloist: Trude-Maria Schnell (Soprano). Glaube (Böttger); Lied des Volkes (Erdlen); Arias from (a) Iphigenia in Aulis (Gluck) and Tannhäuser (Wagner); Der träumende See (Schumann); Feldsamsamkeit (Wendell); Aria from Oberon (Weber); Von Freiheit und Vaterland (Goepfert); Mahnung (Heinrichs). 11.0 (from Hanover), Concert by the Hanover Chamber Orchestra, Conductor: von Sosen.

Overture, The Queen's Kerchief (Joh. Strauss); Finale from Arielle, die Tochter der Luft (C. P. E. Bach); Mazurka (Dvorák); Neapolitan Suite (de Michelis); Alpine Song Fantasia, Die Berge hoch! (Pachernegg); Paraphrase on the Song, Ich hört ein Vöglein pfeifen (Schauss); Old Styrian Dance, Bauerngalopp (Pachernegg). 12 Midnight, Close Down.

HANOVER.—Relays Hamburg.

HILVERSUM

160 kc/s, 1,875 metres; 7 kW. (until 3.40 p.m.). Transmitted from Kootwijk, 50 kW., from 3.40 p.m.—7.40 to 9.40 a.m., Programme of the Workers' Radio Society (V.A.R.A.). 7.40, Records. 9.10, Dietetics. 9.40, Religious Programme of the Liberal Protestant Radio Society (V.P.R.O.). 9.55 till Close Down, V.A.R.A. Programme. 9.55, Records and Talk for Workers. 11.40, Concert of Light Music. Conductor: v. d. Horst. Soloist: Booy (Songs). 12.25 p.m., Talk. 12.28, Organ Recital by Jong, Ballet Music from Sylvia (Delibes); Little man, you've had a busy day (Wayne); The musical box (Heykens); Piece (Warren). 12.55, (Concert of Light Music (contd.)). 1.25, Programme for Women. 1.40, Interval. 1.55, Dress-making Lesson. 2.40, Programme for Children. 5.10, Concert of Italian and Spanish Music. Conductor: Wins. 5.40, Concert by the Small V.A.R.A. Ensemble. Conductor: Bakels. Overture, Nina-Nini (Seelig); Melody (Arezzo); Extract from The Beggar's Opera (Gay); Movement from the Symphony, La Reine (Haydn); Records; L'Elfe dans la plaine (Brusselsmans); La serenata (Braga); Twilight (Cesek); Russian Songs (Delmas); La cathédrale engloutie (Debussy); Prelude to La demoiselle Elus (Debussy). 6.40, Sports Notes. 7.0, Organ Recital by Steyn. 7.20, Talk. 7.40, S.O.S. Messages. 7.43, Records. 7.55, Craignehille—Play (Anatole France). 8.40, Extracts from The Gipsy Princess (Kálmán) (on Record). 9.25, Talk. 9.28, Press Review. 9.40, Concert by the V.A.R.A. Orchestra. Conductor: de Groot. Overture, Il Guarany (Gomez); La verhera (Lacôme); Variations on a Theme of Tchaikovsky (Arensky); Marching Song (Grainger); Molly on the shore (Grainger); Tambourin chinois (Kreiser); Suite from Tsar Saltan (Rimsky-Korsakov). 10.40, Records. 11.40, Close Down.

HORBY.—Relays Stockholm.

HUIZEN

995 kc/s, 301.5 metres; 7 kW. (until 6.40 p.m.); 20 kW. from 6.40 p.m. Programme of the Christian Radio Society (N.C.R.V.).—7.40 a.m., Bible Reading; Prayer. 7.55 to 9.10, Records. 10.10, Religious Programme. 10.40, Organ and Soprano Solos by Jurjaanz and Mme. Neerden-Ongers. 11.40, Police Notes; Records. 12.10 p.m., Concert by the Amsterdam Chamber Orchestra, Conductor: Kiekens. Kleiner Wienermarsch (Kreiser); Overture, The Italian Girl in Algiers (Rossini); Czardas (Monti); Poème (Fibich); Suite (Dvorák); Records; Overture, Titus (Mozart); Two Indian Love Lyrics (Woodford-Finden); Bohemia (Fétras); Geisterreigen (Gluck-Barger); Hyde Park (Jalowicz). 1.40, Records. 2.40, Organ Recital by Liney. Selection from Lohengrin (Wagner); La Serenata (Braga); Suite orientale (Popy); Souvenir (van den Linden); Scherzi (Schubert); Träumerei (Schumann); Melody in F (Rubinstein); Florentine March (Fueick). 3.25, Interval. 3.40, Concert by the Hartvelt Trio. Trio in D (Leclair); Sonata for Violin and Pianoforte (Bordewijk-Roepman); Records; Trio (Smetana). 4.40, Programme for Children. 5.40, Talk for Farmers. 6.10, Programme to be announced. 6.40, Police Messages; Religious Notes. 6.55, Records. 7.10, Talk. 7.40, Choral Concert. Conductor: Vranken. Wie sich ein Vater erbarmet (Bach); Songs (Bach): (a) Letztes Glück. (b) Im Herbst: La bataille de Marignan (Jannequin); Den Uil (Diepenbroek); Records; Wilt heden nu treden (arr. Vranken, Jr.); Merck toch hoe sterck (arr. Vranken, Jr.); Heer Jezus heeft een hofken (van Duysse); Oene van Sneek (arr. Vranken, Jr.). 8.40, Talk: India. 9.10, Recital by Van Den Hurk (Flute), Dongen (Oboe), and Kloek (Organ). Trio Sonata in C minor (Loeillet); Oboe Concerto (Marcello); Flute Solo, First Movement from Symphony No. 7 (Widor); Duo concertant (Klose). In the interval at 9.40, News. 10.10, Records. 11.10 (approx.), Close Down.

INNSBRUCK.—Relays Vienna.

KALUNDBORG

238 kc/s, 1,261 metres; 75 kW. Relayed by Copenhagen, 1,176 kc/s, 255.1 metres; and Skamlebaek, 49.5 metres.—7.0 a.m., Gym. 8.30, Service from Copenhagen Cathedral. 11.0, Weather. 11.10, Fish Prices. 12 Noon, Concert by the Bendix String Ensemble, relayed from the Wivex. 2.0 p.m., Interval. 3.0, Records. 3.30, Concert by Preil's Instrumental Ensemble; Symphonic March (Savino); Waltz Potpourri (Winter); Hungaria (Black); Suite, A. Mediterranean

Cruise (Jalowicz); Valsette (Bazant); Metropolis (Grofé); Foxtrot (Rawicz); Persian Scene (Rust); Waltz, Schön ist die Welt (Lehár); Ein Cocktail in der Wunderbar (Katscher); Italian Serenade (Caludi); Songs (Rasbach); Foxtrot-Intermezzo (Schoppe-Laudschütz); When I am looking at you (Stothart); Two little Finches (Kling); Foxtrot (Rawicz). In the interval at 4.25 (approx.), Talk for Women. 5.30, Exchange. 5.45, Talk for Farmers. 6.15, French Lesson. 6.45, Weather; Announcements. 7.0, News. 7.15, Time. 7.30, Talk: Modern Industrial Conditions. 8.0, Chimes. 8.2, The Hansen Family—Humorous Sketch (Locher). 8.15, Danish Music by the Radio Orchestra; Conductor, Reesen: Overture, Der Erlenhügel (Kuhlau); Minnet from King and Marshal (Ileise); Prelude to Once upon a Time (Lange-Müller); King Christian X. Homage March (Andersen). 8.45, Missionary Address: Changes of Rule and Race in India. 9.15, Concert of Modern Danish Music by the Radio Orchestra; Conductor, Reesen: Carl Nielsen Potpourri (Reesen); Danish Folk Melody (Tarp); Memorial Suite (Rissager). 9.45, Report: A Lottery Draw. 10.10, News. 10.25, Concert of Scandinavian Music by the Radio Orchestra; Conductor, Reesen: Norwegian Rhapsody No. 4 (Svendsen); Selection from Swan White (Sibelius); Homage March from Sigurd Jorsalfar (Grieg). 11.0, Dance Music by Donde's Band, relayed from the Lorry. In the interval at 12 Midnight, Chimes. 12.30 a.m. (Thursday), Close Down.

KIEL.—Relays Hamburg. **KLAGENFURT**.—Relays Vienna.

KONIGSBERG

1,031 kc/s, 291 metres; 60 kW. Relayed by Danzig, 1,303 kc/s, 230.2 metres.—5.0 a.m., Records. 5.50, Weather. 6.0, Gym. 6.20 (from Danzig), Military Band Concert. In the interval at 7.0, News. 8.0, Prayers. 8.30, Gym for Women. 9.0, Interval. 10.40, News. 11.30, Song Records. 12 Noon, See Berlin (Funkstunde). 1.5 p.m., Popular Records. In the intervals, News. 2.30, Announcements; Records. 3.0, Exchange. 3.10, Poems (Friedrich). 3.20, Household Hints. 3.30, Programme for Children. 4.0, Concert by the Opera House Orchestra, Conductor: Kaestner. Overture, The Thieving Magpie (Rossini); Selection from Il Trovatore (Verdi); Three Swedish Dances (Graener); Overture, Le maçon (Auber); Kaiserwalzer (Joh. Strauss); Ballet Suite from Sylvia (Delibes); March (Carl). 5.30, Talk by an Explorer: The Bedouin. 5.50 (from Danzig), Talk for Parents. 6.15, Exchange. 6.25, Handwork for Boys. 6.55, Weather. 7.0, Hermann Löns Anniversary Programme. 7.30, Handel Organ Recital by Adolf Schütz, with Commentary. Overture, Lotharius; Chaconne in F; Echo Sonata; Aria; Trompetenstück; Concerto in G. 8.0, News. 8.10, See Frankfurt. 8.35, See Berlin (Funkstunde). 9.0, See Breslau. 9.10, Recital by Mia Neussitzer-Toennisson (Soprano). 10.20, News. 10.45, Dance Music. 12.30 a.m. (Thursday), Close Down.

KOSICE.—Relays Prague. **LAUSANNE**.—Relays Sottens.

LEIPZIG

785 kc/s, 382.2 metres; 120 kW. Relayed by Dresden, 1,285 kc/s, 233.5 metres.—5.50 a.m., Notes for Farmers. 6.0, Gym. 6.25, See Breslau. In the interval at 7.0, News. 8.0, Gym. 8.20, Records. 9.0, Interval. 9.40, Exchange. 9.45, Announcements. 10.10, See Hamburg. 11.0, Announcements; Records. 11.30, News; Time; Weather. 11.45, Notes for Farmers. 12 Noon, See Stuttgart. 1.0 p.m., News; Time. 1.10, Operetta Records. 2.0, News. 2.15 to 2.45, Opera Records. 3.20, Review of Hermann Löns Books. 3.40, Exchange. 4.0, The Poet of the Moors—a Hermann Löns Sequence with Music by a School Choir and Orchestra (Rasche). 4.45 (from Dresden), Recital by Rosl Müller (Violin), Gertrud Seydewitz (Mezzo-soprano), and Richter-Haaser (Pianoforte). 5.15, Harvest Thanksgiving Preparations—Report. 5.30, Talk: Leopold von Ranke, the Historian. 5.50, Exchange; Weather. 6.0, Variety Programme. 7.0, Beware of the Bend—a Safety First Play for Motorists (Schwerla). 8.0, News. 8.10, Talk: The Spirit of Weimar. 8.35, See Berlin (Funkstunde). 9.0, An Evening in Old Vienna—Concert by the Leipzig Symphony Orchestra. Conductor: Blumer. Soloists: Johanna Barklin (Soprano) and Erik Wirt (Tenor). Overture, Die Fledermaus (Joh. Strauss); Duet from Der Bettelstudent (Millöcker); March from Boccaccio (Suppé); Waltz from Der Vizeadmiral (Millöcker); O Herrgott, hast du dein Wien nimmer gesehn (Thoms); Moulinet-Polka (Jos. Strauss); Song from The Queen's Kerchief (Joh. Strauss); Wien wird schön erst bei Nacht (Stolz); Wien bleibt Wien (Schrammell); In Wien gibt's manch' witziges Gassel (Stolz); Song from The Bird Fancier (Zeller); Gallop, Gross-Städtisch (Ziehler); Song from Wiener Blut (Joh. Strauss); New Viennese Folk Music (Korn-

zak). 10.20, News. 10.50 (from Dresden), Concert by the Dresden Soloists' Ensemble: Overture, Fahrend Volk (Lenschner); Three Lyric Pieces (Keller); Wanderer-Suite (Knümann); Gondoliera (Ries); Frühlingszeit (Brekker); Ich liebe dich (Grieg); March, Malenkinder (Siede); Selection from Liselott (Künneke). 12 Midnight, Close Down.

LINZ.—Relays Vienna.

LUXEMBOURG

230 kc/s, 1,304 metres; 150 kW.—7.45 a.m., Records. 8.0, News in French; Record; News in German; Record. 12 Noon, Concert by the Station Orchestra; Conductor, Pensis: Overture (Strauwen); Grieg Potpourri (Ubach); Waltz (Konzak). 12.30 p.m., News in French and German. 12.40, Concert (contd.): Suite de Carnaval (Schmalstich). 1.0, Exchange. 1.5, Concert (contd.): Selection from The Land of Smiles (Lehár). 1.15, Records. 1.30, Exchange. 1.35, Records. 2.0, Exchange. 3.45, Exchange. 6.30, Concert of Light Music and Dance Music. 7.30, Racing Results. 7.35 till Close Down, Spanish Evening. 7.35, Accordion Recital by Marc Braum. 8.0, News in French and German. 8.20, Concert of Spanish Music by the Station Orchestra; Conductor, Pensis: Overture, El Guarany (Gomez). 8.30, Exchange. 8.35, Concert (contd.): Waltz, El Turia (Granados); Romance andalousa (Sarasate); Dances Nos. 5 and 6 (Granados); Spanish Suite (Albeniz); Record. 9.10, Concert of Spanish Music by Foreign Composers, by the Station Orchestra; Conductor, Pensis: Spanish Dances (Moszkowski); Record. 9.30, Sonata in B minor (Liszt) by René Delporte (Pianoforte); Record. 9.50, Concert (contd.): Pièce en Forme de Habanera (Ravel); Suite from Le Cid (Massenet); Andalousa (Rubenstein); Rhapsody Española (Chabrier); Caprice espagnol (Rimsky-Korsakov). 10.40, Dance Records.

MADRID

EAJ7, 1,095 kc/s, 274 metres; 7 kW.—9.0 a.m., News. 10.0, Announcements; Exchange. 10.30, Interval. 2.0 p.m., Chimes; Time; Weather; Popular Music; Talk. 2.30, Sextet Concert. 3.0, Amusement Guide; Exchange; Light Music. 3.30, Sextet Concert. 4.0, News; Popular Music. 4.30, Sextet Concert. 4.50, Film Review; News. 5.0, Interval. 6.0, Chimes; Light Music. 7.0, Announcement; Military Band Concert. 7.30, Exchange; Argentine Songs. 8.0, News. 8.15, Concert. Part I, Cello Recital: Andante (Bach-Silotti); Serenade (Schubert); Minuet (Mozart); Song (Dvorák); The Flight of the Humble Bee (Rimsky-Korsakov); Intermezzo, Goyescas (Granados); Minuet (Debussy); Granada (Ros); Bolero (Rubio). Part II, Orchestral Concert of Spanish Music. Part III, Song Recital: Arias from Samson and Delilah (Saint-Saëns), Mignon (Thomas), El palo moruno (Falla), Seguidilla murciana (Falla); Lullaby (Falla); Polo (Falla); Tirana (Nin); Aria from The Barber of Seville (Rossini). Part IV, Violin Recital: Partita in G minor (Bach); Romance in F (Beethoven); To Spring (Grieg); Caprice (Elgar); Orientale (Cui); Introduction and Tarantella (Sarasate). 9.40, Sports Notes. 10.0, Chimes; Time; Announcements. 11.0, News. 11.15, Concert by the Station Sextet. Soloist: Carmen Bonet (Mezzo-soprano). In the Interval, Programme by Ramón Gómez de la Serna. 12.45 a.m. (Thursday), News. 1.0, Chimes; Close Down.

MALMO.—Relays Stockholm.

MILAN

814 kc/s, 368.6 metres; 50 kW. Relayed by Turin, 1,140 kc/s, 263.2 metres; Genoa, 986 kc/s, 304.3 metres; and Florence, 610 kc/s, 491.8 metres.—7.30 a.m., Gym. 7.45, Time; News. 11.30, Concert by the Ferruzzi Orchestra. 12.30 p.m., Records. 12.45, News. 1.0, Time; Announcements. 1.5, Concert by the Chesi-Zarandelli-Cassone Trio. In the interval at 1.30, Records; Exchange. 2.15 to 2.25, Exchange. 4.35, News. 4.45, Programme for Children. 5.10, Concert of Chamber Music. 5.55, Weather. 6.0 to 6.10, Corn Prices. 7.0, News. 7.15, News in Foreign Languages. 8.0, Time; Announcements; Records. 8.30, Government Notes. 8.45, Comedy, Pirandello. 9.0, Concert by the Symphony Orchestra; Conductor, Guarneri. In the interval, Talk. 11.0 (approx.), News.

MONTE CENERI

1,167 kc/s, 257.1 metres; 15 kW.—12 Noon, News. 12.5 p.m., Concert by the Radio Orchestra: Overture, Orpheus and Eurydice (Gluck); Suite, Esquisses Bandades (Brusselsmans); Barcarolle (Grünfeld); Sottiquay (Gabriel-Marie). 12.29, Time; Weather. 12.33, Orchestral Concert (contd.); Selection from La Bohème (Fueick); Lullaby (Kricka); Sword Dance (Poldini). 12.55, News. 1.5, Records. 1.15, Fashion Talk. 1.30, Interval. 3.59, Time. 4.0 to 6.0, See Beromünster. 7.45, News. 8.0, Talk for Farmers. 8.15, Concert by the Radio Orchestra; Conductor, Leopoldo Casella: Overture, Sotomisa (Paër); Petite Suite (Debussy); Prelude and Clair de lune from Werther (Massenet); Dance of the Waves from Loreley (Catalani); Suite campestre (Amadei). 9.0, No Reply from LZ38—Comedy (Martin Kost). 10.0 (approx.), Close Down.

SEPT. 26th **WEDNESDAY** continued

MORAVSKA-OSTRAVA

1.158 kc/s, 259.1 metres; 11.2 kW.—6.0 to 7.15 a.m., See Prague. 9.50, See Prague. 10.15, Concert by the State Police Band; Conductor, Sochor. 11.0, Record. 11.5, See Bratislava. 11.55, See Prague. 12 Noon, Literary Programme. 12.10 p.m., See Prague. 12.30, Concert by the Station Orchestra; Conductor, Mussi. 1.20, Records. 1.30, See Prague. 1.40 to 2.0, Records. 3.15 to 4.20, See Prague. 5.40, Talk on Art. 5.59, Record. 5.55, News. 6.0, Talk. 6.10, Talk for Workers. 6.20, Pianoforte Recital by Alfred Rotter. 6.45, Records. 6.55, See Prague. 7.35, Reading. 7.50, Sketch (Röslor). 8.15, See Prague. 10.45, Records. 11.0 (approx.), Close Down.

MOSCOW (No. 1)

174 kc/s, 1.724 metres; 500 kW.—5.0 a.m., News. 5.15, Fanfare. 5.45, Gym. 6.15, Musical Programme. 8.15, Programme for Children. 9.0, Musical Programme. 9.58, Time. 10.0, News. 10.15, Concert for Collectivist Farmers. 3.0 p.m., Programme Announcements. 3.15, Programme for Children. In the interval, at 4.0, News. 5.30, Red Army Programme—Reading. 6.30, Literary and Musical Programme for Collectivist Farmers. 8.0, Play (Kornaitchouk), with Incidental Music by Kobalevsky. 9.0, Talk in Czech: The Harvest. 9.55, Chimes. 10.5, Talk in English: The Changing Face of Russia. 11.5, Talk in German: Towns of the Soviet Union.

MOTALA.—Relays Stockholm. MUHLACKER.—See Stuttgart.

MUNICH

740 kc/s, 405.4 metres; 100 kW. Relayed by Augsburg and Nürnberg, 1.267 kc/s, 236.8 metres.—6.30 a.m., Gym. 6.45, Motto. 6.50, Italian Lesson. 7.15, Time; News. 7.25, Concert of Schrammel Music. 9.50, Gym. for Women. 10.10, Hermann Löns Anniversary Programme for Schools. 10.55, Market Prices. 11.5, Notes for Farmers. 11.15, Time; News. 11.30, Announcements; Records. 12 Noon, Concert by the Munich Symphony Orchestra; Conductor, Ebner. 1.15 p.m., Time; News. 1.25, Popular Records. 2.0, News. 2.20 (from Nürnberg), Klavier-Skizzen, Op. 26 (Kilcher), by Karl Leonhard. 2.50, Talk: Spanish Gardens. 3.10, Pianoforte Lesson. 3.30 (from Nürnberg), Talk: Hermann Löns. 3.50, Announcements. 4.0, Variety Programme by the Schneider Orchestra and Soloists. 5.30, Programme for Children. 5.50, Sonata, Op. 31, No. 2 (Beethoven), by Ann Dimpler (Pianoforte). 6.10, Old Danzig—Sequence for Young People (Paris). 6.50, Time; Announcements. 7.0, See Breslau. 8.0, News. 8.5, An Imaginary Conversation with Goethe and the Goethe Lieder. 8.35, See Berlin (Funkstunde). 9.0, A Trifle too Exotic—German Composers' Conceptions of Music from Foreign Lands—versus the Reality; The Station Orchestra; Conductor, Kloss; Humorous Commentary by Hans Reimann; Real Records from Strange Lands. 10.0, Time; News; Exchange. 10.20, Josef Renner Recital by Haase (Baritone). 10.55, Wenker (Violin), and Schoedel (Organ). 11.0, Dance Music by the Station Band; Conductor, Aulich.

NAPLES.—Relays Rome. NOTODDEN.—Relays Oslo.

OSLO

250 kc/s, 1.154 metres; 60 kW. Relayed by Hamar, 519 kc/s, 573 metres, and Joloy, 6.990 kc/s, 42.92 metres.—11.15 a.m., Service. 11.50, Exchange. 12.55 p.m., Nauen Time Signal. 1.0 to 2.0, Records. In the intervals at 1.15, Weather; Talk for Farmers; and at 1.45, Exchange. 5.0, Records. 6.0 till Close Down, Programme to be announced.

OSTERSUND.—Relays Stockholm.

PARIS

POSTE PARISIEN, 959 kc/s, 312.8 metres; 100 kW.—7.10 a.m., Fanfare; Records. In the interval at 7.30, News. 8.5, Concert. 8.20, News. 8.45, Cookery Talk. 12 Noon, Exchange. 12.5 p.m., Operetta Records. 12.25, News. 12.35, Records. 12.45, Dance Music by the Station Jazz Band and a Vocal Trio; Soloist, Carol King. In the intervals at 1.5 and 1.30, Exchange. 2.0, Exchange. 3.15, Exchange. 3.45, Exchange. 4.50, Exchange. 6.25, Jewish Programme. 6.45, Exchange. 6.49, Wagner Records: Entry of the Gods in Valhalla from The Rhinegold; Extracts from Siegfried. 7.10, News. 7.30, News. 7.45, Records. 8.0, Interval. 8.10, Pianoforte Recital by Yolande Kornhold. 8.30, The Sacred Flame—Play in Three Acts (Somerset Maugham). In the intervals, Exchange; Talk. 10.20, News. 10.30 till Close Down, Programme in English arranged by the International Broadcasting Company of London. 10.30, Around the Shops. 11.0, I.B.C. Good-night Melody and Close Down.

PARIS

RADIO PARIS, 182 kc/s, 1.648 metres; 75 kW.—6.45 a.m., Gym. 7.0, Records. 7.15, News. 7.45, Gym. 8.0, Records. 12 Noon, Talk: Education. 12.15 p.m., Dance Music by the Lucien Goldy Band; Soloist, Jean Sorbier (Song Refrains). In the interval at 1.20, Exchange. 3.45, Exchange. 6.20, Weather; Notes for Farmers; Talk; Ex-

change; Racing Results. 6.45, Medical Talk. 7.0, Talk. 7.15, British Press Review. 7.30, Topical Talk. 8.0, Readings by Paul Reboux. 8.30, News. 8.45, Records. 8.55, Concert from Vienna. 10.0, Song Recital by Sobrier and Henriette Lebard. 10.30, Dance Music by Atkins' Band.

PITTSBURGH

KDKA, 980 kc/s, 306 metres; 50 kW. Relayed by W3XK, on 48.86 metres; and 25.27 metres.—3.0 p.m., Harvest of Song. 3.15, Sammy Fuller. 3.30, To-day's Children. 3.45, News; Cookery Hints. 4.0, Uncle Tom and Betty. 4.15, Tony Wons. 4.30, United States Army Band. 5.0, Fields and Hall. 5.15, Charles Sears (Tenor). 5.30, Vic and Sade. 5.45, Hotel William Penn Orchestra. 6.0, Exchange. 6.15, Honourable Archie and Frank. 6.30, Farm and Home Hour. 7.30, KDKA Home Forum. 8.0, Don Carlos and his Orchestra. 8.15, Harry Kogen's Orchestra. 8.45, Human Values. 9.0, Betty and Bob. 9.15, Karen Fladdos. 9.30, Exchange. 9.45, Chicago Symphony Orchestra. 10.15, KDKA Kiddies' Klub. 10.30, The Singing Lady. 10.45, Orphan Annie. 11.0, Dan and Sylvia. 11.14, Baseball Résumé. 11.30, Comedy Stars of Hollywood. 11.45, Lowell Thomas. 12 Midnight, Amos 'n' Andy. 12.15 a.m. (Thursday), Johnny Johnson's Orchestra. 12.30, Irene Rich. 12.45, Music; News; Drama. 1.0 to 6.0 a.m., Popular Programme.

PORSGRUND.—Relays Oslo.

PRAGUE

638 kc/s, 470.2 metres; 120 kW.—6.0 a.m., Time; Gym; Music; News. 7.15, Interval. 9.50, News. 10.5, News in German. 10.10, Record. 10.15, See Moravská-Ostrava. 11.0, Record. 11.15, See Bratislava. 11.55, Notes for Farmers. 12 Noon, Time; Talk for Farmers. 12.10, Records. 12.20, News. 12.30, See Moravská-Ostrava. 1.20, Talk for Brain Workers. 1.30, Labour Market. 1.40, Labour Market in German. 1.50, Exchange. 1.55, Exchange and Weather in German. 2.0, Interval. 3.15, Concert by the National Guards' Band; Conductor, Labsky. 4.15 to 4.20, Exchange; Weather. 5.30, Talk for Workers. 5.40, Talk: Light and Classical Music. 5.50, Talk for Farmers. 6.0, Announcements. 6.5, Record. 6.10, Talk for Workers. 6.20, German Transmission: Topical Talk; Talk for Workers; News. 6.55, News in German. 7.0, Time; News. 7.10, Concert of Schrammel Music. 7.35, Talk. 7.50, Song Recital by Pia Igy. 8.15, Talk: Denmark's National Holiday. 8.25, Queen Dagmar's Land—Radio Picture. 9.0, Concert for Arnold Schönberg's Sixtieth Birthday; The Station Orchestra; Conductor, Jirák: The Kolisch Quartet; Soloists, Julie Nussy-Bácherová (Songs); Concerto grosso in A, Op. 6 (Schönberg-Handel); String Quartet No. 2 in F sharp minor with Soprano Solo (Schönberg). 10.0, Time; News. 10.15, Records. 10.45, News in French. 11.0 (approx.), Close Down.

RJUKAN.—Relays Oslo.

ROME

Call 190, 713 kc/s, 420.8 metres; 50 kW. Relayed by Naples, 1.104 kc/s, 271.7 metres; Milan No. 2, 1.348 kc/s, 222.6 metres; Turin No. 2, 1.357 kc/s, 221.1 metres; and RRO, 11.810 kc/s, 25.4 metres.—7.30 a.m., Gym. 7.45, Time; Announcements. 8.0, Interval. 12.30 p.m., Records. 1.5, Concert of Light Music. In the interval at 1.30, Time; News. 2.15, Interval. 4.30, Programme for Children. 4.55, News; Exchange. 5.10, See Milan. 5.55, Weather. 6.0 to 6.10, Corn Prices. 7.0, News; Report of the Royal Geographical Society. 7.15, News in Foreign Languages. 8.0, Time; News. 8.10, Records. 8.30, Government Notes. 8.45, The Love of the Three Kings (Montemezzi). 11.0, News.

RUYSSELEDE

10.330 kc/s, 29.04 metres; 8 kW.—7.45 p.m., News in French. 8.0, See Brussels No. 1. 9.0, News in Flemish. 9.15, Close Down.

SALZBURG.—Relays Vienna.

SCHENECTADY

WGY, 790 kc/s, 379.5 metres; 50 kW. Relayed at intervals by W2XAF, on 31.48 metres; and W2XAD on 19.56 metres.—7.0 p.m., Dreams Come True; Barry McKinley (Songs). 7.15, The Wise Man—Dramatic Programme. 7.30, Woman's Radio Review; Talks; Orchestra. 11.25, Exchange. 12 Midnight, Guest Artists and Instrumental Quartet. 1.0 to 3.0 a.m. (Thursday), Popular Programme.

SOTTENS

677 kc/s, 443.1 metres; 25 kW.: and Geneva, 401 kc/s, 748 metres.—7.0 to 7.15 a.m., Gym. 12.29 p.m., Time; News. 12.40 (from Geneva), Records. In the interval at 1.0, Exchange. 2.0, Interval. 3.59, Time. 4.0, See Beromünster. 6.0 (from Geneva), Programme for Women. 6.35 (from Geneva), Esperanto Lesson. 6.40 (from Geneva), Opera Records. 6.50 (from Geneva), Chess Lesson. 7.10 (from Geneva), Geography Talk. 7.40 (from

Geneva), Wireless Notes. 7.59, Weather. 8.0 (from Geneva), Songs of the Mountains—Lecture-Recital; A Double Vocal Quartet; Conductor, Schenk: Le ruisseau (Bovet); Souvenir lointain (Schneberger); Sur l'alpe voisine (Daleroze); Le flot et le vent (Bovet); Chants montagnards (Mouton); Les cloches du soir (Weyts). 9.15, News. 9.25 (from Geneva), Concert of Light Music by the Geneva Municipal Orchestra; Conductor, Gabelles; Soloist, Dupont (Cornet). 10.0 (from Geneva), Talk: The Work of the League of Nations. 10.15 (approx.), Close Down.

STOCKHOLM

704 kc/s, 426.1 metres; 55 kW. Relayed by Boden and Östersund, 413.5 kc/s, 726 metres; Göteborg, 941 kc/s, 318.8 metres; Hörby, 1.131 kc/s, 265.3 metres; Motala, 216 kc/s, 1.389 metres; and Sundsvall, 601 kc/s, 499.2 metres.—7.20 a.m., Gym. 7.45, Service. 8.0, Weather. 12.5 p.m., Gym. for Schools. 12.30, Weather. 12.55, Time. 1.0, Talk for Schools. 1.20, Orchestral Concert of Light Music, relayed from Malmö, 1.312 kc/s, 228.7 metres. 2.25, Talk. 2.45, Programme for Children. 3.0, Interval. 5.0, Weather. 5.5, Song Recital by Nonne Hall and Ericson-Bönick, relayed from Norrköping. 5.25, Reading (Janson). 5.45, Records. 6.45, Elementary German Lesson. 7.15, Weather; News. 7.30, Literary Review, relayed from Uppsala. 8.0, Bach Pianoforte Recital by Iso Elinson: Five Preludes and Fugues; The Italian Concerto. 8.40, A Report. 9.0, Cello Recital by Kinkulkin: Sonata in D minor (Corelli); Chanson triste (Kalinnikov-Kinkulkin); Grotesque (Haas); Harlequin (Popper). 9.20, Talk. 10.0, Dance Records. 11.0 (approx.), Close Down.

STRASBOURG

859 kc/s, 349.2 metres; 15 kW.—11.0 a.m., Concert relayed from Marseilles, 749 kc/s, 400.5 metres. 12 Noon, Orchestral Concert of Light Music; Conductor, Roskam: Slav Rhapsody (Volpatti); Waltz, Myotis (Albéniz); Selection from The Last Waltz (O. Strauss); Sing a little Low-down Tune (Tobias-Scholl-Menchner); Wedding Serenade (Klose); Don't say Good-night (Rubin-Warren); In the Kingdom of Buddha (Armandola); Down South (Myddleton); Aloha, Beloved (Long and Canfield); March, Angelina (Ricardo). 1.5 to 2.0 p.m., Records. 4.45, Talk in German: Electricity. 5.0, Concert relayed from Bordeaux-Lafayette. 6.0, Medical Talk. 6.15, Talk in German: The New Austrian Constitution. 6.30, Pierre Bretagne Concert; Jean Hazart (Songs), Roskam (Cello) and Pogoda (Pianoforte); Sonata in G for Cello and Pianoforte; Songs: Les Voex secrets; Pianoforte Solo, Petite Suite rustique; Songs: Images de mon pays. 7.30, Time; News. 7.45, Records. 8.0, News in German. 8.30, The Dollar Princess—Operetta in Three Acts (Fall); Conductor, de Villers. In the interval at 9.30, News. 11.0, Dance Music from the Caveau de l'Aubette. 12 Midnight (approx.), Close Down.

STUTTART

MUHLACKER, 574 kc/s, 522.6 metres; 100 kW.—5.35 a.m., Notes for Farmers. 5.45, Hymn; Time; Weather. 5.50, Gym. 6.15, Records. 6.40, Time; Announcements. 6.55, Records. 7.25, See Munich. 8.10, Weather. 8.15, Gym. 8.35 to 8.40, Announcements. 9.45, Talk for Mothers. 10.0, News. 10.10, Rentlingen—Sequence for Schools (Nothardt). 10.40, Talk: Influenza. 11.10, Chopin Recital by Gertrud Schaufele-Steingässer (Pianoforte); Waltz in A flat, Op. 34, No. 1; Waltz in A minor, Op. 34, No. 2. 11.25, Announcements; Records. 11.55, Weather. 12 Noon, Concert by the Station Orchestra. 1.0 p.m., News. 1.20, The Four Seasons—Concert on Records. 1.50, Time; News. 2.0, Folk Music Records. 2.30, Concert by the Hühnerfeld-Saar Choir. 3.0, Stories for Children. 3.15, Theodor Röhmayr and Lothar Windsperger Song Recital by Hilde Noller (Mezzo-Soprano). 3.45, Talk: Destructive Insects. 4.0, See Königsberg. 5.30, Legal Talk. 5.45, Readings (Essig). 6.10, Pianoforte, Viola and Flute Recital, relayed from Karlsruhe. 6.50, Swabian History Talk. 7.20, Accordion Concert. 7.45, Time; Weather; Notes for Farmers. 8.0, News. 8.10, Political Talk. 8.35, See Berlin (Funkstunde). 9.0, See Breslau. 10.0, Talk in Dialect, relayed from Karlsruhe: Karlsruhe's History. 10.20, Time; News. 10.35, Topical Talk. 10.45, News. 11.0, Dance Music by the Wende Band. 12 Midnight, Light Music. 1.0 a.m. (Thursday), Close Down.

SUNDSVALL.—Relays Stockholm.

TOULOUSE

913 kc/s, 328.6 metres; 10 kW.—8.0 a.m., Dance Refrains. 8.30, News. 8.35, Orchestral Music. 8.45, Songs. 12 Noon, Arias from Opera. 12.15 p.m., Light Music. 12.30, News; Exchange. 12.45, Request Music. 1.0, Market Prices. 1.5, Sound Film Music. 1.15, Light Orchestral Music. 1.30, Songs. 1.45, Military Band Music. 2.0, News.

6.0, News. 6.15, Light Music. 6.30, Chansonnets. 6.45, Opera Music: Selection from Rigoletto (Verdi); Prelude to Parsifal (Wagner); Prelude to Faust (Gounod). 7.0, Sound Film Music. 7.15, Hawaiian Guitar Solos. 7.30, News; Racing Results; Exchange. 7.45, Orchestral Music: Spanish Dance No. 6 (Granados); Marche militaire (Saint-Saëns). 7.50, Talk. 8.15, Medical Talk. 8.30, Duets. 9.0, Le Roman d'Amour—Radio Fantasy. 9.30, Military Band Music. 10.0, Au Caveau de Dix Heures—Radio Fantasy. 10.15, News. 10.30, Operetta Music: Selection from The Bayadere (Kálmán); La Mascotte (Andran); Les Vingt Huit Jours de Clairette (Roger-Tavari); Waltz from Die Teresina (O. Strauss). 11.0, Request Music. 11.15, Light Music. 11.30, Songs. 11.50, Baladaika Music and Russian Songs. 12 Midnight, News; Announcements. 12.5 a.m. (Thursday), Opera Music; Arias from Boris Godunov (Mussorgsky); The Valkyrie (Wagner) and Der Freischütz (Weber). 12.15 a.m., Orchestral Music: Academic Festival Overture (Brahms); Selection from Idomeno (Mozart). 12.30, Close Down.

TRONDHEIM.—Relays Oslo. TURIN.—Relays Milan.

VATICAN CITY

15.120 kc/s, 19.84 metres, 10 kW. (Morning), 5.970 kc/s, 50.26 metres (Evening).—11.0 to 11.15 a.m., Religious Information in Spanish. 8.0 to 8.15 p.m., Religious Information in Italian.

VIENNA

592 kc/s, 506.8 metres; 120 kW. Relayed by Graz, 886 kc/s, 338.6 metres; Innsbruck, 519 kc/s, 578 metres; Klagenfurt, Linz, and Salzburg, 1.294 kc/s, 231.8 metres.—9.0 a.m., News. 9.20, Market Prices. 9.30, Weather. 10.50, Water Level Report. 11.30, Programme for Women. 11.55, Weather. 12 Noon, Popular Records. 1.0 p.m., Time; News. 1.10, Popular Records. 2.0, Announcements. 2.10 to 2.30, Records of Famous Artists. 3.30, Time; Announcements. 3.50, Programme for Children. 4.10, News. 4.15, Handwork Programme. 4.30, Sound Film Records. 5.30, Recital of Contemporary Austrian Music by Frieda Müller (Soprano) and Jenő Takács (Pianoforte): Songs (Mojsisovics): (a) Ein Traum, (b) Am Stieckhansen, (c) Die Georgine, (d) Waldlied; Pianoforte Solos (Jenő Takács): (a) Seventeen Miniatures from the Philippines, (b) Three Bagatelles. 6.0, Talk. 6.25, Talk: The Eighth World Congress of Philosophers at Prague. 6.50, Topical Talk. 7.0, Time; News. 7.20, Dance Music by the Fox Jazz Band and Roland (Song Refrain). 8.5, Concert by the Vienna Symphony Orchestra, relayed from the Konzerthausaal; Conductor, Kabasta; Soloist, Enid Szanthe (Contralto): Symphonic Variations on an Old German Dance Song (Robert Wagner); Five Songs (Rinaldini); Symphony No. 2 in C Minor (Bittner). 10.0, Orchestral Concert: March (Dostal); Waltz, Gold and Silver (Lehár); Overture, Marianne (Pucik); Romance and Waltz Intermezzo (Hies); Selection from Faust (Gounod); Overture, Der Schatzmeister (Ziehrer); Wine, Woman and Song (Joh. Strauss); Potpourri, Fortissimo (Kálmán); Potpourri, Streiflichter (Morena); March Refrain, Frühjahrsparade (Stolz). 12 Midnight, Dance Records. 1.0 a.m. (Thursday), Close Down.

WARSAW

223 kc/s, 1.345 metres; 120 kW.—6.45 a.m., Hymn. 6.48, Records. 6.58, Gym. 7.8, Records. 7.15, News. 7.25, Records. 7.35, Hint for Housewives. 7.40, Programme Announcements. 7.50, Announcements; Light Music. 8.0, Interval. 11.57, Time. 12 Noon, Fanfare from St. Mary's Church, Cracow. 12.13 p.m., Weather. 12.5, Press Review. 12.10, Orchestral Concert from Cracow, 986 kc/s (304.3 metres). 1.0, News. 1.5, Ketyber Records. 1.30, Interval. 3.30, Announcements. 3.35, Exchange. 3.45, Dramatic Programme. 4.0, Talk with Illustrations: The Waltz. 4.45, Talk for Children. 5.0, Song Recital by Zmigród-Fedyczkowska. 5.25, Dialogue for Women: Mother and Daughter. 5.35, Records. 5.50, Sports Notes. 6.0, Programme for Farmers. 6.10, Art Notes. 6.15, Violin and Pianoforte Recital by Olechowski and Rosenbaum: Sonata in A Minor (Veracini); Pieces (Reger): (a) Wiegendorf, (b) Capriccio, (c) Minuet; Lyric Poem, Op. 7 (Tcherepnin). 6.45, Talk: The Economic Development of the North-Eastern Countries. 7.0, Light Music from the Adria Café. In the interval at 7.20, Topical Talk. 7.45, Programme Announcements. 7.50, Sports Notes. 8.45, Records: The Squire Celeste Octet. 8.5, News. 8.55, Talks. 9.0, Chopin Pianoforte Recital by Drzewiecki. 9.30, Talk. 9.40, Danish National Festival Programme: Concert of Danish Music by the Station Symphony Orchestra; Conductor, Grøndahl; Soloist: Einar Nørby (Songs); Address by the Danish Minister; Danish and Polish National Anthems; Solemn Overture in C (Peder Gram); Aria from Eliza (Kuhlau); Aria from Mascerade (Nielsen); Symphony No. 1 in G Minor, Op. 7 (Nielsen); Song No. 1 (Hjese); Aria from the Jutland Cantata (Hjese-Knudsen); Overture (Benzton). In the intervals at 10.0, Announcements; Light Music, and at 11.0, Weather. 11.30, Dance Music from the Oaza.

ZURICH.—Relays Beromünster.

ATHLONE

565 kc/s, 531 metres; 60 kW. Relayed by Dublin, 1,348 kc/s, 222.6 metres; and Cork, 1,240 kc/s, 241.9 metres.—1.30 to 2.30 p.m., Time Signal; Exchange; Weather; Records; 4.0, Concert by the Garda Síochána Band...

BARCELONA

795 kc/s, 377.4 metres; 15 kW.—8.15 a.m., News; Records, 9.0, Chimes; Gym; Records, 9.20, News; Records, 10.0, Obituary, 12 Noon, Chimes; Weather, 1.0 p.m., Programme for Women, 1.45, Records, 2.0, Records, 2.30, Theatre Notes; Amusement Guide; Records, 3.0, News; Film Talk; Sextet Concert; Exchange, 4.0, Programme for Hospitals, 5.0, News, 7.0, Concert by the Station Trio...

BASEL.—Relays Beromünster.

BELGRADE

686 kc/s, 437.3 metres; 2.5 kW.—10.45, Programme Announcements, 10.50, Titles, 11.0, Records, 11.30, Military Band Concert, 11.59, Chimes, 12.5 p.m., Military Band Concert, 12.45, Exchange; Announcements, 1.10, Military Band Concert (contd.), 1.30, News; Time, 4.0, Programme for Schools, 5.0, Records, 6.55, Time; Programme Announcements, 7.0, Records, 7.10, Talk, 7.30, Announcements, 7.40, Records, 8.0, Talk, 8.30, Clarinet Recital, 9.0, Arias and Duets from Manon (Massenet) and Faust (Gounod)...

BERLIN

DEUTSCHLANDSENDER, 191 kc/s, 1,571 metres; 60 kW.—5.45 a.m., Weather; News, 6.0, Gym, 6.15, Motto, 6.20, See Berlin (Funkstunde). In the interval at 7.0, News, 8.0, Interval, 8.45, Gym, for Women, 9.0, Talk on Records; Economic Conditions in New York, 9.40, Domestic Science, 10.0, News, 10.10, Old German Dances, Introductory Talk and Commentary by Rützel, 10.50, Physical Training, 11.15, Weather, 11.30, Talk; Bee-keeping, 11.55, Weather, 12 Noon, See Cologne, 12.55 p.m., Time, 1.0, Records of Zither Music; Weather, 1.45, News, 2.0, Interval, 2.45, Greetings; Announcements, 3.0, Weather; Exchange, 3.15, Animal Voices—Guessing Competition for Children (on Records), 3.40, Julius Patzak sings Viennese Songs (on Records), 4.0, See Leipzig, 5.40, Heinrich Zöllner reads from his own works, 6.0, Northern Folk Song—Recital by the Station Solo Quartet, 6.30, York von Wartenberg Memorial Programme, 6.55, Poem; Weather, 7.0, A Century's German Music—Concert by the Small Station Orchestra, Conductor, Hess, Overture, Iphigénie en Aulide (Glück); Minuet from the Military Symphony (Haydn); Overture, Figaro (Mozart); Larghetto from Symphony No. 2 (Beethoven); Overture, Preciosa (Weber); Entr'acte from Rosamunde (Schubert); Radetzky March (Joh. Strauss), 8.0, Motto; News, 8.15, Our Village—Hamburg, Königsberg, Frankfurt, Stuttgart and Munich Inter-Relay Programme. (For details see Munich), 10.0, News; Sports and Art Notes, 10.25, Talk; Freikler vom Stein, 10.45, Weather, 11.0, Dance Music by the Casani Club Orchestra from London, 11.25, Concert of Cigany Music from Budapest, 12 Midnight, Close Down.

BERLIN

FUNKSTUNDE, 841 kc/s, 356.7 metres; 100 kW.—6.0 a.m., Hymn; Gym, 6.15, Weather; Meditation, 6.20, Concert by the Edvard Prasch Orchestra. In the interval at 7.0, News, 8.0, Gym, 8.20, Interval, 9.0, See Berlin (Deutschlandsender), 9.40, Interval, 9.45, Games for Children, 10.0, News; Market Prices, 10.30, Records; Announcements, 11.25, Exchange, 11.30, Interval, 12 Noon, Orchestral Concert from Königsberg. In the interval at 12.30 p.m., Weather, 1.0, News, 1.15, Records; Light Music, 2.0, News, 2.15, Extracts, Othello (Verdi) on Records, 3.0, Exchange, 3.20, Interval, 4.0, Orchestral Concert. In the interval: Travel Talk: Easter Island, 6.0, Announcements, 6.5, Back to the Land—Play for Young People

THURSDAY

SEPTEMBER THE TWENTY-SEVENTH

(Ulrich). 6.20, With the Microphone through the Berlin Docks, 7.0, Recital of Old German Folk Songs by the Station Choir; Conductor, Weigel; Drei Laub auf einer Linde; Gott hüthe dich (Lechner); Mit Fröhlichkeit (Johann Staden); Rundadimella (Schein); Ein Henlein weiss (Scandelli), 7.15, Recital of New Hungarian Music by Pál Kiss (Pianoforte); Lamentatio, Op. 11 (Kodály); Two Concert Studies (Dohányi); Suite, Op. 14 (Béla Bartók); Six Hungarian Folk Dances (Béla Bartók), 7.40, The Station Director discusses the Winter Programmes, 8.0, News, 8.10 to 1.0 a.m. (Friday), German, Polish, Hungarian, Swedish and English Inter-Relay Programme, 8.10, Dance Music by the Adalbert Lutter Band from the Wilhelmshalle, Berlin, 8.30, See Warsaw, 9.15, Concert from Budapest, 10.0, See Stockholm. In the interval at 10.20, News, 10.40, Inter-Relay Programme (contd.); Dance Music by the Casani Club Orchestra from London, 11.25, Cigany Music from Budapest, 12 Midnight, Dance Music by the Adalbert Lutter Band from the Wilhelmshalle, Berlin, 1.0 a.m. (Friday), Close Down.

BERNE.—Relays Beromünster.

BEROMUNSTER

556 kc/s, 539.6 metres; 60 kW.—12 Noon, Concert of the Nineteenth Century French Music by the Station Orchestra, 1.25 p.m., Time; Weather; Exchange, 3.30, Records; Light Music, 3.55, Time, 4.0, See Sottens, 6.0, Records, 6.30, Talk in Dialect, 7.0, Time; Weather; Traffic Notes, 7.5, Talk; The Work of the League of Nations, 7.25, Recital of Old French Songs by Marguerite Altzyer, 8.0, Talk: The Swiss Constitution, 8.30, Bach Pianoforte Music by Hermann Hans Wetzler, 9.0, Weather; News, 9.10, Vincent and Ganguin—Sequence (Börner), 10.10, Weekly Review for Swiss Abroad, 10.30 (approx.), Close Down.

BODEN.—Relays Stockholm. BODO.—Relays Oslo.

BRATISLAVA

1,004 kc/s, 298.8 metres; 13.5 kW.—6.0 to 7.15 a.m., See Prague, 9.45, Announcements, 9.50, See Prague; 10.0, News in Hungarian, 10.15, Records, 10.30, See Brno, 11.0, Water Level, 11.5, See Prague, 12 Noon, Talk for Farmers, 12.20 p.m., See Prague, 12.30, Concert by the Station Orchestra; Conductor, Schimpl, 1.30, See Prague, 1.40, News and Weather in German and Hungarian, 1.50, See Prague, 2.0 to 2.5, Exchange, 3.15 to 4.20, See Prague, 4.40, See Prague, 5.40, Talk; Young Slovakia, 5.50, Records, 6.0, Talk for Workers, 6.10, Talk for Housewives, 6.15, Hungarian Transmission; Educational Talk: A Slovak Tale, 6.55, See Prague, 10.45, News in Hungarian, 11.0, Close Down.

BREMEN.—Relays Hamburg.

BRESLAU

950 kc/s, 315.8 metres; 60 kW. Relayed by Gletwitz, 1,231 kc/s, 243.7 metres.—5.0 a.m., Song; Motto; Records. In the interval at 5.40, Weather, 6.0, Time; Weather; Gym, 6.25, See Cologne. In the interval at 7.0, Time; News, 8.0, Light Music on Records, 9.0, Time; News, 10.10 to 10.40, The Saar—Sequence for Schools (Reinicke), 11.30, Time; News, 11.45, Talk for Farmers, 12 Noon, Orchestral Concert, Conductor, Kadon, March (Weigl); Overture, Marco Spada (Auber); Orchestral Suite (Joun); Hungarian Rhapsody No. 13 (Liszt); Waltz (Joh. Strauss); Overture, Le roi Lear (Debussy); Polish March (Leopold); Sinfonietta for Strings (Haydn); Selection from La Traviata (Verdi-Schremer); Silsian Dances (Müller); Capriccio for Flute and Orchestra (Kempfer); Ein Sommerabend am Rhein (Zimmer). In the interval at 12.30 p.m., Weather; and at 1.30, Time; News, 2.20, Exchange, 2.25, Announcements; Records, 2.50, Market Prices, 3.10, Pianoforte Recital by Charlotte Bretschneider; Aufschwung (Schumann); Ecce salses (Beethoven); Variations in E-flat (Beethoven), 3.40, Humorous Play for Children (Colbert), 4.0, Concert of Festival Music by the Station Orchestra, Conductor, Rischka, Suite from Baechetto musicale (Schein); Intrada I and II (Hassler); Air (Bach); Fische-Lied Overture in B-flat (Handel); Fenschersmusik (Handel); Ballet Suite No. 2 (Glück); Two Minnets (Haydn); Overture, Figaro (Mozart); Triumphant March from Tarpaja (Beethoven), 5.30, Announcements, 5.35 (from Gletwitz), Talk for Mothers, 5.55, Reading (Schönberg), 6.25, Reading (Grait-eh), 6.50, Announcements, 7.0, Homann Lons—Literary Sequence (Kauppel), with Songs by Gerda Specht (Mezzo-Soprano) and Kurt Blume (Tenor), 8.0, News, 8.10, Reading (Wagenführer), 8.30, Lull Close Down, Polish, Hungarian, Swedish and English Inter-Relay Programme, 8.30, See Warsaw, 9.15, Concert

from Budapest, 10.0, See Stockholm, 10.20, Interval; Time; News, 10.40, Inter-Relay Programme (contd.), 10.40, Dance Music relayed from London, 11.25, Cigany Music relayed from Budapest, 12 Midnight, Close Down.

BRNO

922 kc/s, 325.4 metres; 32 kW.—6.0 to 7.15 a.m., See Prague, 9.50, See Prague, 10.30, Programme for Schools, 11.0, See Prague, 12.30 p.m., See Bratislava, 1.30, See Prague, 2.0 to 2.10, Labour Exchange in German, 3.15 to 4.20, See Prague, 4.40, See Prague, 5.40, Hints for Housewives, 5.45, Talk: The Society Woman, 5.55, Records, 6.10, Theatre and Film Notes, 6.20, Two Talks in German, 6.55, See Prague, 7.35, Reading, 7.50, Record, 7.55, See Prague, 11.0 (approx.), Close Down.

BRUSSELS (No. 1)

620 kc/s, 483.9 metres; 15 kW.—11.55 a.m., Weather, 12 Noon, Popular Records, 1.0, p.m., News, 1.10, Orchestral Concert: March (Weylts); Selection from La petite mariée (Lecocq); Cortège oriental (Leemans); Sornettes (De Taeze); Petite Suite (Kalkman); Tarantella (Caludi); March Potourri (Voitschach), 2.0, Interval, 4.55, News, 5.0, Operetta Records, 5.30, Programme for Children, 6.0, Talk, 6.15, Orchestral Concert: Piece (Noack); In the Jungle (Brussehans); Russian Melodies (Higgs); Violin and Pianoforte: Two Spanish Dances (Sarasate); Selection from Fatinitza (Suppé); Interlude by Requilié; Scherzo (Depröz); Selection from Hans the Flute Player (Ganne), 7.15, Talk for Workers, 7.30, Sports Notes; Colonial Review, 8.0, Concert by the Symphony Orchestra; Soloist: Duxyk (Violini); Selection from Le tableau parlant (Grétry); Violin Concerto (Mozart); Ballet Air from Orchestral Pieces (Sacchini-Govaert); First Suite from Nannanna (Lalo); Concerto grosso, No. 11 (Corelli), 9.0, Talk; Communal Finance, 9.15, Concert by the Symphony Orchestra; Overture, The Siege of Corinth (Rossini); Ballet Music from William Tell (Rossini); Interlude: Programme by The Renaudins; Selection from Thaïs (Massenet); Petite Suite (Henri Büsser), 10.0, News, 10.10, Request Records, 11.0 (approx.), Close Down.

BRUSSELS (No. 2)

932 kc/s, 321.9 metres; 15 kW.—Programme in Flemish, 11.57 a.m., Weather, 12 Noon, Popular Orchestral Music: Love Song (Toselli); Malagena (Moszkovsky); The man I love (Gershwin); Marrakesch (Percy); Paysages (Doullez); Rondo français (Boëllmann); Moorish Song (Turina); The Angels' Sérénade (Braga); Autfois (Sibelius); Song from The Merry Widow (Lehár); Russian Melody (Akinenko); Cloches du soir (Saint-Saëns), 1.0 p.m., News, 1.10, Selection from Il Trovatore (Verdi) on Records, 2.0, Interval, 4.55, Announcements, 5.0, Concert by the Symphony Orchestra; Romantic Overture (Kéler-Béla); Oehsemennett (Haydn); Valse lente (Chopin); Danse (Debussy); Joyeuse marche (Chabrier), 5.45, Programme for Children, 6.30, Programme for Young People, 7.15, Talk, 7.30, Tourist Report, 8.0, Extracts from The Barber of Seville (Karel Albert) by the Radio Orchestra. In the interval at 8.45, Roman Catholic Address, 9.50, Prayers, 10.0, News, 10.10, Records, 11.0, Close Down.

BUDAPEST

546 kc/s, 549.5 metres; 120 kW.—6.45 a.m., Gym, 9.45, News, 10.0, Two Talks, 12 Noon, Chimes from the University Church, 12.5 p.m., Concert by the Szimrino Balalaika Orchestra, 1.30, Police Band Concert, 2.40, Household Hints, 4.0, Fairy Tales, 5.0, Talk for Farmers, 5.30, Concert of Light Music by the Bertha Orchestra, 6.20, English Lesson, 6.50, Talk for the Fiftieth Anniversary of the Opera House, 7.25, Gala Programme relayed from the Opera House, 10.45, Concert by the Csorba Cigany Band, relayed from the Britannia Hotel.

CASSEL.—Relays Frankfurt.

COLOGNE

658 kc/s, 455.9 metres; 60 kW.—5.30 a.m., Hymn; Records, 6.5, Gym, 6.25, Concert by the Düsseldorf Concert Orchestra, from the Bach-Saal, Düsseldorf. In the interval from 6.50 to 7.5, Hymn; News, 8.0, Weather; Water Level, 8.5, Gym, for Women, 8.20, Cookery, 8.30, Interval, 10.0, News, 10.10, Topical Talk, 11.10, Military Talk, 11.30, Records; Announcements, 12 Noon, Concert by the West German Chamber Orchestra; Conductor, Hartmann; Overture, The Nalads (Benett); Aquarellen-Walzer (Strauss); Selection from La

Favorita (Donizetti); Nocturne (Liszt); Ein Fest im Gnomereich (Witteborne); Durch Webers Zaubermag (Urbach); Salut d'amour (Elgar); Ständchen (Widor); Waltz, Abendsterne (Lanner); Rhapsody No. 6 (Liszt). In the interval at 12.45 p.m., News; Greetings, 1.45, News, 2.0, Humour and Light Music on Records, 3.0, Industrial Talk, 3.15, Talk by a State Railway Superintendent, 3.30, Exchange, 3.50, Topical Talk, 4.0, Concert by the Station Orchestra; Conductor, Kühn; Soloist, Margot Gripekoven (Soprano); Overture, Ein tolles Mädel (Ziehrer); Song from The Gipsy Baron (Strauss); Waltz from Der Kellermeister (Zeller); Extracts from Das Pensionat (Suppé); Czardas from Die Fledermaus (Strauss); Selection from Der Obersteiger (Zeller); Waltz, Alt-Wien (Kremsner), 5.0, Science Talk, 5.20, Song Recital by Wilhelm Strienz, 5.50, Programme in Dialect, 6.0, A Visit to Danzig—Programme for Young People, 6.20, Recital of Contemporary Music for Young People, 6.40, News, 6.50, Exchange; Sports Report, 7.0, Pearls in Wine—Sequence, 7.30, Love Songs on Records, 8.0, News, 8.10, Siegerland—Sequence with Records (Schreiber), 9.10, Three Scenes from Björnson's Olav Trygvason (Grieg), 10, News; Weekly Review, 10.40, Dance Music by the Casani Club Orchestra from London, 11.25, Concert of Cigany Music from Budapest, 12 Midnight, Close Down.

COPENHAGEN.—Relays Kalundborg, CORK.—Relays Athlone, DANZIG.—Relays Königsberg, DRESDEN.—Relays Leipzig.

FECAMP

1,456 kc/s, 206 metres; 10 kW.—11.0 to 11.30 a.m., Programme in English arranged by the International Broadcasting Company of London; Happy Half-Hour—Military Band Concert, 11.30, Programme in French, 4.30 to 6.0 p.m., Programme in English arranged by the I.B.C. (London), 4.30, Worthing, Littlehampton, Brighton and Hove Concert; Part I—This Heetic Life, 5.0, Part II—Dance Music, 5.30, Part III—Gramophone Records, 6.0, Programme in French, 11.0 till Close Down, Programme in English arranged by the I.B.C. (London), 11.0, Light Orchestral Concert, 11.30, Concert arranged by the I.B.C. (London), Ltd.: Tunes from the Talkies and Shows, 12 Midnight, Concert for Pencil Listeners; Dance Music, 12.30 a.m. (Friday), I.B.C. Time Signal, 12.31, Dance Music, 1.0, I.B.C. Good-night Melody and Close Down.

FLENSBURG.—Relays Hamburg, FLORINGEN.—Relays Milan.

FRANKFURT

1,195 kc/s, 251 metres; 17 kW.—5.45 a.m., Hymn; Time; Weather, 5.50, Gym, 6.40, Time; News, 6.50, Weather, 6.55, See Stuttgart, 8.10, Water Level; Weather, 8.15 to 8.35, Gym, 10.0, News, 10.45, Hints for the Housewife, 11.0, Announcements; Records, 11.30, Announcements; Economic Notes; Weather, 11.45, Social Notes, 12 Noon, Records of Light Music, 1.0 p.m., Time; News, 1.10, Local News, 1.20, Military Band Concert; Conductor, Hermann von der Dönnmühle; Overture, Nakiris Holzeitz (Lincke); Serenade (Métrica); Song from Nakiris Holzeitz (Lincke); Die türkische Scharwache (Michaelis); Selection from Der lustige Krieg (Joh. Strauss); Polka-Mazurka, Frauchenlerz (Jos. Strauss); Waltz, Ma bien aimé (Waldteufel). In the interval at 1.50, Time; News, 2.30, Economic Report, 2.45, Time; Economic Notes, 2.55, Weather, 3.10, The Soldier and the Dancer—Fairy Play for Children, 4.0, See Cologne, 5.30, Discussion: Art and Technique, 5.50, Topical Talk, 6.10, Talk; Cider, 6.25, Spanish Lesson, 6.45, Weather; Economic Notes; Programme Notes, 6.50, Request Records of Wedding Music, 7.30, Local News, 7.45, Topical News, 8.0, News; Art Notes, 8.15, Our Village—Munich, Hamburg, Königsberg, Frankfurt and Stuttgart Inter-Relay Programme. For details See Munich, 10.0, Time; News; Sports Notes, 10.15, Hermann Löns, Man and Poet—Literary and Musical Sequence (Eugen Weber), 11.0, See Hamburg, 12 Midnight, Vienna by Night—Records, 1.0 a.m. (Friday), Close Down.

FREDRIKSSTAD.—Relays Oslo, FREIBURG.—Relays Stuttgart, GENEVA.—Relays Sottens, GENOA.—Relays Milan, GLEIWITZ.—Relays Breslau, COTEBORG.—Relays Stockholm, GRAZ.—Relays Vienna, HAMAR.—Relays Oslo.

HAMBURG

904 kc/s, 331.9 metres; 100 kW. Relayed by Bremen, Flensburg, and Hanover, 1,330 kc/s, 225.6 metres.—5.45 a.m., Time; Announcements, 6.0, Gym, 6.15, Time; Weather, 6.20, See Berlin (Funkstunde). In the interval at 7.0, Time; News, 8.0, Weather; Talk; Convalescence, 8.10, Announcements; Records, 10.50, News, 11.0, Friedrich List—Biographical Play for Schools (Broekmeier), 11.45, Records, 12 Noon, Household Hints, 12.5 p.m., Time; Announcements, 12.15, Concert relayed from Königsberg, 1.0, Exchange; Weather, 1.20, Popular Music, 2.15, News, 2.30, Operetta Records, 3.0, Exchange, 3.40, Shipping; Aviation, 4.0, See Leipzig, 5.30, Talk; A University Student in the Labour

SEPT. 27th THURSDAY continued

Service. 5.45, Legal Talk. 6.0, Talks. 6.25, War Reminiscences. 6.45, Exchange; Weather. 7.0, Dance Music by the Station Band. Conductor: Bolt. 8.0, News. 8.15, Our Village—Munich, Stuttgart, Frankfurt, Hamburg, and Königsberg Inter-Relay Programme. (For Details see Munich.) 10.0, News. 10.20, Musical Programme. 11.0, Pianoforte Sonata in B flat (Mozart) by Edmund Schmid. 11.25, String Quartet in C minor, Op. 51 (Brahms) by the Schmalmaek Quartet. 12 Midnight, Dance Music by the Station Band and Soloists. Conductor: Gebhardt. 1.0 a.m. (Friday), Close Down.

HANOVER.—Relays Hamburg.

HILVERSUM

160 kc/s, 1,875 metres; 7 kW. (until 3.40 p.m.). Transmitted on Kootwijk, 50 kW., from 3.40 p.m. Programme of the General Broadcasting Society (A.V.R.O.).—7.40 a.m., Time; Records. 9.40, Time. 9.41, Service. 9.55, Records. 10.10, Recitations. 10.40, Recital by Boris Lensky (Violin) and Egbert Veen (Pianoforte): Sicilienne (Paradis-Beskin); Two Minnets (Schubert); Gavotte (Vieuxtemps); Largo (Dvorak); Slav Dances (Dvorak). 11.10, Records. 11.40, Time. 11.41, Light Music by John van Brück's Orchestra. In the interval, Records. 1.40 p.m., Chamber Music by The Hague Trio: Trio in C (Haydn); Trio in A minor, No. 2 (Chaminade). In the interval, Records. 2.40, Light Music by the Kovacs Lajos' Orchestra. 3.25, Interval. 3.40, Programme for Hospitals. 4.10, Records. 4.25, A Play for Children. 5.10, Light Music by Tuschinskii's Orchestra; Conductor, Max Tak. 6.10, Sports Talk. 6.40, Records. 7.10, Light Music by the Ramblers, relayed from The Hague; Conductor, Theo Masman. 7.40, Time; News. 7.45, Concert of Light Music by the A.V.R.O. Orchestra; Conductor, Nico Treep: Overture, Morning, Noon and Night (Suppé); Selection from White Horse Inn (Stolz-Benatzky-Krome); Abendlied (Schumann-Svendsen); Piece (Bull-Svendsen); The Cigarette Girl (Siede); Piece (Siede); Honeymoon March (Rosely). 8.30, Recitations. 8.50, L'Enfant prodigue—Cantata (Debussy) by the A.V.R.O. Choir and Orchestra; Hélène Cais (Soprano), Louis van Tulder (Tenor) and Willem Ravelli (Bari-tone); Conductor, Nico Treep. 9.40, Light Music by the Lajos Kiss Orchestra relayed from The Hague. 10.10, Records. 10.40, News. 10.50, Light Music. 11.40 (approx.), Close Down.

HORBY.—Relays Stockholm.

HUIZEN

995 kc/s, 301.5 metres; 7 kW (until 6.40 p.m.), 20 kW. from 6.40 p.m.—7.40 to 8.55 a.m., Programme of the Catholic Radio Society (K.R.O.). 7.40, Records. 9.40 to 10.40, Programme of the Christian Radio Society. 9.40, Records. 9.55, Religious Programme. 10.25, Records. 10.40 to 1.40 p.m., K.R.O. Programme. 10.40, Records. 11.10, Religious Address. 11.40, Police Notes. 11.55, Concert by the K.R.O. Orchestra; Conductor, van 't Woud: Los Banderilleros (Volpatti); Overture, Ramd um die Liebe (O. Straus); Hofballtänze (Lanner); Selection from A Life for the Zar (Glinka); The Singing Stream (Carr); Three Dances from Tom Jones (Gierman); Records; Overture, Raymond (Thomas); Herbststimmung (Rust); Insekten machen Musik (Zimmer); Mascarade (Lacôme); Lolita (Buzzi-Peccia); Grand Galop chromatique (Liszt). 1.40 till Close Down. N.C.R.V. Programme. 1.40, Handwork Lesson. 2.40, Recital by Karin Maria Kwant (Soprano) and Maur (Tenor). 3.25, Interval. 3.40, Bible Reading; Songs and Organ Music. 4.40, Handwork Programme for Young People. 5.10, Sacred Song Recital by de Haer. 6.10, Records. 6.40, Police Notes. 6.55, Records. 7.10, Press Review. 7.40, Records. 7.55, Recital by Mens (Organ), Mme. Sala (Soprano) and Isterdael (Cello), relayed from St. Peter's Church, Leyden; Organ: Sonata No. 1 (Mendelssohn); 'Cello: (a) Larghetto con poco moto (Léopold); (b) Cantabile (Nardini); Soprano: (a) Per la Gloria (Bubnoncini); (b) Care selve (Handel); (c) Allelujah (Mozart); Organ: Prelude, Fugue and Variations (Frank); 'Cello: Air (Jongen); Soprano: (a) Song (Meyer), (b) L'eglise paysanne (de Boeck); 'Cello: Adieu (Register); Song, Mein gläubiges Herz (Bach). 5.10, Talk for Parents. 9.40, News. 9.50, Dance Records. 11.25 (approx.), Close Down.

INNSBRUCK.—Relays Vienna.

KALUNDBORG

238 kc/s, 1,261 metres; 75 kW. Relayed by Copenhagen, 1,176 kc/s, 255.1 metres; and Skamlebaek, 49.5 metres—7.0 a.m., Gym. 8.30, Cathedral Service. 11.0, Weather. 11.10, Fish Prices. 11.15 to 11.45, French for Posh. 12 Noon, Time; Chimes. 12.5 p.m., Andersen's String Ensemble from the Bellevue Strand Hotel. 2.0, Interval. 2.40, Reading. 3.0, Concert by Teddy Petersen's Orchestra, from the Wivex. 4.45, A Microphone Visit. 5.30, Exchange. 5.42, A Poem. 5.45, Talk for Dairy Farmers. 6.15, English Lesson. 6.45, Weather. 6.54, Announcements. 7.0, News. 7.15, Time. 7.30,

Lecture-Recital: The Psalms. 8.10, Concert by the Radio Symphony Orchestra; Conductor, Nikolai Malko; Soloist, Conchita Supervia (Coloratura Soprano); Overture, The Italian Girl in Algiers (Rossini); Soprano Solos: Adagio from The Italian Girl in Algiers and Grand Rondo from La Cererentola (Rossini); I Pinindi Roma (Respighi); Ten Minutes Interval; Two Pieces (Albéniz-Arbos); Soprano Solos: (a) Tel majo diamanto (Granados), (b) Granada (Albéniz), (c) La Romeria de los Burlados (Pittaluga), (d) Polo (Nin); Spanish Caprice Op. 34 (Rimsky-Korsakov). 10.15, News. 10.30, Report: A Foreigner's Idea of Copenhagen. 11.10, Dance Music by the Jens Wagny Dance Band from the Nimb Restaurant. In the interval at 12 Midnight, Chimes. 12.30 a.m. (Friday), Close Down.

KIEL.—Relays Hamburg. **KLAGENFURT.**—Relays Vienna.

KONIGSBERG

1,031 kc/s, 291 metres; 60 kW. Relayed by Danzig, 1,303 kc/s, 230.2 metres—5.0 a.m., Records. 5.50 Weather. 6.0, Gym. 6.20, See Berlin (Funkstunde). In the interval at 7.0, News. 8.0, Prayers. 8.30 to 9.0, Gym. for Women. 9.5, Alfred Krupp—Play for Schools (Gert. R. Schmalnauer). 9.35, Talk for Housewives. 9.50, Gym. for Children. 10.40, News. 10.55, Weather. 11.30, Concert of New Light German Music, by the Small Station Orchestra, conducted by Eugen Wilchen. 1.0 p.m., Time; Weather. 1.5, Records of Classical and Romantic Music. In the intervals at 1.20 and 2.0, News. 2.30, Exchange. 3.0, Market Prices. 3.15, Book Review. 3.30, Eurythmics for Children. 4.0 (from Danzig), Concert by the Danzig State Theatre Orchestra; Conductor, Kallipke; Overture, Le domino noir (Anber); Selection from Der Wildschütz (Lortzing); Carnaval à Paris (Svendsen); Selection from The Gipsy Baron (Strauss); Polonaise No. 2 (Liszt); Waltz, España (Waldteufel); Slav Dances Nos. 5-8 (Dvorak); Pizzicato Polka (Joh. Strauss); Perpetuum mobile (Joh. Strauss); Intermezzo from Die Wallfahrt nach Mekka (Wetzel); Salut d'amour (Elgar); Overture, Don Giovanni (Mozart). 5.50 (from Danzig), Reading of short Stories (Hans Franck). 6.15, Market Prices. 6.25, Nature Study. 7.0, Violin Recital by Rolf Schroeder. 7.30, Folk Songs by a Boys' Choir; Conductor, Scholz. 8.0, News. 8.15, Our Village—Munich, Stuttgart, Frankfurt, Hamburg and Königsberg Inter-Relay Programme. (For Details see Munich.) 10.0, News. 10.30, Records. 10.40, Dance Music from London, followed by Cigány Music from Budapest. 12 Midnight, Close Down.

KOSICE.—Relays Prague. **LAUSANNE.**—Relays Sottens.

LEIPZIG

785 kc/s, 382.2 metres; 120 kW. Relayed by Dresden, 1,285 kc/s, 233.5 metres—5.50 a.m., Notes for Farmers. 6.0, Gym. 6.25, See Cologne. In the interval at 7.0, News. 8.0, Gym. 8.20 to 9.0, Records. 9.40, Exchange. 9.45, Programme Notes. 9.55, Weather; Water Level. 10.10 to 10.50, Through the Hartz Mountains—Sequence for Schools. 11.0, Announcements; Records. 11.30, News. 11.40, Weather. 11.45, Notes for Farmers. 12 Noon, Concert from Königsberg. 1.0 p.m., News. 1.10, Operetta Records. 2.0, News; Exchange; Weather. 2.15 to 2.45, Records of the Don Cossack Choir and Balalaika Orchestra. 3.40, Exchange. 4.0 (from Dresden), Concert by the Dresden Philharmonic Orchestra; Conductor, Schestak; Soloist, Hans Garvens (Violin); Overture, Così fan tutte (Mozart); Violin Concerto No. 8 (Sporb); Comely Suite (Wausel); Overture, Maritima (Wallace); Czardas, Zsambeki (Gungl); Suite champêtre (Chabrier); Ballet Music from Esmeralda (Drigo). 5.30, Talk: Caspar David Friedrich. 5.50, Exchange; Weather; Time. 6.0, War Reminiscences. 6.20, Concert of Folk Dances by the EmDe Orchestra and the German Folk Musicians' Society. 7.30, Talk: Acoustics. 7.50, News. 8.0, Promenade Concert relayed from London. 8.40, Twice Hanged Roskamm—Play (Wilk). 9.45, Dance Music from Stockholm. 10.20, News. 10.40, Dance Music from London. 11.20, Cigány Music from Budapest. 12 Midnight, Close Down.

LINZ.—Relays Vienna.

LUXEMBOURG

230 kc/s, 1,304 metres; 150 kW—7.45 a.m., Records. 8.0, News in French; Record; News in German; Record. 12 Noon, Concert by the Station Orchestra; Conductor, Pensis; Overture, Richard III (Gilson); Valse triste (Sibelius); Selection from Les Saltimbanques (Ganne); Contemplation, for Trio (Massellier); Air (Rimsky-Korsakov). 12.30 p.m., News in French and German. 12.40, Concert (cont'd.): Dance of the Merry Mascots (Kotelbey); Le Berger (Marsiek); Valse (Flévet); Four Pieces (Nerini). 1.0, Exchange. 1.5, Concert (cont'd.): Selection from The Dubarry (Millöcker-Mackeben);

Frühlingsanzug (Blon). 1.15, Records. 1.30, Exchange. 1.35, Records. 2.0, Exchange. 3.45, Exchange. 6.30, Concert of Light Music and Dance Music. 7.30, Recing Results. 7.35 till Close Down, German Evening. 7.35, Reading. 7.40, Song Recital by Papier (Bartone). 8.0, News in French and German. 8.20, Song Recital (cont'd.): Four Songs (Wolf): (a) In der Frühe, (b) Bitterolf, (c) Verborgtheit, (d) Der Musikant. 8.30, Exchange. 8.35, Concert by the Station Orchestra; Conductor, Pensis; Overture, Ondine (Lortzing); Réverie du Soir (Saint-Saëns); Liszt Potpourri (Urbach); Polichinelle (Rachmaninov); Valse célèbre (Mozzowsky); Suite, Nell Gwyn (German); Angelus (Micheli). 9.35, Concert of German Music by the Station Orchestra; Conductor, Pensis; Soloist, Ludwig Hoelscher (Cello); Concerto for 'Cello and Orchestra (Schumann); Divertimento, Op. 27 (Trapp). 10.25, Records.

MADRID

(EAJ7), 1,095 kc/s, 274 metres; 7 kW.—9.0 a.m., News. 10.0, Announcements; Exchange. 10.50, Interval. 2.0 p.m., Chimes; Time; Weather; Talk; Popular Music. 2.30, Sextet Concert. 3.0, Amusement Guide; Exchange; Popular Music. 3.30, Sextet Concert. 4.0, News; Popular Music. 4.30, Sextet Concert. 4.50, Announcements; Time; Interval. 5.0, Chimes; Light Music. 7.0, Announcements; Operatta Music. 7.30, Exchange; Flamenco Songs. 8.0, News; Organ Recital; Programme for Children. 9.40, Sports Notes. 10.0, Chimes; Time; Sextet Concert. 10.30, Concert from Paris (Ecole Supérieure). 11.30, News; Guitar Recital by Pepita Atalaya de Senor; Song (Chimes). 12.45 a.m., (Friday), News. 1.0, Chimes. 2.0 till Close Down. Programme in English arranged by the International Broadcasting Company of London; Dance Music. 3.0, I.B.C. Goodnight Melody; Close Down.

MADRID

EAQ, 10,000 kc/s, 30 metres; 20 kW.—11.15 p.m., News. 11.30, Spanish Music; News. 1.0 a.m. (Friday) to 1.30, Programme in English, arranged by the International Broadcasting Company of London; Orchestral Music. 1.30 a.m., I.B.C. Good-night Melody and Close Down.

MALMO.—Relays Stockholm.

MILAN

814 kc/s, 368.6 metres; 50 kW. Relayed by Turin, 1,140 kc/s, 263.2 metres; Genoa, 986 kc/s, 304.3 metres; and Florence, 610 kc/s, 491.8 metres—7.30 a.m., Gym. 7.45, Time; News. 8.0, Interval. 11.30, Popular Records. 12.45 p.m., News. 1.0, Time; Announcements. 1.5, Fashion Notes. 1.10, Concert by the Doreno Orchestra. In the interval at 1.30, Records; Exchange. 2.15 to 2.25, Exchange. 4.35, News. 4.45, Programme for Children. 5.10, Concert by the Ches-Zarandelli-Cassone Trio. 5.55, Weather. 6.0 to 6.10, Corn Prices. 7.0, Announcements. 7.15, News in Foreign Languages. 8.0, Time; News; Records. 8.30, Government Notes. 9.0, Symphonic Concert from Teatro Regio, Turin. 11.0, News.

MONTE CENERI

1,167 kc/s, 257.1 metres; 15 kW.—12 Noon, Announcements; News. 12.5 p.m. (approx.), Concert by the Station Orchestra. In the interval, at 12.29, Time; Weather. 12.55, News. 1.5, Sports Notes. 1.15, Records. 1.30, Interval. 3.59, Time. 4.0 to 6.0, See Sottens. 7.44, Announcements. 7.45, News. 8.0, Talk. 8.15, Records: Marches from Aida (Verdi); Carmen (Bizet); The Damnation of Faust (Berlioz); The Prophet (Meyerbeer); Faust (Gounod); The Force of Destiny (Verdi); and Tamhäuser (Wagner). 9.0, Sacred Songs by Anna Borellini; Prayer (Stradella); Crucifix (Fauré); Aria from Stabat Mater (Perzolesi). 9.15, Records; Mandoline Music. 10.0, Close Down.

MORAVSKA-OSTRAVA

1,158 kc/s, 259.1 metres; 11.2 kW.—6.0 to 7.15 a.m., See Prague. 9.50, See Prague. 10.30, See Brno 11.0, See Prague. 12.30 p.m., See Bratislava. 1.30, See Prague. 2.0 to 2.10, See Brno. 3.15 to 4.20, See Prague. 4.40, See Prague. 5.40, Talk. 5.50, Tourist Report. 6.0, News. 6.5, Book Review. 6.15, Record. 6.20, German Transmission; Song Recital by Mme. Funk; Records. 6.55, See Prague. 7.35, Reading. 7.50, Record. 7.55, See Prague. 11.0 (approx.), Close Down.

MOSCOW (No. 1)

174 kc/s, 1,724 metres; 500 kW.—5.0 a.m., News. 5.15, Fanfare. 5.45, Gym. 6.15, Musical Programme. 8.15, Programme for Children. 9.0, Musical Programme. 9.58, Time. 10.0, News. 10.15, Concert for Collectivist Farmers. 3.0 p.m., Programme Announcements. 3.15, Programme for Children. 3.58, Time. 4.0, News. 4.30, Communist Party Programme. 5.30, Red Army Programme. 6.30, Talk for Collectivist Farmers. 8.0, Concert. 9.0, Press Review

in German. 9.55, Chimes. 10.5, Talk in French: The Harvest. 11.5, Talk in Spanish: The Harvest.

MOTALA.—Relays Stockholm. **MUHLACKER.**—See Stuttgart.

MUNICH

740 kc/s, 405.4 metres; 100 kW. Relayed by Augsburg and Nürnberg, 1,267 kc/s, 236.8 metres—6.30 a.m., Gym. 6.45, Motto; Records. 7.15, Time; News. 7.25, See Stuttgart. 9.50, Talk for Housewives. 10.0, Our Daily Bread—Harvest Home Sequence (Bedall). 10.40, Notes for Farmers. 10.50, Market Prices. 11.0, Programme for Farmers. 11.20, Time; News. 11.30, Post Office Programme; Records. 12 Noon, Records. 1.15, Time; News. 1.25, Lincke Concert by the Small Station Orchestra; Conductor, Kloss: Ballet Overture; Herbststimmung; Indra-Polka; Intermezzo, Sylphide; Aminta; Overture to an Operetta. 2.0, News. 2.20, Recital by Nini Diehl (Soprano), Gernot Burrow (Bass) and Erika Lyncker (Pianoforte): Soprano Songs (Richard Strauss): (a) Du meines Herzens Kronelein, (b) Die Nacht, (c) Hoffen und Meiden; Ballad in G minor (Grieg); Baritone Songs (Ertel): (a) In einer Sturmzeit, (b) Jane Grey, (c) Trinklied der Landsknechte. 3.0, Reading (Auzinger). 3.30, Programme for Women. 3.50, Weather; Programme for Farmers. 4.0, Concert by the Small Station Orchestra; Conductor, Kloss: Overture, Masaniello (Auber); Aria from the Suite in D (Bach); Gavotte from the Violin Sonata (Bach); Scenes from Der Freischütz (Weber); Waltz, Klänge aus Wien (Döring); Cradle Song (Dowell); Fairy Tale (Poldini); Kéler-Béla Potpourri (Rhode); Es leuchtet der Mond (Leopold); Suite (Micheli). 5.30, Talk: Trading in Works of Art. 5.50, Grün ist die Heide—Hermann Löns Sequence (Weinberger); by Helma Panka (Soprano) and Besenfelder (Songs to the Lute). 6.30, Talk: Superstitious. 6.50, Time; Weather; Programme for Farmers. 7.0, Loewe Recital by the Kraft Quartet, Luise Pfleger (Soprano), Georg Hann (Baritone), and Otto Pfanzelt (Clarinet); Extracts from the Pianoforte Trio in G minor, Op. 12; Songs for Soprano: (a) Das vergessene Lied, (b) Die Mutter an der Wiege; Songs for Baritone: (a) Odins Meeresritt, (b) Der Mönch zu Pisa; Pieces from Scottish Pictures, Op. 112; Songs for Soprano: (a) Süßes Begräbnis, (b) Schwalbenmärchen, (c) Niemand hat's gesehen; Songs for Baritone: (a) Meeresleuchten, (b) Prinz Eugen; Extracts from the String Quartet in F, Op. 24, No. 2. 8.0, News. 8.15, Our Village—Munich, Hamburg, Königsberg, Frankfurt and Stuttgart Inter-Relay Programme: Munich, Bavarian Harvest Home; Hamburg, Fishing Village; Königsberg, Frontier Village; Frankfurt, Wine District Village; Stuttgart, Harvest Moon in the Swabian Alps. 10.0, News; Sports Notes. 10.20, Programme to be announced. 10.40, Dance Music from London. 11.25, Cigány Music from Budapest.

NAPLES.—Relays Rome. **NOTODDEN.**—Relays Oslo.

OSLO

254 kc/s, 1,154 metres; 60 kW. Relayed by Hamar, 519 kc/s, 578 metres; and Jeløy, 6,990 kc/s, 42.92 metres—10.0 a.m., Egg Prices. 11.15, Service. 11.35, Records. 11.50, Nauen Time Signal. 1.0 to 2.0 p.m., Records. In the intervals at 1.15, Weather; Talk for Farmers, and at 1.45, Exchange. 5.0, The Seventh Scandinavian Music Festival—Finnish and Danish Chamber Music; Soloists, Byrthing and Ester Ingman (Songs); Quintet for Pianoforte, Two Violins, Viola and 'Cello (Raito); Songs by M. Byrthing; Trio for Flute, Clarinet, and Bassoon (Melartim); Kilpinen Songs by Ester Ingman; Sonata for 'Cello and Pianoforte, Op. 14 (Gram). 6.30, Service. 7.0, Announcements. 7.15, Weather; News. 7.30, Time. 7.31, Bellman Song Recital. 8.0, Programme for Farmers. 8.30, Concert of Light Music. 9.10, Medical Talk. 9.40, Weather. 9.45, News. 10.0, Topical Talk. 10.15, Violin Recital of Old Dances by Bolstad. 10.45, Close Down.

OSTERSUND.—Relays Stockholm.

PARIS

ECOLE SUPERIEURE, 695 kc/s, 431.7 metres; 7 kW.—12 Noon, Tourist Report. 12.15 p.m., Popular Records. 1.0, News. 1.15, Concert relayed from Lille, 1,213 kc/s, 247.3 metres. 2.0, Operetta and Dance Records. 4.0, Records. 5.30, Esperanto Lesson. 6.0, Art Review. 6.30, News. 7.45, Talk: Hygiene. 7.53, Talk. 8.0, Dalcroze Records. 8.30, Concert of Chamber Music: Trio for Flute, Clarinet and Pianoforte (Weber); Songs (Schubert); (a) Die Krähe, (b) Die Stadt, (c) Heideröslein; Piece for Flute and Pianoforte (Blavot); Interlude: Recitations: Pianoforte (a) Etude in A flat (Chopin), (b) Jardins sous la pluie (Debussy); Songs: (a) Norwegian Songs (Gorge), (b) Fedia (Erlanger), (c) Cingarella (Tomasi); Violin and Pianoforte Sonata (Franck). 10.25 (approx.), News. 10.30, European Concert by the National Orchestra; Conductor, Inghibredt; Soloists, Bassant (Pianoforte), and Elsa Ruhlmann (Songs); Overture, Carnaval roman (Berlioz); Ballad for Pianoforte and Orchestra (Fauré); Prélude à l'après-midi

d'un faune (Debussy); Song; Schéhérazade (Ravel); Nappes from Impressions d'Italie (Charpentier).

PARIS

POSTE PARISIEN, 959 kc/s, 312.8 metres; 100 kW.—7.10 a.m., Records. In the intervals, Press Review; Cookery Hints. 12 Noon, Exchange. 12.5 p.m., Records of Military Music. 12.15, Programme by Kito, the Clown. 12.25, News. 12.35, Concert. 1.5, Exchange. 1.15, Records for Children. 1.35, New Records. 2.0, Exchange. 3.15, Exchange. 3.45, Exchange. 6.45, Exchange. 6.49, Extracts from Lakmé (Delibes) on Records. 7.10, News. 7.30, Programme for Children. 8.0, Talk. 8.10, Weekly Review by Max Régner. 8.15, Concert. 8.45, Exchange. 8.55, Cigány Music from the Café Martin. 9.30, Interval. 9.40, Concert. 10.20, News; Exchange. 10.30 till Close Down, Programme in English arranged by the International Broadcasting Company of London. 10.30, Tunes from the Talkies and Shows. 10.45, Concert, Dancing Memories. 11.0, I.B.C. Good-night Melody; Close Down.

PARIS

RADIO-PARIS, 182 kc/s, 1,648 metres; 75 kW.—6.45 a.m., Gym. 7.0; Records. 7.15, News. 7.45, Gym. 8.0, Records. 12 Noon, Protestant Address. 12.30 p.m., Concert by the Victor Pascal Orchestra: Serenade Berceuse (Lucciani); Romanian Song (Liamine); March (Stolz); Song (Denza); Pianoforte Solo; Waltz (Fryberg); Tarantella (Volpatti); Serenade (de Micheli); Ronde; Violin Solo; March (de Micheli); Spanish Dance (Granados); Romance (Schmalstieg); Selection from White Horse Inn (Benatzky); 'Cello Solo; Flamenca (Santis); Se tu vorreste (Tosti); Synopation (Kreisler); Hungarian Czardas (Leoni); Song, Santa Lucia (Mario); Overture, La finta giardiniera (Mozart); Song, Sorrentina (Volpatti); Suite of Waltzes from Eva (Lehár). In the interval at 1.20, Exchange. 3.45, Exchange. 6.20, Announcements; Talk; Exchange; Racing Results. 6.45, Talk. 7.0, Reading. 7.30, Topical Talk. 8.0, Vocal Concert. In the intervals at 8.30, News, and at 9.15, News; Review by Paul Reboux. 10.30, See 'Paris (Ecole Supérieure).

PITTSBURGH

KDKA, 980 kc/s, 306 metres; 50 kW. Relayed by WXK on 48.86 metres, and 25.27 metres.—3.0 p.m., Edward MacHugh. 3.15, Castles of Romance. 3.30, To-day's Children. 3.45, News; Cookery Hints. 4.0, Hazel Arth (Contralto). 4.15, Tony Wons. 4.30, Frances Ingram. 4.45, United States Navy Band. 5.0, Fields and Hall. 5.15, Merry Maes. 5.30, Vic and Sade. 5.45, Hotel William Penn Orchestra. 6.0, Exchange. 6.15, Honourable Archie and Frank. 6.30, Farm and Home Hour. 7.30, KDKA Home Forum. 8.0, Tommy Tucker's Orchestra. 8.30, Music Magic. 8.45, State Federation Pa. Women. 9.0, Betty and Bob. 9.15, Dorothy Page. 9.30, Exchange. 9.45, (Chicago Symphony Orchestra. 10.15, KDKA Kiddies' Klub. 10.30, The Singing Lady. 10.45, Orphan Annie. 11.0, Dan and Sylvia. 11.14, Baseball Résumé. 11.30, Kings and Queens of Sport. 11.45, Lowell Thomas. 12 Midnight, Amos 'n' Andy. 12.15 a.m. (Friday), Lois Miller and Reed Kennedy. 12.45, Music; News. 1.0 to 6.0 a.m., Popular Programme.

PORSGRUND.—Relays Oslo.

PONTOISE

RADIO-COLONIAL, 15,244 kc/s, 19.68 metres; 15 kW. (1.30 to 5.0 p.m.); 11,905 kc/s, 25.20 metres (5.15 to 12 Midnight), and 11,705 kc/s, 25.63 metres (12.15 a.m. Monday to 6.0).—4.0 to 5.0 p.m., Octet Concert: Selection from Il Seraglio (Mozart); Gavotte (Martini); Jeux d'enfants (Bizet); Selection from Romeo and Juliet (Gounod); Serenade (Mesquita); Selection from The Arabian Nights (Joh. Strauss); Selection from Show Boat (Kern). 6.30 to 7.30, Quintet Concert: Selection from Les Noces de Jeannette (Massé); Chaconne and Rigaudon (Monsigny); Russian Suite (Doyen); Selection from Werther (Massenet); Arioso (Bach); Bouffées printanières (Waldteufel); Selection from Les Cloches de Corneville (Planchette). 8.30, Programme to be announced. 1.0 a.m. (Friday), Recital of Old and New Songs by Suzy Vinker.

PRAGUE

638 kc/s, 470.2 metres; 120 kW.—6.0 a.m., Time; Gym; Music; News. 7.15, Interval. 9.50, News. 10.5, News in German. 10.10, Records. 10.30, See Brno. 11.0, Record. 11.5, Broadcast for Schools. 11.55, Notes for Farmers. 12 Noon, Time; Records. 12.20 p.m., News. 12.30, See Bratislava. 1.30, Talk; Economics. 1.40, Records. 1.50, Exchange. 1.55, Exchange and Weather in German. 2.0, Interval. 3.15, Concert by the Station Orchestra; Conductor, Parik; Overture, Patrie (Bizet); At Twilight (Fibich); Slovak Melodies (Konrad); Scherzo in D (Sequens); Waltz, Roses from the South (Joh. Strauss). 4.15 to 4.20, News. 4.40, Dance Music by the Symphony Jazz Band. 5.40, Announcement. 5.45, Talk for Farmers. 5.55, Record. 6.0, Talk for Workers. 6.10, German Transmission; Book Review; Talk for Farmers. 6.55, News. 7.0, Time; News.

SEPT. 27th THURSDAY continued

7.10, Children's Songs by the Prague Chamber Orchestra and Soloists; Conductor, Herti. 7.35, The Stoker and Mechanic of an International Express at the Microphone. 7.55, Introductory Talk to the following Relay. 8.0, Concert of Dvorák's Slav Dances by the Czech Philharmonic Orchestra, relayed from the Smetana Concert Hall; Conductor, Jerenias. 10.0, Time; News. 10.15, Dance Music by the Czech Jazz Band. 11.0 (approx.), Close Down.

RIGA

583 kc/s, 514.6 metres; 15 kW.—6.0 a.m., Choral. 6.5, Gym. 6.40 to 7.10, Concert. 11.0, Exchange. 11.5, Records. 11.30, Weather. 11.35, News. 12 Noon, Gardening Talk. 3.50 p.m., Records. 4.20, Talk: The Theatre. 4.50, Accordion Recital of Latvian Songs and Dances. 5.20, Talk. 5.50, Latvian Song Recital by Olga Vitolins. 6.10, Variety Programme. 6.40, English Lesson. 7.10, Weather. 7.15, Symphony Concert by the Station Orchestra; Conductor: Medius; Soloist: Pauls Suberts (Pianoforte); Symphonic Suite, Scheherazade (Rimsky-Korsakov); Pianoforte Concerto in A Minor (Grieg); Overture, Sakuntala (Goldmark); Dances from Prince Igor (Borodin). In the Interval at 8.0, News, and at 9.0, Weather; News. 9.30, Concert of Light Music. 10.0, Concert of Fall Operetta Music.

RJUKAN.—Relays Oslo.

ROME

Call 1R0, 713 kc/s, 420.8 metres; 50 kW. Relayed by Naples, 1,104 kc/s, 271.7 metres; Milan No. 2, 1,348 kc/s, 222.6 metres; Turin No. 2, 1,357 kc/s, 221.1 metres; and 2R0, 11,810 kc/s, 25.4 metres.—7.30 a.m., Gym. 7.45, Time; News. 8.0, Interval. 12.30 p.m., Records. 1.5, Popular Concert. In the interval at 1.30, Time; News; Exchange. 2.15, Interval. 4.30, Programme for Children. 4.50, News; Exchange. 5.0, Recital by Tina Bari (Violin), Agnese Dubbini (Soprano), and Maria Pisani and Edvige Risca (Songs); Violin: Movements from the Sonata in G Minor (Locatelli); Soprano Solos: (a) Madrigal, (Sonnetti), (b) La castellana (Pennacchio), (c) Ave Maria from I Lombardi (Verdi); Violin Solos (Kreisler): (a) Liebesleid, (b) Liebesfreud; Duets from: (a) Titus (Mozart), (b) Le roi de Lahore (Massenet), (c) La regata veneziana (Rossini). 5.55, Weather. 6.0 to 6.10, Corn Prices. 7.0, Announcements. 7.15, News in Foreign Languages. 8.0, Time; News. 8.10, Records. 8.30, Government Notes. 8.45, Concert. In the intervals, Theatre Talk and Review. After the concert, News.

RUYSSELEDE

10,330 kc/s, 29.04 metres; 8 kW.—7.45 p.m., News in French. 8.0, See Brussels (No. 1). 9.0, News in Flemish. 9.15, Close Down.

SALZBURG.—Relays Vienna.

SCHENECTADY

WGY, 790 kc/s, 379.5 metres; 50 kW. Relayed at intervals by W2XAF on 31.48 metres and by W2XAD on 19.56 metres.—7.0 p.m., Dreams Come True; Barry McKinley (Songs). 7.15, Musical Programme. 7.30, Woman's Radio Review; Talks; Orchestra. 11.25, Exchange. 12 Midnight, Fleischmann Hour with Rudy Vallee's Orchestra. 1.0 to 3.0 a.m. (Friday), Popular Programme.

SOTTENS

677 kc/s, 443.1 metres; 25 kW.; and Geneva, 401 kc/s, 748 metres.—7.0 to 7.15 a.m., Gym. 12.29 p.m., Time. 12.30, News. 12.40 (from Geneva), Records. In the interval at 1.0, Exchange. 2.0, Interval. 3.59, Time. 4.0 (from Geneva), Concert by the Station Orchestra; Conductor, Echenard; Three Pieces (Debussy): (a) Marche écossaise, (b) Dance, (c) La boîte à bijoux; Extract from Pelléas et Mélisande (Fauré); Mother Goose (Ravel). 4.45, To be announced. 5.10, Concert (contd.): Extract from Orpheus in the Underworld (Offenbach); Ballet du printemps (Thomas); Mélodrame de Piccolino (Guiraud); Minuet for Flute (Glück); Bacchanale from Samson and Delilah (Saint-Saëns). 6.0 (from Geneva), Reading for Children. 6.20 (from Geneva), Talk for Children. 6.30 (from Geneva), Bridge Lesson. 6.45 (from Geneva), Talk for Mountaineers. 7.0 (from Geneva), Suite Ancienne for Violin and Pianoforte (Rhené-Baton). 7.15 (from Geneva), Talk: The International Music Festival in Venice. 7.40 (from Geneva), News. 7.59, Weather. 8.0 (from Geneva), Quartet No. 3 (Glière), by the Klein Quartet. 8.30 (from Geneva), Talk: Sinal. 8.45, Concert by the Station Orchestra; Conductor, Echenard; Concerto in G (Bach); Violin Concerto in A minor (Bach); Octet (Schubert). In the interval at 9.15, News. 10.0 (from Geneva), Talk: The Work of the League of Nations. 10.20 (from Geneva), Popular Songs. 10.50 (approx.), Close Down.

STOCKHOLM

704 kc/s, 426.1 metres; 55 kW. Relayed by Boden and Östersund, 413.5 kc/s, 726 metres; Göteborg, 941 kc/s, 318.8 metres; Hörby, 1,131 kc/s, 265.3 metres; Motala, 216 kc/s, 1,389 metres; and Sundsvall, 601 kc/s, 499.2 metres.—7.20 a.m., Gym. 7.45, Prayer. 8.0, Weather. 12.30 p.m., Weather. 12.45, Exchange. 12.55, Time. 1.0, Extract from Master Olof—Play (Strindberg). 1.45 (from Göteborg), Light Music. 2.45, Talk. 3.0, Interval. 5.0, Weather. 5.5 (from Östersund), Service. 5.30, Concert from Oslo. 6.15, Records. 6.45, English Lesson. 7.15, Weather; News. 7.30, Records of Viennese Music. 7.50, Talk from Malmö, 1,312 kc/s, 228.7 metres. 8.20, Coloratura Soprano and Baritone Recital by Eugénie Triguez and Donald Campbell; Coloratura Soprano Solos: Lo, hear the gentle Lark (Bishop); Little Boats (Hughes); Girometta (Sibella); Lullaby (Sadero); Una voce poco fa (Rossini); Scottish Folk Songs for Baritone: The Scots wha hae, The Rowan Tree, The wee wee German Lairdie, Ae fond Kiss; Nancy's Hair; Duets (Parcell): (a) Let us wander. (b) My dearest, my fairest, (c) Shepherd, Shepherd, leave decoying; Duet from Don Giovanni (Mozart). 9.0, Dance Music from Warsaw; Cigány Music from Budapest. 10.0, Dance Music. 10.40, Dance Music from London. 11.25, Close Down.

STRASBOURG

859 kc/s, 349.2 metres; 15 kW.—11.0 a.m., Concert relayed from Bordeaux-Lafayette, 1,077 kc/s, 278.6 metres. 12 Noon, Records of Light Music. 12.45 p.m., News. 1.0, Time; Exchange. 1.5, Records. 1.15, Orchestral Concert relayed from Lille, 1,213 kc/s, 247.3 metres. 2.0, Programme for Children. 3.0, Interval. 4.0, See Paris (Radio Colonial). 5.0, Orchestral Concert relayed from Marseille, 749 kc/s, 400.5 metres. 6.0, Talk in German: America. 6.15, History Talk: Lucile Desmoulins. 6.30, Orchestral Concert; Conductor, de Villers; Overture, Romeo and Juliet (Tchaikovsky); Selection from Lohengrin (Wagner); Symphonic Poem, Helvetia (Scassola); Algerian Suite (Saint-Saëns). 7.30, Time; News. 7.45, Local News. 8.0, Press Review in German; Lottery Results; Announcements. 8.30, Dramatic Programme: (a) Silhouette—Sketch (Fay), (b) Une visite de nocces—One-Act Play (Dumas fils), (c) C'était hier—Dialogue (Hervier), (d) A la porte—One-Act Play (Verconsin). In the interval at 9.30, News. 10.30, See Paris (Ecole Supérieure). 1.30 (approx.), Close Down.

STUTTART

MUHLACKER, 574 kc/s, 522.6 metres; 100 kW.—5.35 a.m., Programme for Farmers. 5.45, Hymn; Time; Weather. 5.50, Gym. 6.15, Military Band Concert. 6.40, Time; News. 6.55, Military Band Concert (contd.). 8.10, Weather. 8.15, Gym. 8.35, Water Level. 8.40, Interval. 9.0, Gym. for Women. 9.15, Interval. 10.0, News. 10.10, A Visit to a Library of World-War Books (on Records). 10.40, Two Pieces, Op. 36 (Max von Schillings): (a) Helledunkel, (b) Invokation, by Gerhard Eucken (Pianoforte). 11.0, Recital of Music in Waltz Time by Fritz Ries, from the Ufa-Palast. 11.25, Records; Announcements. 11.40, Technical Talk for Farmers. 11.55, Weather. 12 Noon, See Frankfurt. 1.0 p.m., Announcements. 1.20, See Frankfurt. 1.50, News. 2.0, See Frankfurt. 2.30, Interval. 3.15, Programme of Music and Fairy Tales for Children. 4.0, See Cologne. 5.30, Discussion: Memorials. 5.45, Fairy Tales and Legends in Song—Recital by Gertrud Probst (Soprano): Es war ein alter König (Wolf); Die Fischerkinder (Pfitzer); Maria und der Schiffer (Knab); Mir träumte von einem Königskind (Trunk); Song (Gounod); Die schwarze Laute (Graener). 6.15, Astronomy Talk. 6.25, Spanish Lesson. 6.45, Recital on Eight Pianofortes by Music School Students: Overture, Semiramis (Rossini). 7.0, Roses White and Red—Sequence of Folk Music (Ganss), by the Station Choir and Orchestra, a Zither Trio and Soloists; Conductor, Ganss. 7.30, Local Review. 7.40, Time; Weather; Talk for Farmers. 8.0, News. 8.15, Our Village—Munich, Hamburg, Königsberg, Frankfurt and Stuttgart Inter-Relay Programme. (For Details see Munich.) 10.0, Concert by the Otto Schulrabe Balaika Orchestra: Russian March; Russian Waltz (Küss); Russian Folk Song Potpourri (Schulrabe). 10.20, Time; News; Sports Report. 10.40, Dance Music by the Casani Club Orchestra, from London. 11.25, Concert of Cigány Music from Budapest. 12 Midnight, See Frankfurt. 1.0 a.m., Close Down.

SUNDSVALL.—Relays Stockholm.

TOULOUSE

913 kc/s, 328.6 metres; 10 kW.—8.0 a.m., Dance Refrains. 8.30, News. 8.35, Orchestral and Sound Film Music. 12 Noon, Viennese Orchestra. 12.15 p.m., Light Music. 12.30, News. 12.45, Request Music. 1.0, Harvest Songs. 1.15, Paysanneries—Radio Fantasy. 1.30, Symphony Orchestra. 1.45, Oper-

etta Music. 2.0, News. 6.0, News. 6.15, Military Music. 6.30, Opera Arias. 6.45, Orchestral Music. 7.0, Sound Film Music. 7.15, Operetta Music: Song from Countess Maritza (Kálmán); Selection from (a) The Land of Smiles (Lehár), (b) The Chocolate Soldier (O. Straus), (c) Ciboulette (Hahn). 7.30, News; Exchange. 7.45, Russian Songs. 8.0, Concert of Harvest Songs. 8.30, Talk: South-Western Corn Markets. 9.0, A Visit to a Granary. 9.30, Folk Songs. 10.0, An Anecdote. 10.10, A Fable (La Fontaine), with Music. 10.15, News. 10.30, Harvest Festival Concert: Overture, Poet and Peasant (Suppé); Invocation à la nature (Massenet); Eglogue, Poème Virgilien (Rabaud); Heureux petit berger (Gounod); Selection from Messidor (Bruneau); Légende de la sauge (Massenet); To Spring (Grieg). 11.15, A Village Festival—Sequence. 12 Midnight, News. 12.5 a.m. (Friday), Au moulin de la chanson—Radio Fantasy. 12.15, Viennese Orchestra. 12.30 (approx.), Close Down.

TRONDHEIM.—Relays Oslo. TURIN.—Relays Milan.

VATICAN CITY

15,120 kc/s, 19.84 metres; 10 kW. (Morning); 5,970 kc/s, 50.26 metres (Evening).—11.0 to 11.15 a.m., Religious Information in French. 8.0 to 8.15 p.m., Religious Information in Italian.

VIENNA

592 kc/s, 506.8 metres; 120 kW. Relayed by Graz, 886 kc/s, 338.6 metres; Innsbruck, 519 kc/s, 578 metres; Klagenfurt, Linz, and Salzburg, 1,294 kc/s, 231.8 metres.—9.0 a.m., News. 9.20, Market Prices. 9.30, Weather. 10.50, Water Level. 11.30, Talk: Austria. 11.55, Weather. 12 Noon, Concert by the Vienna Symphony Orchestra; Conductor, Holzer; Soloist, Rosner (Violin): Overture, Der Bettelstudent (Müllöcker); Tales of the Danube (Morena); Harlequinade for Violin (Rosner); Andante with Variations (Seidler); Waltz, Liebe im Mai (Strauss); Selection from Eva (Lehár); March (Silving); Dance Suite (Stilp); Serenata (Toselli); Waltz (Zeilner); Potpourri (Hrubý). In the interval at 1.9 p.m., News. 2.0, Announcements. 2.10, Records of Famous Singers. 3.30, News. 3.50, Programme for Unemployed Youth. 4.10, News. 4.15, Tales for Children. 4.55, Opera Records. 5.10, Violin Recital by Adler: La Folia (Corelli-Leonard); Humoresque (Kaiser); Der Zephir (Hubay); Abendlied (Glück); Perpetuum mobile (Novacek). 5.45, Talk: Heating Problems. 6.0, Talk: Thought. 6.25, Talk: Television. 6.50, Theatre Notes. 7.0, News. 7.20, Talk: Radio Marvels. 7.50, Strauss Concert by the Vienna Symphony Orchestra; Conductor, Holzer; Soloist, Maria Gerhart (Soprano); Johann Strauss Senr.: Radetzky March; Waltz, Loreley-Rheinklänge; Annenpolka; Johann Strauss, Jmnr.: Waltz, Frühlingsstimmen; Overture, Die Fledermaus; Waltz, The Blue Danube; March from Simplicius; Waltz, Wo die Zitronen buh'n; Polka and Czardas from Ritter Pasmán; Intermezzo from The Arabian Nights; Bacchanale from Indigo; Overture, Prince Methusalem; Josef Strauss: Waltz, Mein Lebenslauf ist Lieb und Lust; Polka; Frauenherz; Dorfschwalben aus Oesterreich; Overture, Frühlingsluft; Eduard Strauss: Doktrinen-Walzer; Johann Strauss (Grandson): Gallop, Frisch durch's Leben. 9.50, Topical Talk. 10.10, News. 10.30, Orchestral Concert from Paris. 11.30, Dance Music by the David Mathé Band from the Café Palmhof; Soloist, Viktor Sternau (Songs). 1.0 a.m. (Friday), Close Down.

WARSAW

223 kc/s, 1,345 metres; 120 kW.—6.45 a.m., Hymn. 6.48, Records. 6.58, Gym. 7.8, Records. 7.15, News. 7.25, Records. 7.35, Hints for Housewives. 7.40, Programme Announcements. 7.50, Announcements; Light Music. 8.0, Interval. 11.57, Time. 12 Noon, Fanfare from St. Mary's Church, Cracow. 12.3 p.m., Weather. 12.5, Press Review. 12.10, Programme for Children. 12.30, Records. 1.0, News. 1.5, Labour Exchange. 1.10, Records. 1.45, Interval. 3.30, Announcements. 3.35, Exchange. 3.45, Concert of Light Music by the Górzynski Jazz Band; Soloist, Górska (Songs). 4.45, French Lesson. 5.0, Hamlet—Tragedy (Shakespeare). 6.15, Letterbox. 6.25, Talk for Farmers. 6.40, Violin Recital by Stella Dorthelmer, relayed from Cracow, 986 kc/s, 304.3 metres. 7.0, Talk on Books. 7.15, Song Recital by Dygas. 7.35, Topical Talk. 7.45, Programme Announcements. 7.50, Sports Notes. 8.0, Jazz Music by Altenberg and Rybczynski (Pianofortes) and Olga Lada (Songs). 8.30, Concert of Popular Polish Music: Soloist, Bogucki (Songs); Potpourri of Polish Melodies (Suchocki); Mazurka (Osmański); Cotuavianne; Polka (Dzierzanowski); Oberek (Suchocki); Mazurka (Wronski); Mountain Songs (Dzierzanowski); Mazurka (Namysłowski); Krakowiacki (Dzierzanowski); Oberek (Suchocki). 9.15, News. 9.25, Talk. 9.30, Records. 9.45, Talk. 10.0, Announcements; Light Music. 10.15, Three Eternal Songs, Op. 10 (Karłowicz) by the Station Symphony Orchestra; Conductor, Stranszynski. 10.45, Talk in English: Sport in Poland. 11.0, Weather. 11.5, Dance Music from the Paradis.

ZURICH.—Relays Bernünster.

ATHLONE

565 kc/s, 531 metres; 60 kW. Relayed by **Dublin**, 1,348 kc/s, 222.6 metres; and **Cork**, 1,240 kc/s, 241.9 metres.—1.50 to 2.30 p.m., Time; Exchange; Weather; Records. 4.0, Concert from Robert's Café; Soloist, John Lysney. 6.0, Programme for Children. 6.45, News. 7.0, Gardening Talk. 7.15, Literary and Dramatic Talk. 7.30, Time. 7.31, Concert by the Station Orchestra. 7.50, Song Recital by E. Kirk (Contralto). 8.0, Pianoforte Recital by Joan Trimble. 8.10, Contralto Song Recital (contd.). 8.20, Vocal Duets by Mollie Phillips and Robert Irwin, with Orchestra. 8.45, Val Vouden (Entertainer). 9.0, Concert by the Station String Orchestra. 9.15, Song Recital by T. Walshe (Tenor). 9.30, Concert by the Siansa Gaedhead Band. 10.0, Variety Programme. 10.30, Time; News; Weather. 10.40, Variety Programme by the Nono Brothers. 11.0, Close Down.

BARCELONA

795 kc/s, 377.4 metres; 5 kW.—8.15 a.m., News; Records. 9.0, Chimes; Gym; Records. 9.20, News; Records. 10.0, Obituary. 12 Noon, Chimes; Weather. 1.0 p.m., Programme for Women. 1.45, Records. 2.0, Records. 2.30, Theatre Notes; Amusement Guide; Records. 3.0, sextet Concert; Tourist Talk in the interval. 3.45, Exchange. 4.0, Programme for Hospitals. 5.0, News. 7.0, Trio Concert. In the interval at 7.30, News. 8.0, Request Records. 8.30, Exchange; Request Records. 9.0, Wireless Notes. 9.10, Records. 9.30, Educational Programme for Children. 9.40, Records. 9.45, Press Review. 10.0, Chimes; Weather; Announcements, Programme for Seamen; Exchange. 10.10, Concert by the Station Orchestra: España cañi (Rabaud); Selection from Marouf (Mabrouk); Waltz (Krone); Piece (Gog); Gavotte (Wollstedt); Indian Wedding (Percy); Dance (Corbellini). 11.15, Choral Concert. 12 Midnight, Dance Music by the Melody Boys' Orchestra from the Shang-hai Bar. 1.0 a.m. (Saturday), News and Close Down.

BASLE.—Relays **Beromünster**.

BELGRADE

685 kc/s, 437.3 metres; 2.5 kW.—10.45, a.m., Programme Announcements. 10.50, Water Level. 11.0, Concert by the Station Orchestra. 11.59, Chimes. 12.5 p.m., Records. 12.15, Recital of Opera Arias by Mme. Nikovic-Grosano; Arias from Mignon (Thomas), La Bohème (Puccini), La Traviata (Verdi). 12.45, Exchange; Announcements. 1.10, Records. 1.30, News; Time. 4.0, Gym. for Children. 4.30, Concert by the Station Orchestra: Overture, The Daughter of the Regiment (Donizetti); Lyric Suite (Lindner); Piece (Mokraujatz); Dance of the Hours (Ponchielli); Harlequin and Colombine (Kaskel); Serbian Potpourri (Petrovic); March (Petrovic). 6.55, Time; Programme Announcements. 7.0, Talk. 7.30, Announcements. 7.40, Records. 7.45, Talk. 8.15, Programme from Zagreb, 1,086 kc/s, 276.2 metres. 9.45, Records. 10.0, Time; News. 10.15, Concert from the Domovina Restaurant. 10.50, Records. 11.0, Close Down.

BERLIN

DEUTSCHLANDSENDER, 191 kc/s, 1,571 metres; 60 kW.—5.45 a.m., Weather. 5.50, News. 6.0, Gym. 6.15, Motto. 6.20, See **Hamburg**. In the interval at 7.0, News. 8.0, Interval. 8.45, Gym. for Women. 9.0, Löns Lieder. 9.40, Reading. 10.0, News. 10.10, Records in Broadcasting—A Peep behind the Scenes. 10.50, Games for Children. 11.15, Weather. 11.30, A Discussion for Women. 11.55, Weather. 12 Noon, See **Munich**. 12.55 p.m., Time. 1.0, Records of Spanish Music; Weather. 1.45, News. 2.0, Interval. 2.45, Greetings; Programme Announcements. 3.0, Weather; Exchange. 3.15, Talk: Frau Aja, Goethe's Mother. 3.40, Records. 4.0, See **Munich**. 5.30, Book Review. 5.45, Discussion: New German Films. 6.10, Modern Song Recital by Adolph Armhold: Five Songs (Knafl); (a) Schlafend trägt man mich, (b) Weisses Schaf, (c) Mich besingt die Zeit mit Schall, (d) Winterabend, (e) Das ist nicht Zeit; Five Songs (Pfitzner): (a) Lockung, (b) Das verlassene Mägdelein, (c) Leuchtende Tage, (d) Hast du von den Fischerkindern, (e) Frieden; Three Songs (Haas): (a) Die Schmitzerin, (b) Kuckuck und Schäferin, (c) Gutzgauchs Fall. 6.35, A Poem; Weather. 6.40, A Spook on the Roof—Adventure Play (Kasten). 7.10, Beethoven and Schubert Music by Ely Ney (Pianoforte); Thirty-two Variations in C minor (Beethoven); Sonata in A flat, Op. 110 (Beethoven); Extracts, Moments musicaux (Schubert); Impromptu in A flat, Op. 90 (Schubert). 8.0, Motto; News. 8.15, See **Frankfurt**. 8.55, Concert by the Station Orchestra; Conductor, Lindner; Soloist, Ely Ney (Pianoforte): Pianoforte Concerto in B flat (Mozart); Symphony in E (Goetz). 10.0, News; Sports Notes. 10.30, Topical Talk. 10.45, Weather. 11.0, See **Cologne**. 12 Midnight (approx.), Close Down.

BERLIN

FUNKSTADT, 841 kc/s, 356.7 metres; 100 kW.—6.0 a.m., Gym. 6.15, Weather; Prayer. 6.20, See **Hamburg**. In the interval at 7.0, News. 8.0, Gym. 8.20, Records; Announcements. 9.0, See **Berlin (Deutschlandsender)**. 9.40, Talk for Women: Old Bayreuth. 10.0, Weather; News. 10.10 to 10.25, Market

FRIDAY

SEPTEMBER THE TWENTY-EIGHTH

Prices. 11.25 to 11.30, Exchange. 12 Noon, Concert from **Hamburg**. In the interval at 12.30 p.m., Weather. 1.0, News. 1.15, Records of Russian Music. 2.0, News. 2.15, Recital by Irmgard Preiss (Soprano), Herbert Selimke (Pianoforte) and Edmund Josefak (Baritone). 3.0 to 3.20, Exchange. 4.0, See **Brestau**. 6.0, Announcements. 6.5, Book Review. 6.30, Chamber Music by Willy Steiner and Carl Bohm (Violins), Alfred Schattschneider (Cello) and Karl Rockström (Pianoforte); Dances for Violin and Piano forte: (a) Gavotte (Handel), (b) Minuet (Méhul), (c) Folk Dance (Weber); Diverso mento in G for Two Violins and Cello (L. Mozart); Silhuettes for Two Violins and Piano forte, Op. 9 (Juan). 7.0, Legal Talk. 7.10, Talk: German Lakes. 7.25, Echoes of the Day. 7.45, Political Review. 8.0, News. 8.15, See **Frankfurt**. 8.55, Recital of Paul Graener Songs by Walter Ludwig (Tenor), the Composer at the Piano forte. 9.30, Third Symphony in D flat (Bittner), by the Station Orchestra; Conductor, Otto Frickhoeffer. 10.20, News. 10.50, La Waltz Time—Concert by the Small Station Orchestra; Conductor, Willy Steiner: Abendsonne (Lanner); Siesta (Waldteufel); Two Waltzes (Dvorák); Herbststürzen (Löhrl); Orchester (Schömann). 11.30, Andreas Schüller Programme by Hans Helmut Weber. 12 Midnight, Close Down.

BERNE.—Relays **Beromünster**

BEROMUNSTER

556 kc/s, 539.6 metres; 60 kW.—12 Noon, Dance Music on Records. 12.29 p.m., Time; Weather; News. 12.40, Potpourris on Records. 1.25, Time; Weather; Exchange;

interval at 7.0, Time; News. 8.0, March Records. 8.40, Gym. for Women. 9.0, Time; News. 10.10 to 10.40, Talk: By Motor-Cycle through Spain. 11.30, Time; News. 12 Noon, Concert by the Bunzlau Municipal Orchestra; March (Blankenburg); Grieg Potpourri (Urbach); Gavotte from Idomeno (Mozart); Waltz, Wine, Woman and Song (Joh. Strauss). In the interval at 12.30, Time; Weather; and at 1.30, Time; News. 2.20, Exchange. 2.25, Post Office Propaganda; Records. 2.50, Market Prices. 3.10, Readings. 3.25, Kaun and Wolf Tenor Solos by Alfred Stöckel, with Commentary: Four Songs (Kaun): (a) Entelied, (b) Venedig, (c) Auf ein altes Bild, (d) Auf einer Wanderung; Four Songs (Wolf): (a) Verschwiezene Liebe, (b) Fussreise, (c) Der Musikant, (d) Der Genesende an die Hoffnung. 4.0, Concert by the Station Orchestra; Conductor, Rischka; Soloists, Margot Hasse (Violin) and Kurt Hattwig (Pianoforte); Overture in E minor (Nitschke); Rossini Potpourri (Respighi); Canzonetta (Bocherini); Waltz in D (Cramer); Wiegeliend (Reger); Capriccio (Reger); Festsche Musik (Koschinsky); Suite from Belshazzar (Sibelius); Romanian Melody (de Sarasate); Melody (Stojowsky); Allegretto tranquillo (Grieg); Prelude to Gaudemus (Humperdinck); Intermezzo; In Hammersbach (Elgar); Valse lento (d'Ambrosio); March (Gabetti). In the interval at 5.30, Weather; Market Prices. 5.50, Talk. 6.15, Programme for Young People: Scapa Flow—Sequence (Willy Rockow). 6.50, Programme Announcements; Weather; Market Prices. 7.0, Report from the Waterworks in Upper Silesia. 7.45, See **Berlin (Funkstunde)**. 8.0, News. 8.15 to 10.20, See **Frankfurt**. 10.20,

by Daisy Gilbert and Maria Goon. 7.30, Legal Talk and Literary Review. 8.0, Ex-Servicemen's Programme; Address; Recitations; Music. 9.15, Concert by the Symphony Orchestra; Soloist, José Pierre (Songs); Symphony No. 1 in B flat (Schubert); Songs: (a) Variations on Le carnaval de Venise (Benedict), (b) Aria from The Puritans (Bellini), (c) Song (Jonelli); Ballet Music from Rosamund (Schubert); Melodia (Schubert); Military Marches Nos. 3 and 4 (Schubert). 10.0, News. 10.10, Request Records. 10.25, Dance Music. 11.0, La Brabançonne.

BRUSSELS (No. 2)

532 kc/s, 321.9 metres; 15 kW. Programme in Flemish.—11.57 a.m., Weather. 12 Noon, Records. 1.0 p.m., News. 1.10, Popular Orchestral Music; Soloist, Olga Shamsheff (Songs to the Guitar); Marche jubilant (de Boeck); Waltz, Une journée à Séville (Waldteufel); Overture, Don Pasquale (Donizetti); Baby plays Soldier (de Micheli); Selection from The Three Musketeers (Friml); Songs; Cinema Suite (Ketelbey). 2.0, Interval. 4.55, Announcements. 5.0, Records: The Scottish Symphony (Meißelsolhn); Hungarian Dances Nos. 1, 2 and 3 (Brahms). 6.0, Records: Acts I and III from Fedora (Giordano). 6.45, Song Recital by Jacqueline De Kessel. 7.0, Talk: Economics. 7.15, Records: Extracts from the Sonata in D minor, Op. 45, for Violin and Piano forte (Grieg). 7.30, News. 8.0, Promenade Concert, relayed from **London**. In the interval at 9.35, Recitations. 10.30, News. 10.40, Dance Records. 11.0, Close Down.

BUCHAREST

823 kc/s, 364.5 metres; 12 kW.—12 Noon, Water Level; Records. 12.45 p.m., Amusement Guide; Exchange; Records of Light Music. 1.15, Time; Weather; News. 1.40, Records of Light Music. 5.0, Concert by the Station Orchestra: Overture, William Tell (Rossini); Country Suite (Amadei); Rusticiana (Cortopassi); Souvenir de Bidolia (Karastoyanoff); Aubade (d'Ambrósio); Noël Pastoral (Alberty); Idylle (Königsberger); Peasant Scenes (Smetana). 6.0, Time; Weather; News. 6.15, Concert by the Station Orchestra. 7.0, Educational Programme. 7.15, Talk. 8.0, Violin Recital of Italian Music by Sandu Albu: La Folia (Corelli); Concerto in E minor (Nardini); Minuet (Porpora); Allegretto (Bocherini); Prelude and Allegro (Pugnani). 8.30, Talk. 8.45, Song Recital by Florica Popovici; Le Rossignol amoureux (Rameau); Aria from The Magic Flute (Mozart); Elegy (Duparc); Nocturne (Fauré); Nicolette (Rayle); Two Romanian Folk Songs. 9.15, Pianoforte Recital by Illy Wechsler: Etude de Concert in G flat (Moszkowsky); Prelude in G sharp (Rachmaninov); The Flight of the Bumble Bee (Rim-sky-Korsakov); Etude (Scriabin); Idyll (Rogalski); Oriental Fantasy (Baškirev). 9.45, News.

BUDAPEST

546 kc/s, 549.5 metres; 120 kW.—6.45 a.m., Gym. 9.45, News. 10.0, Talk. 10.40, Talk. 12 Noon, Chimes from the University Church. 12.5 p.m., Concert by the Szalay Cigány Band. 1.30, Orchestral Concert; Conductor, Fridl. 2.40, Hints for Housewives. 4.0, Handwork Lesson. 5.0, Report from a Mine. 5.50, Tárarog Recital by Imre Dobos. 6.30, Talk: National Economy Day. 7.5, Records. 7.45, Sports Notes. 8.0, A Comedy (Sardon and Najac). 9.45, News. 10.5, Concert by the Horváth Cigány Band. 10.30, Foreign News. 11.15, Pianoforte Recital by Takács.

CASSEL.—Relays **Frankfurt**.

COLOGNE

658 kc/s, 455.9 metres; 60 kW.—5.30 a.m., Motto; Records. 6.5, Gym. 6.25, Reading. 6.35, Request Records. 6.50 to 7.5, Time; Weather; News. 8.0, Time; Weather; Water Level. 8.5, Gym. for Women. 8.20 to 8.35, Talk: The Stepmother. 10.0, Time; News; Water Level. 10.10, Talk for Schools. 10.45, Talk with Records: The Melle District. 11.0, Chopin and Brahms Recital by Otti Kersten (Pianoforte) and Auguste Weller (Soprano); Pianoforte Solos (Chopin): (a) Nocturne in F Sharp Minor, (b) Prelude in D Minor; Soprano Solos (Brahms): (a) Die Mainacht, (b) Auf dem See; Ballade in F Minor for Pianoforte (Chopin). 11.30, Post Office Propaganda; Records. 12 Noon, Concert by the Station Chamber Quintet. 12.45 p.m., News; Greetings. 1.0 to 2.45, Concert by the Small Station Orchestra. In the interval at 1.45, News. 3.15, Talk: The Westphalian Iron Industry. 3.30, Exchange. 3.45, Book Review for Young People. 4.0, Concert by the Station Chamber Orchestra; Conductor, Hartmann; Prelude to Naktiris Hoehzeit (Lüncke); Waltz, Blonde or Brunette (Waldteufel); Delibes Potpourri (Urbach); Cherry Blossom (Albert); Piece (Alstyne); A-B-C Potpourri (Kozak); Russian Song and Dance Potpourri (Fetras). 5.0, Literary Talk. 5.15, Talk with Records; Scandinavian Folk Music. 5.45, Talk: Rhinish Place Names. 6.0, Music for Young People. 6.20, English Conversation. 7.0, Spinnstube—Folk Song Sequence (Hatzfeld); The Station Choir and Soloists; Conductor, Breuer. 7.45, Political Report. 8.0, News. 8.15, See **Frankfurt**. 8.55, Orchestral Concert; Conductor, Buschkötter; Soloist,

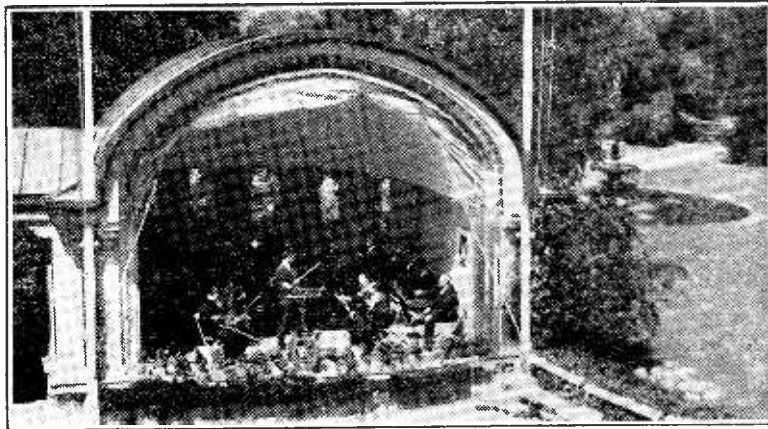

Mario Galli and his orchestra in the "Kungsparken" (King's Park) at Malmö. The orchestra is often heard over the Swedish network of more than 30 stations.

Interval. 3.30, Records. 3.59, Time. 4.0, Concert of Rocco Period Music. 4.55, Concert of Light Music by the Station Orchestra; Conductor, Neppach; Soloists, The Wildhaber Sisters (Songs). 6.0, Reading for Children. 6.30, Gardening Talk. 6.45, Six Folk Songs. 7.0, Time; Weather; Market Prices; Tourist Report; Sports Notes. 7.20, Talk. 7.50, Lobetanz—A Poem with Music. In the interval at 9.10 (approx.), Weather; News. 10.15 (approx.), News; Close Down.

BODEN.—Relays **Stockholm**. **BODO.**—Relays **Oslo**.

BRATISLAVA

1,004 kc/s, 298.8 metres; 15.5 kW.—6.39 a.m., See **Prague**. 8.30, Records. 9.10, Announcements. 9.15, Catholic Address. 9.30, See **Prague**. 11.0, See **Bрно**. 12 Noon, See **Prague**. 12.15 p.m., Concert by the Station Orchestra; Conductor, Dyk. 1.30, See **Prague**. 1.45 to 1.50, Water-Level. 4.0, Concert by the Station Orchestra, relayed from **Kosice**, 1,158 kc/s, 259.1 metres. 5.30, Talk: The Dead Sea. 5.45, Organ Recital by A. Ledyina. 6.10, Talk for Housewives. 6.15, Hungarian Transmission; Talk; Readings; Records. 6.55, See **Prague**. 7.40, Talk. 7.55, Recital of Slovak Folk Songs by St. Hoza (Tenor). 8.20, Recitations. 8.35, Violin Recital by J. Simon. 8.55, Act III of The Feast at Boleslav—Drama (Durych). 9.35, Recital of Russian Songs by B. Archipov. 10.0, See **Prague**. 10.45, News in Hungarian. 11.0, Close Down.

BREMEN.—Relays **Hamburg**.

BRESLAU

950 kc/s, 315.8 metres; 60 kW. Relayed by **Gleiwitz**, 1,231 kc/s, 243.7 metres.—5.0 a.m., Hymn; Motto; Records. In the interval at 5.40, Time; Weather. 6.0, Time; Weather; Gym. 6.25, See **Leipzig**. In the

Time; News. 10.45, Dance Music by the Station Dance Band; Conductor, Hlgenes. 12 Midnight (approx.), Close Down.

BRNO

922 kc/s, 325.4 metres; 32 kW.—6.30, See **Prague**. 8.45, Records. 8.55, Political Talk for Workers. 9.15, Violin Recital by Zamecnik. 9.30, See **Prague**. 11.0, Concert by the Station Orchestra and Moravian Teacher's Vocal Union; Conductor, Janota; Soloist, Walter. 12 Noon, See **Prague**. 12.15 p.m., See **Bratislava**. 1.30 to 1.45, See **Prague**. 4.0, Concert by the Station Orchestra, relayed from **Kosice**, 1,158 kc/s, 259.1 metres. 5.30, Talk. 5.45, Records. 5.55, German Transmission: The Broken Jug—Comedy (Kleist). 6.55, See **Prague**. 7.55, Song Recital by Příbyst'kov (Bass). 8.15, Extract from Saint Wenceslas (Durych), by Members of the National Theatre. 9.0, See **Moravská-Ostrava**. 10.0, See **Prague**. 11.0 (approx.), Close Down.

BRUSSELS (No. 1)

620 kc/s, 483.9 metres; 15 kW.—11.55 a.m., Weather. 12 Noon, Popular Orchestral Music; Soloists, Gilman (Flute), Durand (Tenor); March (Spael); Waltz, Les sirènes (Waldteufel); Overture, The Gipsy Baron (Joh. Strauss); Adoration (La Gye); Potpourri (Urbach); Souvenir de Spa for Flute (Maurice); Ideale (Tosti); Fantasia on Paganini (Lehár). 1.0 p.m., News. 1.10, Records. 2.0, Interval. 4.55, Announcements. 5.0, Dame Concert by the Symphony Orchestra; Marche cortège; Symphony in F; Caprice; Venetian Dancer; Bucolique; Seguidilla Valse Symphonique. 6.0, Talk. 6.15, Request Records. 6.30, Beethoven Recital by Jean Brennet (Pianoforte): Sonata in F Minor, Op. 2, No. 1; Sonata in A, Op. 2, No. 2. 7.0, Talk. 7.15, Musical Monologues

SEPT. 28th **FRIDAY** continued

Hoelscher (Cello): Prelude to Die Geschöpfe des Prometheus (Beethoven); Cello Concerto in A Minor (Schumann); Variations, Enigma (Elgar). 10.0, Time; News. 10.20, Theatre Talk. 11.0, Dance Music by the Leo Eysoldt Dance Band. 12 Midnight, Close Down.

COPENHAGEN.—Relays Kalundborg. **CORK.**—Relays Athlone. **DANZIG.**—Relays Königsberg. **DRESDEN.**—Relays Leipzig.

FECAMP

1,456 kc/s, 206 metres; 10 kW.—11.30 a.m. to 12 Noon, Programme in English arranged by the International Broadcasting Company of London; Happy Half-Hour; Request Programme. 12 Noon, Programme in French. 4.30 p.m. to 6.0, Programme in English arranged by the I.B.C. (London). 4.30, Concert; Dance Music. 5.0, Bournemouth, Weymouth, Southampton and Winchester Concert; Part 1, Patrick Waddington. 5.30, Part 2, Orchestral Music. 6.0, Programme in French. 11.0 till Close Down, Programme in English arranged by the I.B.C. (London). 11.0, Talkie Time; Times from the Talkies and Shows. 11.35, Concert; Variety (on Gramophone Records). 12 Midnight, Concert for Musselbong Listeners; Dance Music. 12.30 a.m. (Saturday), I.B.C. Time Signal. 12.31, Dance Music. 1.0 a.m., I.B.C. Good-night Melody and Close Down.

FLENSBURG.—Relays Hamburg. **FLORINCE.**—Relays Milan.

FRANKFURT

1,195 kc/s, 251 metres; 17 kW.—5.45 a.m., Hymn; Time; Weather. 5.50, Gym. 6.40, Time; News. 6.50, Weather. 6.55, Orchestral Concert; Conductor, Hoffmann. 8.10, Water Level; Weather. 8.15 to 8.35, Gym. 10.0, News. 10.45, Hints for Housewives. 11.0, Announcements; Records. 11.30, Announcements; Exchange; Weather. 11.45, Social Notes. 12 Noon, See Munich. 1.0 p.m., Time; News. 1.10, Local News. 1.20, See Stuttgart. 1.50, Time; News. 2.0, See Stuttgart. 2.30, Economic Report. 2.45, Time; Exchange. 2.55, Weather. 3.10, Programme for Women. 4.0, See Stuttgart. 5.30, Talk: Peasant Stock. 5.45, Chopin Pianoforte Recital by Ada Turana: Prelude in D Flat; Ballad in G Minor. 6.0, Programme for Young People: Prince Eugene—Sketch (Dieter Bassermann). 6.25, Talk: Astronomy. 6.45, Weather; Exchange; Announcements; Time. 6.50, Concert by the Trier Municipal Orchestra; Conductor, Creutzburg; Overture, The Hermit's Bell (Maillart) Peer Gynt Suite No. 1 (Grieg); Prelude to Hansel and Gretel (Humperdinck); Kaiser-Walzer (Joh. Strauss); Slav Rhapsody (Friedemann); Overture, Bandenstreich (Suppé). 7.45, See Berlin (Funkstunde). 8.0, News. 8.15, Transmission for all German Stations: The Tannus in Autumn—Sequence. 8.55, Concert by the Station Orchestra and Choir with Franz Hauke (Saxophone); Conductor, Belker; Overture, Berliner Luft (Lincke); Choir and Orchestra: Waltz, Wiener Blut (Joh. Strauss); Selection from The Merry Widow (Lehár); Choir and Orchestra: Waltz, Roses from the South (Joh. Strauss); Potpourri, Münchner Leben (Pollak). In the interval, a Sketch. 10.20, Time; News. 10.35, Local News; Weather; Sports Report. 10.45, Sports Review. 11.0, Spirits of the Rhine—Hildegard von Bingen and Casarius von Heisterbach. 12 Midnight, Johann Strauss Concert by the Station Orchestra; Conductor, Rosband; Overture, Eine Nacht in Venedig; Waltz from Jabuka; Egyptian March; Waltz, Wine, Woman and Song; Annen Polka; Waltz, Morgenblätter; Polka-Mazurka, Der Klügere gibt nach; March from The Gipsy Baron; Waltz, The Blue Danube. 1.0 a.m. (Saturday), Close Down.

FREDRISSTAD.—Relays Oslo. **FREIBURG.**—Relays Stuttgart. **GENEVA.**—Relays Sottens. **GENOA.**—Relays Milan. **GLEIWITZ.**—Relays Breslau. **GÖTEBORG.**—Relays Stockholm. **GRAZ.**—Relays Vienna. **HAMAR.**—Relays Oslo.

HAMBURG

904 kc/s, 331.9 metres; 100 kW. Relayed by Bremen, Flensburg, and Hanover, 1,330 kc/s, 225.6 metres.—5.45 a.m., Time; Weather; Notes for Farmers. 6.0, Gym. 6.15, Time; Weather. 6.20 (from Kiel), Orchestral Concert; Conductor, Döring. In the interval at 7.0, Time; News. 8.0, Weather; Talk for Housewives. 8.10, Announcements; Records. 10.50, News. 11.0, Play for Schools. 11.30 (from Bremen), Concert by Fredo Niemann's Wind Instrument Orchestra from the Town Hall: March (Teike); Hungarian Comedy Overture (Keler-Bela); Waltz (Fétras); Serenade (Brase); Selection from Eugene Onegin (Tchaikovsky); March (Umrath); Zigeunerstäubechen (Nehú); Selection from Gasparone (Müllacker); Intermezzo, Sefira (Siede); March (Bruttsch). In the interval, Report for Housewives; Time; Announcements. 1.0 p.m., Exchange. 1.15, Weather. 1.20, Musical Programme. 2.15, News. 2.30, Records; Russian Music. 3.0, Exchange. 3.40, Shipping and Aviation Notes. 4.0, See Königsberg. 5.30, Reading. 5.45, Programme for Young People. 6.0, Wilhelm Plog Programme. 6.45, Exchange. 6.55, Weather. 7.0 (from Flensburg), Shock-headed Peter—Choral Sequence Op. 28 (Fritz Reuter); Orchestra and Women's Choir; Conductor,

Röder; Soloist, Gertrud Trenkrog (Harpischord). 7.45, See Berlin (Funkstunde). 8.0, News. 8.15, See Frankfurt. 8.55, Character Test—Musical Play (Siegfried Scheffler); The Station Orchestra and Soloists; Conductor, Seeker. 10.0, News. 10.20, Musical Programme. 11.0 (from Flensburg), from the Deutsche Hans. Orchestral Concert; Conductor, Röder; Rakoczy Overture (Keler-Bela); Meditation on Thais (Massenet); Paraphrase on the Song, Aus der Jugendzeit (Friedemann); Pusztá-Ritt (Hagspiel); Selection from La Poupée (Audran); Waltz, Les Sirènes (Waldteufel); March (von Blon). 12 Midnight (approx.), Close Down.

HANOVER.—Relays Hamburg.

HILVERSUM

160 kc/s, 1,875 metres; 7 kW. (until 3.40 p.m.). Transmitted on Kootwijk, 50 kW. from 3.40 p.m.—7.40 to 9.40 a.m., Programme of the Workers' Radio Society (V.A.R.A.). Records. 9.40, Religious Programme of the Liberal Protestant Radio Society (V.P.R.O.). 9.55 to 11.40, V.A.R.A. Programme. 9.55, Recitations. 10.10, Organ Recital by Steyn. 10.40, Recitations (cont'd.). 10.55, Songs and Instrumental Music. 11.40 to 3.40 p.m., Programme of the General Broadcasting Society (A.V.R.O.). 11.40, Time; Records. 12.10 p.m., Concert of Light Music by the Rentmeester Orchestra. In the interval, Records. 1.50, Dressmaking Lesson. 2.10, Pianoforte Recital by Willem van der Aelst: Sonata quasi una fantasia, Op. 27, No. 2 (Beethoven); Mazurka, Op. 68, No. 2 (Chopin); Eight Waltzes, Op. 39 (Brahms); (Chopin); Nocturne, Op. 15, No. 2. 2.40, Records. 3.43 to 7.40, V.A.R.A. Programme. 3.43, Dressmaking Lesson. 4.25, Records. 4.40, Programme for Children. 5.10, Orchestral Concert of Light Music; Conductor, Wins. 5.40, Concert by the Small V.A.R.A. Ensemble: Overture, Gri-Gri (Lincke); Piece (MacDowell); Waltz No. 1, Op. 54 (Dvorák); Stelldichein mit Columbine (Heykens); Intermezzo (Hellmesberger); Folly Dance (Haines). 6.10, Orchestral Concert of Light Music; Conductor, Horst. 6.40, Organ Recital by Jong: Selection from Rigoletto (Verdi); Did you ever see a Dream walking? (Revel); Serenade (Heykens); Speak to me of Love (Lenoir); Es ist kein Zufall (Stolz). 7.10, Talk. 7.30, Records. 7.37, S.O.S. Announcements. 7.40 to 10.40, V.P.R.O. Programme. 10.40 till Close Down, V.A.R.A. Programme of Records. 11.40 (approx.), Close Down.

HORBY.—Relays Stockholm.

HUIZEN

955 kc/s, 301.5 metres; 7 kW. (until 6.40 p.m.), 20 kW. from 6.40 p.m.—7.40 a.m. till Close Down, Programme of the Christian Radio Society (N.C.R.V.). 7.40, Bible Reading; Prayers. 7.55, Records. 9.10, Interval. 10.10, Religious Address. 10.40, Concert by the Van der Horst Ensemble. In the interval at 11.40, Police Notes; Records. 1.10 p.m., Organ Recital by Visser: Au matin (Godard); Berceuse (Godard); Gavotte (Niemann); Gavotte (Corelli); Piece (Voss); Four Songs without Words (Mendelssohn); Fantasia (Visser); Piece (Simon); Serenade (Heykens); Spanish Dances Nos. 1 and 2 (Moszkowsky); Improvisation (Visser). 2.10, Reading. 2.40, 'Cello Recital by Werner: Suite in D (d'Hervelois); Sonata in A Minor (Galliardi); Records; Sonata (Corelli). 3.25, Interval. 3.40, Records. 4.40, Recital by Mme. A. de Vink-Verschoor (Soprano), Smulders (Tenor), Stoty (Oboe), and Schellevis (Pianoforte). 6.10, Talk. 6.40, Police Notes; Church News. 6.55, Records. 7.10, Literary Talk. 7.40, Concert by a Double Male Voice Quartet; Conductor, Vischer; Soloist, Bouwmeester (Organ); Beati Mortui (Mendelssohn); Nimmer Nacht (Andriessen); Meditation for Organ (Martin); Piece (Faulkes); Prayer and Lullaby (Guilman); Sanctus (Schubert); Die Vesper (Beethoven); Piece (Wierts); Four Pieces for Organ (Bouwmeester): (a) Melody, (b) The Flute, (c) Songs, (d) Improvisation. 8.40, Talk. 9.10, Concert for String Orchestra; Soloists, Stoghem and Vonk (Violin) and Mlle. Lankhant (Pianoforte); Concerto in D Minor for Two Violins and Orchestra (Bach); Pianoforte Concerto in A (Mozart); Symphony in E Flat (Haydn). In the interval at 9.30, Press Review. 10.40, Records. 11.10, Close Down.

INNSBRUCK.—Relays Vienna.

KALUNDBORG

238 kc/s, 1,261 metres; 75 kW. Relayed by Copenhagen, 1,176 kc/s, 255.1 metres; and Skamlehøek, 49.5 metres.—7.0 a.m., Gym. 8.30, Divine Service from Copenhagen Cathedral. 10.15 to 10.45, Natural History Talk for Schools. 11.0, Weather. 11.10, Fish Prices. 12 Noon, Time; Chimes. 12.2 p.m., Concert by the Bendix String Ensemble, relayed from the Wivex Restaurant. 2.0, Interval. 2.40, Concert by Carl Rydahl's Instrumental Ensemble: Overture, The Bohemian Girl (Balfe); Minuet in E (Mozart); Waltz, Passage d'automne (Waldteufel); Selection from The Daughter of the

Regiment (Donizetti); Minuet and Gavotte from Manon (Massenet); Dance from Weyland the Smith (Henriques); Classic Minuet (Rijs-Magnussen); Valse lento (Dolfi); Mattinata (Leonecavallo); Fantasia on Swedish Folk Songs and Dances (Eysden); The Wedding of the Rose (Jessé); Pepita Polka (Lumbye); March (Ryning). In the interval at 3.30, Reading (Sick). 4.40, Play with Songs for Young People. 5.30, Exchange; Fish Market Prices. 5.45, Talk. 6.15, Elementary German Lesson. 6.45, Weather. 6.54, Announcements. 7.0, News. 7.15, Time. 7.16, Talk relayed from the University; The Layman and the Law. 8.0, Time. 8.1, Review, by Per Kuntzon. 8.10, Harp Recital by Maria Korchińska: Extracts from the Suite for Harp (Rameau); Impromptu (Ronsse); Fantasia (Saint-Saens). 8.30, Song's Big Prize—Tragi-Comedy in Three Acts (Juschkewitsch), translated by Kalekar. 9.30, Song Records. 9.40, A Visit to Hillerød Castle. 10.10, News. 10.25, Chamber Music by Hye-Knudsen (Flute), Henriques (Violin), Adda Varnung (Viola), Duet for Flute and Violin (C. P. E. Bach); Serenade in G. Op. 141 (Reger). 10.55, Dance Music from the Ritz Restaurant. In the interval at 12 Midnight, Time; Chimes. 12.30 a.m. (Saturday), Close Down.

KIEL.—Relays Hamburg. **KLAGENFURT.**—Relays Vienna.

KONIGSBERG

1,031 kc/s, 291 metres; 60 kW. Relayed by Danzig, 1,303 kc/s, 230.2 metres.—5.0 a.m., Records. 5.50, Weather. 6.0, Gym. 6.20, See Hamburg. In the interval at 7.0, News. 8.0, Prayers. 8.30 to 9.0, Gym. for Women. 9.5 (from Danzig), French Lesson for Schools. 10.40, News. 11.30, See Hamburg. 1.1 p.m., Time; Weather. 1.5, Records. In the intervals at 1.20 and 2.0, News. 2.30, Announcements; Records. 3.0, Exchange. 3.15, Handwork Lesson for Children. 3.40, Programme for Women. 4.5, Concert by the Small Station Orchestra; Conductor, Wilken: Overture, Hunyadi László (Erkel); Selection from Thais (Massenet); Gipsy Festival (Heykens); Serenata (de Micheli); Suite, Ein Schubertabend in Wien (Ralf); Waltz from The Arabian Nights (Joh. Strauss); In the Village (Tchaikovsky); Humoresque (Tchaikovsky); Selection from Le Roi d'Yvetot (Adam). 5.30, Soprano Song Recital by Käthe Corandae-Laechelin; Willst du dein Herz mir schenken (Bach); Ancora (Lotti); La Violetta (Scarlatti) (Perzolesi); Schwand des Tages Pracht (Glück) Wiegenlied (Mozart). 5.50, Talk: Salmon Fishing in East Prussia. 6.15, Market Prices. 6.25, Programme for Young People. 6.55, Weather. 7.0, Concert by the Small Station Orchestra; Conductor, Wilken: March (Schrammel); Overture, Light Cavalry (Suppé); Jetzt wird gemütlich (Leuschner); Amoretteingeigen (Fucik); Waltz, Gold and Silver (Lehár); Auf der Lüneburger Heide (Blume); Vom Rhein der Wein (Lincke). 7.45, See Berlin (Funkstunde). 8.0, News. 8.15, See Frankfurt. 8.55, Concert by the Opera House Orchestra; Conductor, Lorber; Soloist, Schröder (Violin); Kleist Overture (Wetz); Violin Concerto in D (Brahms); Les Préludes (Liszt). 10.0, News. 10.30, Dance Music by the Erich Börschel Jazz Band. 12.30 a.m. (Saturday), Close Down.

KOSICE.—Relays Prague. **LAUSANNE.**—Relays Sottens.

LEIPZIG

785 kc/s, 382.2 metres; 120 kW. Relayed by Dresden, 1,285 kc/s, 233.5 metres.—5.50 a.m., Report for Farmers. 6.0, Gym. 6.25, Concert by the EmDe Orchestra. In the interval at 7.0, News. 8.0, Gym. 8.20, Records. 9.0, See Berlin (Deutschlandsender). 9.40, Exchange. 9.45, Announcements. 11.0, Announcements; Records. 11.30, News; Time. 11.40, Weather. 11.45, Programme for Farmers. 12 Noon, Johann Strauss Records. 1.0 p.m., News. 1.10, Concert by the Halle Chamber Orchestra; Conductor, Zschiesing. In the interval at 2.0, News; Exchange. 2.40 to 3.0, Programme for Women. 3.15, Talk: Old Germanic Peasant Culture. 3.35, Exchange. 4.0, See Cologne. 5.0, Songs by a Boys' Choir. 5.20, Niemann Pianoforte Recital by the Composer: Twelve Kocheler Ländler, Op. 135; Suite, Op. 71. 5.50, Exchange; Weather; Time. 6.0, Talk: With the Volunteer Corps in the Baltic in 1919. 6.20, Working Men and Women describe their State-subsidised Holidays. 6.40, Military Band Concert; Conductor, Bier. 7.45, See Berlin (Funkstunde). 8.0, News. 8.15, See Frankfurt. 9.0, Concert by the Leipzig Symphony Orchestra; Conductor, Weisbach; Soloist, Friedrich Wührer (Pianoforte); Pianoforte Concerto No. 2 in G minor, Op. 15 (Rachmaninov); Symphony No. 2 in D, Op. 43 (Sibelius). 10.20, News; Sports Notes. 10.50, Dance Music from Königsberg. 12.30 a.m. (Saturday), Close Down.

LINZ.—Relays Vienna.

LUXEMBOURG

230 kc/s, 1,304 metres; 150 kW.—7.45 a.m., Records. 8.0, News in French; Record; News in German; Record. 12 Noon, Concert by the Station Orchestra; Conductor, Pensis; Overture, Post and Peasant (Suppé); Kind, Du kannst tanzen (Fall); Indian Love Lyrics (Woodford-Pinden); Piece (Valisi). 12.30 p.m., News in French and German. 12.40, Concert (cont'd.); Two Pieces for Trio (Pierne); (a) Vision d'Orient, (b) Enchantment; Slav Dance No. 10 (Dvorák); Suite orientale (Popy). 1.0, Exchange. 1.5, Concert (cont'd.); Wedgwood Blue (Kettelbey); Piece (Macbeth); Piece (Allbrocht). 1.15, Records. 1.30, Exchange. 1.35, Records. 2.0, Exchange. 3.45, Exchange. 6.30, Concert of Light Music and Dance Music. 7.30, Racing Results. 7.35 till Close Down, Dutch Evening. 7.35, Violin Recital by René Mertzling; Elegie (Caplet); Two Movements from Concerto No. 4 in D minor (Viennytemp); Finale from Concerto No. 2 in D minor (Wieniawski). 8.0, News in French and German. 8.20, Concert by the Station Orchestra; Conductor, Pensis; Overture, Casanova (Lincke); Moonlight on the Alster (Fétras). 8.35, Exchange. 8.40, Concert (cont'd.); Selection from Mignon (Thomas); Polchinnelle (Daneau); Song (Amadié); Piece (Ciére); Suite pour mes petits Amis (Pierne); Liebeslied (Kreislter); Rhapsody No. 2 (Liszt). 9.30, Concert. 9.50, Song Recital by Venant Pauk (Baritone); Aria from Opera de Stambul (Trémisot); Aria from Quo Vadis (Nougnes); Aria from La Danseuse de Tanagra (Hircchmann); Song from Dances of Death (Musorgski). 10.25, Dance Music by the Station Dance Band; Conductor, Jouza.

MADRID

(EAJ7), 1,095 kc/s, 274 metres; 7 kW.—9.0 a.m., News. 10.0 to 10.30, Exchange; Announcements. 2.0, Chimes; Weather; Light Music. 2.30, Concert by the Station Sextet. 3.0, Amusement Guide; Exchange; Variety Music. 3.30, Concert by the Station Sextet. 4.0, News; Variety Music. 4.30, Concert by the Station Sextet. 4.50, News. 5.0, Interval. 6.0, Chimes; Light Music. 7.0, Announcements. 7.10 (approx.), Opera Music; Dance of the Hours from La Gioconda (Ponchielli); Ballet Music from Faust (Gounod); Egyptian Ballet from Aida (Verdi); Dances from Prince Igor (Borodin). 7.30, Exchange; Music of the Asturias. 8.0 News. 8.10 (approx.), Concert by a Quartet of Spanish Instruments. 8.40 (approx.), Programme for Women. 9.40, Sports Notes. 10.0, Chimes; Song Recital by Hilario Azcona (Baritone). 11.0, News. 11.10 (approx.), Concert by the Station Sextet. 11.30, Relay from a Theatre. 12.45 a.m., (Saturday), News. 1.0, Chimes; Close Down.

MALMO.—Relays Stockholm.

MILAN

814 kc/s, 368.6 metres; 50 kW. Relayed by Turin, 1,140 kc/s, 263.2 metres; Genoa, 986 kc/s, 304.3 metres; and Florence, 610 kc/s, 491.8 metres.—7.30 a.m., Gym. 7.45, Time; News. 11.30, Concert by the Chesi-Zanardelli-Cassone Trio. 12.30 p.m., Records. 12.45, News. 1.0, Time; News. 1.5 to 2.15, Concert by the Ferruzzi Orchestra. In the interval at 1.30, Records; Exchange. 2.15 to 2.25, Exchange. 4.35, News. 4.45, Programme for Children. 5.0, Orchestral Concert; Conductor, La Rosa Parodi; The Scottish Symphony (Mendelssohn); Omaggio a Vivaldi (La Rosa Parodi); Suite (Pick-Mangiagalli); Selection from Oberon (Weber). 5.55, Weather. 6.0 to 6.10, Programme for Farmers. 7.0, Announcements. 7.15, News in Foreign Languages. 8.0, Time; News; Records. 8.30, Government Notes. 8.45, The Dance of the Dragonflies—Operetta in Three Acts (Lehár); Conductor, Ricci. In the intervals, Talk; Literary Notes. After the Operetta, Dance Music. 11.0, News.

MONTE CENERI

1,167 kc/s, 257.1 metres; 15 kW.—12 Noon, Announcements; News; Concert by the Station Orchestra: Overture, La fanciulla della Asturie (Secchi); Selection from Le Postillon de Longjumeau (Adam); Elegy (Sohlström); Suite (Cassard); Song from The Flying Dutchman (Wagner). In the interval at 12.29 p.m., Time; Weather. 12.55, News. 1.5, Records. 1.30, Interval. 3.59, Time. 4.0 to 6.0, See Beromünster. 7.45, Announcements; News. 8.0, Talk on the following Transmission. 8.15, Symphony Concert; Conductor, Casella; Symphony in E Flat (Mozart); Military March (Schubert). 8.55, Talk: The Blue Danube. 9.5, Viennese Waltzes by the Station Orchestra; Pesterwalzer (Lanner); Herbstrosen (Joh. Strauss); Wine, Woman and Son (Joh. Strauss). 9.30, Popular Tyrolese Music. 10.0, Close Down.

MORAVSKA-OSTRAVA

1,158 kc/s, 259.1 metres; 11.2 kW.—6.30 a.m., See Prague. 11.0, See Brno. 12 Noon, See Prague. 12.15 p.m., See Bratislava. 1.30 to 1.45, See Prague. 4.0, Concert by the Station Orchestra, relayed from Kosice, 1,158 kc/s, 259.1 metres. 5.30, Reading and Recitations. 5.50, Record. 5.55, German Transmission; Programme for Children; Talk. 6.55, See Prague. 7.55, See Brno. 9.0, Concert by the Sokol Vocal Union; Conductor, Hradil. 9.30, St. Wenceslas

SEPT. 28th **FRIDAY** continued

(Kricka) by the Station Orchestra; Conductor, Musil. 10.0, See Prague. 11.0 (approx.). Close Down.

MOSCOW (No. 1)

174 kc/s, 1,724 metres; 500 kW.—5.0 a.m., News. 5.15, Fanfare. 5.45, Gym. 6.15, Musical Programme. 8.15, Programme for Children. 9.0, Musical Programme. 9.58, Time. 10.0, News. 10.15, Concert for Collectivist Farmers. 10.1, Programme Announcements. 3.15, Programme for Children. 3.58, Time. 4.0, News. 4.30, Communist Party Programme. 5.30, Red Army Programme. 8.0, Symphony Concert; Soloist, Abramov (Bass). 9.0, Talk in Czech: The Children's Museum. 9.55, Chimes. 10.5, Talk in English: The Seventieth Anniversary of the First International. 11.5, Talk in German: The Seventieth Anniversary of the First International.

MOTALA.—Relays Stockholm. **MUH-LACKER**.—See Stuttgart.

MUNICH

740 kc/s, 465.4 metres; 100 kW. Relayed by Augsburg and Nürnberg, 1,267 kc/s, 236.8 metres.—6.30 a.m., Gym. 6.45, Motto; Records. 7.5, Programme for Young People. 7.15, Time; News. 7.25, Recital by Maria Walter (Soprano), Sofie Stöber (Mezzo-Soprano), Otto Hieli (Tenor), Lorenz Winkler (Baritone) and Richard Staab (Pianoforte). 9.50, Gym. for Women. 10.10, Graf Zeppelin, Soldier and Combatant—Sequence (Gerhard Niese) on Records. 10.55, Market Prices. 11.5, Programme for Farmers. 11.15, Time; News. 11.30, Post Office Propaganda; Records. 12 Noon, Concert by the Small Station Orchestra; Conductor, Kloss; Soloist, Adalbert Huber (Viola). 1.15 p.m., Time; News. 1.25, Records. 2.0, News. 2.20, Reading. 2.50, Programme for Women. 3.30, Sports Talk: Hanns Braun. 3.50, Weather; Programme for Farmers. 4.0, Concert by the Small Station Orchestra; Conductor, Kloss. 5.30, Talk by a Member of the German East Africa Expedition, 1934. 5.50, Divertimento for Pianoforte, Flute, Oboe, Clarinet, Horn and Bassoon (Joun). 6.10, Talk: Cancer Research. 6.30 (from Nürnberg), Holiday Hints. 6.50, Time; Weather; Programme for Farmers. 7.0 (from Nürnberg), Concert by the Small Symphony Orchestra; Conductor, Köhler. 7.45, See Berlin (Funkstunde). 8.0, News. 8.15, See Frankfurt. 8.55, Concert by the Station Orchestra; Conductor, Winter; Soloist, Elizabeth Waldenau (Contralto). 9.35, Variety Programme by Charlotte Radspieler (Commentary), Altblühölzl (Guitar), Hilde (Tenor), Rückenschuss and Uli Schmidt (Violins) and Schmidmeier (Pianoforte). 10.0, Time; News. 10.20, Programme to be announced. 11.0, See Hamburg. 12 Midnight, Close Down.

NAPLES.—Relays Rome. **NOTODDEN**.—Relays Oslo.

OSLO

260 kc/s, 1,154 metres; 60 kW. Relayed by Hamar, 519 kc/s, 578 metres; and Jeløy, 6,990 kc/s, 42.92 metres.—10.0 a.m., Butter Prices. 11.15, Service. 11.50, Exchange. 12.55 p.m., Nauen Time Signal. 1.0, Records. In the intervals at 1.15, Weather; Talk for Farmers; and at 1.45, Exchange. 2.0, Market Prices. 5.0, Records. 6.0, Talk. 6.30, English Lesson. 6.50, Talk for Farmers. 7.0, Announcements. 7.15, Weather; News. 7.30, Time. 7.31, The Seventh Scandinavian Music Festival—Finland; The Philharmonic Orchestra; Conductor, Schneevogt; Symphony (Sibelius); Fantasia for Cello and Orchestra (Klamy); Concertino for Chamber Orchestra (Ranta); Ballet Suite from Okon Fuoko (Madetoja); Concerto No. 4 for Pianoforte and Orchestra (Palmgren); Andante elegiaco (Linnala); Prelude and Fugue on a Theme of Robert Kajanus (Merikanto); Symphonic Overture (Kajanus). 9.40, Weather; News. 10.0, Talk. 10.15, Literary Programme. 10.45, Close Down.

OSTERSUND.—Relays Stockholm.

PARIS

POSTE PARISIEN, 959 kc/s, 312.8 metres; 100 kW.—7.10 a.m., Fanfare; Records. In the intervals, News. 8.0 to 8.20, Concert. 8.45, Cookery Hints. 12 Noon, Exchange. 12.5 p.m., Records. 12.25, News. 12.35, New Records. 1.5, Exchange. 1.15, Records. 2.0, Exchange. 3.15, Exchange. 3.45, Exchange. 6.45, Exchange. 6.49, Notes for Farmers. 6.50, Talk. 6.58, Records of Czech Music. 7.10, News. 7.30, Records. 7.50, Humorous Records. 8.0, Interval. 8.10, Le Déluge—Biblical Opera (Saint-Saëns) by the Station Orchestra, Choir and Soloists; Conductor, Mathien. 10.20, News; Exchange. 10.30 till Close Down, Programme in English arranged by the International Broadcasting Company of London. 10.30, Concert; Records. 11.0, I.B.C. Goodnight Melody; Close Down.

PARIS

RADIO-PARIS, 182 kc/s, 1,648 metres; 75 kW.—6.45 a.m., Gym. 7.0, Records. 7.15, News. 7.45, Gym. 8.0, Records of Light Music. 12 Noon, Jewish Address. 12.30 p.m., Concert of Light Music by the Lucien Goldy Orchestra; Soloist, Jean Sorbier (Song Refrains). In the interval at 1.20, Exchange. 3.45, Exchange. 6.20, Announcements; Talk; Exchange; Racing Results.

6.50, Talk: Hunting. 7.0, A Dialogue. 7.25, Social Assurance Societies' Report. 7.30, Topical Talk. 8.0, Reading by Pierre Asso. 8.30, News. 8.45, Three Plays: (a) An Evening in Sorrento (Turgeniev), (b) La folle journée (Mazeaux), (c) Le renard et la grenouille (Sacha Guitry). In the interval at 9.15, Talk: Diabetics. 10.30, Dance Music by the Adolph Band.

PITTSBURGH

KDKA, 980 kc/s, 306 metres; 50 kW. Relayed by **W8XK** on 48.86 metres, and **25.27 metres**.—3.0 p.m., Edward MacHugh. 3.15, Sammy Fuller. 3.30, Today's Children. 3.45, News; Cookery Hints. 4.0, Marine Band Shut-in-Hour. 5.0, Fields and Hall. 5.15, Charles Sears. 5.30, Vic and Sade. 5.45, Hotel William Penn Orchestra. 6.0, Exchange. 6.15, Honourable Archie and Frank. 6.30, Farm and Home Hour. 7.30, KDKA Home Forum. 8.0, Gale Page. 8.15, Visit Foreign Village. 8.30, Little Concert Hall. 9.0, Betty and Bob. 9.15, Karen Pladoes. 9.30, Exchange. 9.45, Armchair Driver. 10.0, Orchestra. 10.15, KDKA Kiddies' Klub. 10.30, The Singing Lady. 10.45, Orphan Annie. 11.0, Dan and Sylvia. 11.14, Baseball Resume. 11.30, Comedy Stars of Hollywood. 11.45, Lowell Thomas. 12 Midnight, Amos 'n' Andy. 12.15 a.m. (Saturday), Sleepy Hall's Orchestra. 12.30, Nancy Martin. 12.45, News; Drama; Music. 1.0 to 6.0, Popular Programme.

PORSGRUND.—Relays Oslo.

PRAGUE

638 kc/s, 470.2 metres; 120 kW.—6.30 a.m., Gym.; Music; News. 7.0, Promenade Concert from Karlsbad. 8.30, Talk. 8.45, Records. 8.55, Talk for Workers. 9.15, Records. 9.30, Mass from St. Guy's Cathedral. 10.30, Literary Talk: St. Venceslas. 11.0, See Brno. 12 Noon, Chimes; News. 12.15 p.m., See Bratislava. 1.30 to 1.45, Talk for Farmers. 4.0, Orchestral Concert from Kosice, 1,158 kc/s, 259.1 metres.—5.30, Reading. 5.45, Records. 5.55, German Transmission: Concert by a Viennese Quartet: String Quartet in D (Mozart); String Quartet in C sharp minor (Beethoven). 6.55, News and Weather in German. 7.0, News; Weather. 7.5, St. Venceslas in Poetry, Prose and Drama—A Sequence. 7.40, Reading. 7.55, Introductory Talk on the following Transmission. 8.0, Concert by the St. Venceslas League, relayed from the Smetana Concert Hall. 10.0, Time; News. 10.15, Records. 10.45, Russian News. 11.0, Close Down.

RJUKAN.—Relays Oslo.

ROME

Call TRO, 713 kc/s, 420.8 metres; 50 kW. Relayed by Naples, 1,104 kc/s, 271.7 metres; **Milan No. 2**, 1,348 kc/s, 222.6 metres; **Turin No. 2**, 1,357 kc/s, 221.1 metres; and **TRO**, 11,810 kc/s, 25.4 metres.—7.30 a.m., Gym. 7.45 to 8.0, Time; News. 12.30 p.m., Records. 1.5 to 2.15, See Milan. In the interval at 1.30, Time; News. 4.30, Children's Radio Review. 4.55, News; Exchange. 5.10, Concert of Light Music: Festa a Siviglia (Seasola); Serenade (Montanaro); Selection from Adriana Lecouvreur (Cilea); Gipsy Song (Rossi); Selection from The Merry Widow (Lehár); Danza dei gnomi (de Micheli); Piece (Gilbert); Serenade, Tanganilla (Bazzani); Selection from Sicilian Vespers (Verdi); Foxtrot (Nissim). 5.55, Weather. 6.0, Wheat Market Prices. 6.10, Religious Talk. 7.0, Announcements. 7.15, News in Foreign Languages. 8.0, Time; News. 8.10, Records. 8.30, Government Notes. 8.45, Concert of Modern Symphony Music; Symphony in D (Prokofiev); Extract from Le Concert sur Peau (Casella); I piccoli soldati (Piek-Mangiagalli); Air from The Fire Bird (Stravinsky); Air from Petrushka (Stravinsky). 10.0, Variety. 10.30 (approx.), Dance Music. 11.0, News.

RUYSSELEDE

10,330 kc/s, 29.04 metres; 8 kW.—7.45 p.m., News in French. 8.0, Part Relay of the Promenade Concert from London. 8.52, Overture, Oberon (Weber-Godfrey) on Records. 9.0, News in Flemish. 9.15, Close Down.

SALZBURG.—Relays Vienna.

SCHENECTADY

WGY, 790 kc/s, 379.5 metres; 50 kW. Relayed at intervals by **W2XAF** on 31.48 metres and by **W2XAD** on 15.56 metres.—7.0 p.m., Will Audrey—Wandering Minstrel. 7.30, Woman's Radio Review; Talks; Orchestra. 11.25, Exchange. 12 Midnight, Cities Service Concert; Jessica Dragonette. 12.30 a.m. (Saturday), WGY Farm Forum. 1.0 to 3.0, Popular Programme.

STOCKHOLM

784 kc/s, 426.1 metres; 55 kW. Relayed by **Boden** and **Ostersund**, 413.5 kc/s, 726 metres; **Göteborg**, 941 kc/s, 318.8 metres; **Hörby**, 1,131 kc/s, 265.3 metres; **Motala**, 216 kc/s, 1,389 metres; and **Sundsvall**, 601 kc/s, 499.2 metres.—7.20 a.m., Gym. 7.45, Service. 8.0,

Weather. 12.30 p.m., Weather. 12.45 p.m., Exchange. 12.55, Time. 1.0, Concert relayed from **Lundborg**. 2.0, Talk. 2.30, Sonata No. 42 in A for Pianoforte and Violin (Mozart) on Records. 2.45 to 3.5, Talk: Life in a Danish School. 5.0, Weather. 5.5, Accordion Recital by Carl Gylling and Axel Ander. 5.30, Reading from L'Anneau d'Améthyste (Anatole France). 6.0, Records. 7.0, Weather Review. 7.15, Weather; News. 7.30, Talk: Birds. 7.50, Bach and Purcell Concert; Eta Harich-Schneider (Cembalo). Kerstin Lindberg-Torild (Songs), and Karl Achatz (Flute): Suite in G for Cembalo (Purcell); Songs: (a) When I am laid in Earth (Purcell), (b) Komm in mein Herzenhaus (Bach), (c) Höchster, was ich habe (Bach); Sonata in C for Flute and Cembalo (Bach); Cembalo Solos (Purcell): (a) Ground in C minor, (b) Toccata. 8.30, Talk: Dictators in the Past. 9.0, Concert of Swedish Folk Songs by the Orfeus Choir; Conductor, Sven Lizell; Soloist, Folke Jonsson (Baritone). 9.30, A Microphone Visit. 9.45, News. 10.0, Orchestral Concert: March (Hon); Guitar (Bizet): Selection from The Värmländers (Randel-Rudolf); Trümelei (Schumann); Serenade (Giuliano); Waltz (Waldteufel); By the Fountain (Ottoson); Cupid's Arrows (Freeman); Selection from The Gipsy Baron (Joh. Strauss). 11.0 (approx.), Close Down.

STRASBOURG

859 kc/s, 349.2 metres; 15 kW.—11.0 a.m., Orchestral Concert relayed from Lille, 1,213 kc/s, 247.3 metres. 12 Noon, Orchestral Concert. 1.5 to 2.0, Records of Light Music. 12.45 p.m., News. 1.0, Time; Exchange. 1.15, Orchestral Concert relayed from Paris (Ecole Supérieure). 2.0, Interval. 4.45, Literary Talk. 5.0, Programme from Lyons (la Doua), 463 metres. 6.0, Topical Talk in German. 6.15, French Elocution Lesson. 6.30, Programme from Paris (Radio Colonial), 19.68. 7.30, Time; News. 7.45, Records. 8.0, Press Review in German; Lottery Results; Announcements. 8.30, Les petites Brebis—Operetta in Two Acts (Varney). In the interval, News. 10.0, Orchestral Concert relayed from the Odéon Café; Conductor, Théodore; Amorettenzüge (Gungl); Overture, Eine Nacht in Venedig (Joh. Strauss); Schubert Potpourri; Potpourri, Echo de Russie (Léopold); Selection from White Horse Inn (Stolz-Benatzky). 11.0 (approx.), Close Down.

STUTTGART

MUHLLACKER, 574 kc/s, 522.6 metres; 100 kW.—5.35 a.m., Announcements. 5.45, Hymn; Time; Weather. 5.50, Gym. 6.15, Records. 6.40, Time; Announcements. 6.55, Records. 7.25, See Munich. 8.10, Weather. 8.15, Gym. 8.35, Water Level. 8.40, Interval. 9.0 to 9.15, Talk for Women. 10.0, News. 10.10, Violin and Pianoforte Recital by Theo Meyer and Eva Lorch: Sonata No. 1 in D, Op. 12 (Beethoven); Sonatina in G Minor (Schubert). 10.40, Soprano Song Recital by Maria Geiger, with Harpsichord Accompaniment. 11.0, Soldier Songs to the Lute, by Heinz Eschwege. 11.25, Announcements; Records. 11.55, Hints for Housewives. 7.40, Programme Announcements. 7.50, Announcements: Light Music. 8.0, Interval. 11.57, Time. 12 Noon, Fanfare from St. Mary's Church, Cracow. 12.3 p.m., Weather. 12.5, Press Review. 12.10, Concert of Light Music: Waltz Potpourri (Pewzner); Potpourri of Viennese Melodies (Kozzak); Paraphrase on Two Guitars (Katzer); Waltz (Pewzner); Parade of the Tin Soldiers (Jessel); Mazurka (Lewandowski). 12.45, Talk for Women. 1.0, News. 1.5, Records: Violin Concerto in E Flat (Mozart). 1.30, Interval. 3.30, Announcements. 3.35, Exchange. 3.45, Concert of Light Music by the Adamka-Grossman Ensemble: Lyric Suite (d'Albert); Air from Sigismund Angustus (Jotefko); Waltz from Najia (Delibes); Old Arietta (Brogli); Gondoliera (Moszkowski); In Seville (Ranzato). In the intervals, Tenor Solos by Adam Raczowski, relayed from Poznan, 868 kc/s, 345.6 metres. 4.45, Programme for Invalids relayed from Lwów, 795 kc/s, 377.4 metres. 5.15, Choral Concert from Poznan. 5.50, Book Review. 6.0, Talk for Young People. 6.10, Art Notes. 6.15, Trio Concert of Italian Music: Canto amoroso (Scarlati); Album Leaf (de Micheli); Sicilian Serenade (Becece); Leggenda d'amore (Becece); Pieces (Tosti): (a) Ivano, (b) Ideale, (c) Serenade. 6.45, Talk. 7.0, Records. 7.20, Talk: Results of the Gordon-Bennett Balloon Race. 7.30, Song Records. 7.45, Programme Announcements. 7.50, Sports Notes. 8.0, Hints for Holidays. 8.5, Talk on the following Transmission. 8.15, Concert of Polish Music by the Philharmonic Orchestra; Conductor, Fitelberg; Soloist, Hoffman (Pianoforte); Overture, Le conte (Moniuszko); Pianoforte Concerto in A Minor (Chopin); Symphony, From Spring to Spring (Noskovski). In the interval, News. 10.30, Recitations. 10.40, Announcements; Light Music. 11.0, Weather. 11.5, Dance Music from the Adria Café.

TOULOUSE

913 kc/s, 328.6 metres; 10 kW.—8.0 a.m., Dance Refrains. 8.30, News. 8.35, Concert. 12 Noon, Symphony Orchestra. 12.15 p.m., Songs. 12.30, News. 12.45, Request Programme. 1.0, News. 1.5, Soloist Concert. 1.15, Opera Arias. 1.30, Dance Music. 1.45, Chansonnets. 2.0, News. 6.0, News. 6.15, Orchestral Music. 6.30, Operetta Songs. 6.45, Orchestral Concert of Opera Music: Extracts from Madame Butterfly (Puccini), Carmen (Bizet) and Werther (Massenet). 7.0, Sound Film Music. 7.15, Orchestral Music. 7.30, News; Racing Results; Exchange. 7.45, Songs. 8.15, Reading. 8.30,

Medical Talk. 8.45, Opera Arias: Arias from Rigoletto (Verdi), Faust (Gounod), and Tales of Hoffmann (Offenbach). 9.0, Marine—Fantasy. 9.30, Concert. 10.0, Tyroese Music. 10.15, News. 10.30, Light Music. 11.0, Operetta Songs. 11.15, Music by a Viennese Orchestra. 11.30, Chansonnets. 11.50, Orchestral Music: Moment musical (Schubert); Suite orientale (Popy). 12 Midnight, News. 12.5 a.m. (Saturday), Au cavaeu de minuit—Fantasy. 12.15, Orchestral Music. 12.30, Close Down.

TRONDHEIM.—Relays Oslo. **TURIN**.—Relays Milan.

VALENCIA

850 kc/s, 352.9 metres; 1.5 kW.—2.0 a.m. to 3.0 a.m. (Saturday), Programme in English arranged by the International Broadcasting Company of London. 2.0 a.m., Organ Recital. 2.30, Military Band Concert. 3.0, L.B.C., Goodnight Melody and Close Down.

VATICAN CITY

15,120 kc/s, 19.84 metres; 10 kW (Morning), 5,970 kc/s, 50.26 metres (Evening).—11.0 to 11.15 a.m., Religious Information in German. 8.0 to 8.15 p.m., Religious Information in Italian.

VIENNA

592 kc/s, 506.8 metres; 120 kW. Relayed by Graz, 885 kc/s, 338.6 metres; Innsbruck, 519 kc/s, 578 metres; Klagenfurt, Linz and Salzburg, 1,294 kc/s, 231.8 metres.—9.0 a.m., News. 9.20, Market Prices. 9.30, Weather. 10.50, Water Level. 11.30, Records of Folk Music. 11.55, Weather. 12 Noon, Concert by the Vienna Symphony Orchestra; Conductor, Schönherr. In the interval at 1.0 p.m., Time; News. 2.0, Announcements. 3.30, Time; Announcements. 3.50, Readings for Women. 4.15, News. 4.20, Pianoforte Trio in G (Mozart) by the Schwarz Trio. 4.45, Operetta Records. 5.30, Talk. 5.55, Pianoforte Recital by Hedda Ballon: Prælude (Jos. Marx); Toccata (Heller); Extracts from the Triptych (Rinaldini); Schemzo (d'Albert); Rhapsody in C (Dohnany); Toccata (Casella). 6.25, Sports Review. 6.35, Tourist Report. 6.50, Time; News. 7.0, Local News. 7.20, Concert by the Vienna Symphony Orchestra; Conductor, Holzer; Soloist, Rita Georg (Soprano): Overture, The Queen's Kerchief (Joh. Strauss); Song from Roses from Florida (Fall); Song from Ball at the Savoy (Abraham); Intermezzo from The Count of Luxembourg (Lehár); Selection from Marietta (O. Straus); Songs from (a) The Duhray (Millock-Mackeben), (b) The Duchess of Chicago (Kálmán); Overture, Der Hofnarr (Müller); Song from Schön ist die Welt (Lehár); Millocker Potpourri (Morena); Polka, Leichtiges Blut (Joh. Strauss). 8.45, Variety Items. 8.55, Talk: Broadcasting and the Intellectual Life. 9.15, The Gothic Mass in D minor (Reidinger), by the Vienna Symphony Orchestra, and the Vienna State Opera Choir and Soloists; Conductor, Kabasta. 10.20, Popular Records. In the interval at 10.30, News. 11.20, Dance Music by the Totzauer Jazz Band; Soloist, Haintze (Song Refrains). 1.0 a.m. (Saturday), Close Down.

WARSAW

223 kc/s, 1,345 metres; 120 kW.—6.45 a.m., Hymn. 6.48, Records. 6.58, Gym. 7.8, Records. 7.15, News. 7.25, Records. 7.35, Hints for Housewives. 7.40, Programme Announcements. 7.50, Announcements: Light Music. 8.0, Interval. 11.57, Time. 12 Noon, Fanfare from St. Mary's Church, Cracow. 12.3 p.m., Weather. 12.5, Press Review. 12.10, Concert of Light Music: Waltz Potpourri (Pewzner); Potpourri of Viennese Melodies (Kozzak); Paraphrase on Two Guitars (Katzer); Waltz (Pewzner); Parade of the Tin Soldiers (Jessel); Mazurka (Lewandowski). 12.45, Talk for Women. 1.0, News. 1.5, Records: Violin Concerto in E Flat (Mozart). 1.30, Interval. 3.30, Announcements. 3.35, Exchange. 3.45, Concert of Light Music by the Adamka-Grossman Ensemble: Lyric Suite (d'Albert); Air from Sigismund Angustus (Jotefko); Waltz from Najia (Delibes); Old Arietta (Brogli); Gondoliera (Moszkowski); In Seville (Ranzato). In the intervals, Tenor Solos by Adam Raczowski, relayed from Poznan, 868 kc/s, 345.6 metres. 4.45, Programme for Invalids relayed from Lwów, 795 kc/s, 377.4 metres. 5.15, Choral Concert from Poznan. 5.50, Book Review. 6.0, Talk for Young People. 6.10, Art Notes. 6.15, Trio Concert of Italian Music: Canto amoroso (Scarlati); Album Leaf (de Micheli); Sicilian Serenade (Becece); Leggenda d'amore (Becece); Pieces (Tosti): (a) Ivano, (b) Ideale, (c) Serenade. 6.45, Talk. 7.0, Records. 7.20, Talk: Results of the Gordon-Bennett Balloon Race. 7.30, Song Records. 7.45, Programme Announcements. 7.50, Sports Notes. 8.0, Hints for Holidays. 8.5, Talk on the following Transmission. 8.15, Concert of Polish Music by the Philharmonic Orchestra; Conductor, Fitelberg; Soloist, Hoffman (Pianoforte); Overture, Le conte (Moniuszko); Pianoforte Concerto in A Minor (Chopin); Symphony, From Spring to Spring (Noskovski). In the interval, News. 10.30, Recitations. 10.40, Announcements; Light Music. 11.0, Weather. 11.5, Dance Music from the Adria Café.

ZURICH.—Relays Beromünster.

ATHLONE

565 kc/s, 531 metres; 60 kW. Relayed by Dublin, 1,348 kc/s, 222.6 metres; and Cork, 1,240 kc/s, 241.9 metres.—1.30 to 2.30 p.m., Time; Exchange; Weather; Records. 4.0 to 6.0, Concert by the Artane Band; Soloist, W. Lemass. 6.0, Records. 6.45, News. 7.0, Talk by M. Laverty. 7.15, Talk in Irish. 7.30, Time. 7.31, Music from the Masters—Concert by the Station Orchestra. 7.50, Talk: The Salzburg Festival. 8.20, Song Recital by S. Doherty (Soprano). 8.30, Comedy Sketch by Aoife Taaffe and Company. 9.0, Concert by the Station Orchestra. 9.30, Song Recital by M. O'C. Maguire (Bass-Baritone). 9.45, Pianoforte Recital by Carl Hardebeck. 10.0, Variety Programme. 10.30, Time; Weather; News. 10.40, Records. 11.0, Close Down.

BARCELONA

795 kc/s, 377.4 metres, 5 kW.—8.15 a.m., News; Records. 9.0, Chimes; Gym; Records. 9.20, News; Records. 10.0, Obituary. 12 Noon, Chimes; Weather. 1.0 p.m., Programme for Women. 1.45, Records. 2.0, Records. 2.30, Theatre Notes; Amusement Guide; Records. 3.0, News; Sextet Concert. Part I, Sound Film Music; Part II, Light Music, March (Ronald); Waltz from The Chocolate Soldier (O. Strauss); Spanish Serenade (Phaux); Song (Luna Moreno Torroba); Variation (Sancho-Marraco); Selection from La Gaita blanca (Jimenez-Vives). In the interval, Talk. 4.0, Programme for Hospitals. 4.30, Amateurs at the Microphone. 5.0, News. 7.0, Trio Concert, Overture, Zampa (Herold); Night on the Volga (Russo); Serenade (Doornack); Oriental Romance (Gaines); Intermezzo. Barberina (Lindsay); Idyl (Fevrier); Selection from Mignon (Thomas). In the interval at 7.30, News. 8.0, Request Records. 8.30, Exchange; Request Records. 9.0, Educational Programme. 9.10, Records. 9.30, Medical Talk in Catalan. 9.45, Press Review. 10.0, Chimes; Weather. 10.5, Social Notes. 10.10, Programme of Musical Comedies from Madrid (E.A.J.). 1.0 a.m., (Sunday), News. 2.0 till Close Down. Programme in English by the International Broadcasting Company of London. 2.0, Orchestral Music. 2.30, Variety Programme. 3.0, I.B.C. Goodnight Melody and Close Down.

BASEL.—Relays Beromünster.

BELGRADE

686 kc/s, 437.3 metres; 2.5 kW.—10.45 a.m., Programme Announcements. 10.50, Tides. 11.0, Records. 11.59, Chimes. 12.5 p.m., Concert by the Station Orchestra. 12.45, Exchange; Announcements. 1.0, Concert by the Station Orchestra. 1.30, News; Time. 4.0, Records. 4.30, Concert of Light Music by the 'Arancik Orchestra. 6.55, Time; Programme Announcements. 7.0, Concert of Slav Dances. 7.30, Announcements. 7.40, Concert (contd.). 8.0, Talk. 8.30, Mokrantsatz Concert by the Station Orchestra and Choir; Conductor, Jovanovic. In the interval at 10.0, Time; News. 10.30, Concert from the Ruski Car Restaurant. 11.0, Dance Records. 11.30, Close Down.

BERLIN

DEUTSCHLANDSENDER, 191 kc/s, 1,571 metres; 60 kW.—5.45 a.m., Weather. 5.50, News. 6.0, Gym. 6.15, Motto. 6.20, See Königsberg. In the interval at 7.0, News. 8.0, Interval. 8.45, Gym. for Women. 9.0, Interval. 9.40, Sports Notes. 10.0, News. 10.10, Rumpelstiltskin—Fairy Play after Grimm (Freund)—with Incidental Music. 10.40, Programme for Children. 11.15, Weather. 11.30, Reading (Schlepitzi). 11.45, Science Report. 11.55, Weather. 12 Noon, See Breslau. 12.55 p.m., Time. 1.0, Records of Light Music; Weather. 1.45, News. 2.0, Interval. 2.45, Greetings; Announcements. 3.0, Weather; Exchange. 3.15, Handwork Programme for Children. 3.40, Industrial Review. 4.0, See Frankfurt. 6.0, Sports Review. 6.20, Talk for Workers. 6.45, Programme Announcements. 6.55, A Poem; Weather. 7.0, Woods and Moors—Wind Instrument Concert on Records. 7.40, Topical Discussion. 8.0, Motto; News. 8.10, See Munich. 10.0, News. 10.30, Sports Talk; Caneing. 10.45, Weather. 11.0, Variety Programme, relayed from Munich. 12 Midnight, Close Down.

BERLIN

FUNKSTUNDE, 841 kc/s, 356.7 metres; 100 kW.—6.0 a.m., Hymn; Gym. 6.15, Weather; Meditation. 6.20, See Königsberg. In the interval at 7.0, News. 8.0 to 8.20, Gym. 10.0, News. 10.10, Exchange. 10.30, Records; Announcements. 11.0 to 11.30, Exchange. 12 Noon, Concert from Königsberg. In the interval at 12.30 p.m., Weather. 1.0, News. 1.15, Operetta Records: Overture and Song from Eine Nacht in Venedig (Joh. Strauss); Overture, Light Cavalry (Suppé); Selection from The Bird Fancier (Zeller); Overture and Song from Boccaccio (Suppé); Overture, Der Opernball (Heuberger). 2.0, News. 2.15, Dance Records. 3.0 to 3.20, Exchange. 3.35, Discussion: Mountains. 4.0, Concert by the Small Station Orchestra; Conductor, Steiner; Soloist, de Vogt (Songs to the Lute); Selection from Gri-Gri (Lincke); Tündelei (Sommer); Csardas, Magyar-bor (Muhr); In a Persian Market (Kettelbey); Waltz, Leuchtende Sterne (Robrecht); Songs to the Lute, Von Wald und Heide; Three Bavarian Dances (Pachernegg);

Wiener Puppen (Mühlenau); Poranek (Lindsay); Interlude, Discussion on Man's Aspirations and Technical Progress Heuzel-männchen (Hellmesberger); Kokoko-Liebes-lied (Meyer-Helmund); Songs to the Lute, Von Wald und Heide; Miniatures (Cui); Waltz, Ewig blauer Himmel (Kutsch). 6.0, Announcements. 6.5, Talk: Physical Training in France and Belgium. 6.20, Martin Plüdemann Song Recital. 6.50, Indian Summer—Sequence (Girgenson), with Incidental Music by Karl Knauer. 7.40, Echoes of the Day. 8.0, News. 8.15, Dance Music by the Hans Bund Band. 10.20, Weather; News; Sports Notes. 10.50, See Leipzig. 1.0 a.m. (Sunday), Close Down.

BERNE.—Relays Beromünster.

BEROMUNSTER

556 kc/s, 539.6 metres; 60 kW.—12 Noon, Records: Xylophone and Saxophone Music. 12.29 p.m., Time; Weather; News. 12.40, Operetta Music on Records. 1.25, Time; Weather; Exchange. 1.30, Parliamentary Notes. 1.45, Wireless Notes. 2.0, Book Review. 2.20, Concert by the Elite Accordion Orchestra; Conductor, Voegel. 2.40, Talk: Scientific Research. 3.0, Interval. 3.59, Time. 4.0, See Monte Ceneri. 6.0, Report from the Gempenstolle Gliding Camp. 6.30, Talk: Ludwig Richter. 7.0, Chimes. 7.15, Time; Weather; Market Prices. 7.20, Report: Tour of the Basle Municipal Theatre before the Curtain goes up. 8.0, Talk: Television. 8.30, Old 'Cello Music. 9.0, Weather; News. 9.10, Humorous Programme with Dance Music. 11.0 (approx.), Close Down.

BODEN.—Relays Stockholm. BODO.—Relays Oslo.

BRATISLAVA

1,004 kc/s, 298.8 metres; 13.5 kW.—6.0 to 7.15 a.m., See Prague. 9.45, Announcements. 9.50, See Prague. 10.10, News in Hungarian. 10.15, See Moravská-Ostrava. 11.0, Water Level. 11.5, See Prague. 12 Noon, Talk for Farmers. 12.10, p.m., Local News in Slovak. 12.15, Record. 12.20, See Prague. 12.30, See Moravská-Ostrava. 1.30, See Prague. 1.40, News in German and Hungarian. 1.50, See Prague. 2.0 to 2.5, Danube Shipping Company Report. 3.15 to 4.15, See Prague. 4.40, See Brno. 5.40, Topical Talk. 5.50, Record. 5.55, Talk for Workers. 6.10, Talk for Housewives. 6.15, Hungarian Transmission: Song Recital by Marie Németh. 6.55, See Prague. 7.10, See Moravská-Ostrava. 7.55, See Brno. 8.35, See Brno. 9.0, Vlachky—Folk Play with Songs (Brozik-Nizkovsky); Music by Kostál; The Station Orchestra; Conductor, Dyk. 10.0, See Prague. 10.15, News in Hungarian. 10.30, See Prague. 11.30, Close Down.

BREMEN.—Relays Hamburg.

BRESLAU

950 kc/s, 315.8 metres; 60 kW. Relayed by Gleiwitz, 1,231 kc/s, 243.7 metres.—5.0 a.m., Hymn; Motto; Records. 6.0, Time; Weather; Gym. 6.25 (from Gleiwitz), Band Concert; Conductor: Gielnik. In the interval from 7.0 to 7.15, Time; Weather; News. 10.40, Programme for Children. 11.30, Time, News; Weather; Water Level. 12 Noon, Concert by the Station Orchestra; Conductor: Topitz; March, Heil Europe (Blon); Overture, Semiramis (Rossini); Serenade, Les Millions d'Arlequin (Drigo); Waltz, Nord-seebilder (Joh. Strauss); Rosen-gavotte (Osterhold); Selection from Czar and Carpenter (Lortzing); Three Miniatures (Cui); Waltz, Die Hydriopatrien (Gungl); Hungarian Dances (Brahms); Overture, Paragrap III (Suppé); Overture, Venus auf Erden (Lincke); Annen-Polka (Joh. Strauss); Selection from Der Tenor der Herzogin (Künnecke); Gallop (Blon). In the interval from 1.30 to 1.45, Time; Weather; News. 2.20, Exchange. 2.25, Announcements; Records. 2.50, Programme for Farmers. 3.10, Talk: Unemployment in America. 3.30, Discussion: The Lutheran Bible. 4.0, Military Band Concert; Conductor: Kiefer; Landsknechte auf dem Marsch (Schmelzing); Festival Overture, Vivat Academia (Zimmer); Tanz der Glocken-blumen (Rathke); Scandinavian Wedding (Brase); Swabian Rhapsody No. 4 (Kaenip-fert); Waltz, Ein Frühlingssonntag (Rathke); March, Unter den Reichs-farben (Siede); March, Aufbruch der Nation (Sticheritz); Hessian Standard March (arranged Krause); Overture, The Thieving Magpie (Rossini); Selection from Der Freischütz (Weber); March (Böhlms); March (Schep-pang). 6.0, Talk: Reichenau Figures of Speech. 6.25, Topical Talk. 6.50, Programme Notes: Weather. 7.0, Chimes. 7.5, Eduard Reinacher reads his own Poems. 7.30, Programme Announcements with Records. 8.0, News. 8.10, See Königsberg. 10.0, Reading (Dr. Otto Weddingen). 10.20,

SATURDAY
SEPTEMBER THE TWENTY-NINTH

News. 10.45, Variety Programme from Freiburg; The Station Dance Band; Conductor: Illner; and Soloist. 1.0 a.m. (Sunday), Close Down.

BRNO

922 kc/s, 325.4 metres; 32 kW.—6.0 to 7.15 a.m., See Prague. 9.50, See Prague. 10.15, See Moravská-Ostrava. 11.0, See Prague. 12.30 p.m., See Moravská-Ostrava. 1.30, Talk for Tradesmen. 1.40, See Prague. 2.0 to 2.5, Market Prices. 3.15 to 4.15, See Prague. 4.40, Happy Week-End—Concert by the Station Orchestra; Conductor, Bakala; Czech Wakes (Moor); Sousedka (Chvala); Serenade (Suk); Potpourri (Maly); Czech Polka (Flegl); Waltz (Lucky); March (Nedbal). 5.40, Hints for Housewives. 5.45, German Transmission: Wagner Programme. 6.20, Literary Review. 6.35, Theatre Notes; Record. 6.45, Programme for Workers. 6.55, See Prague. 7.10, See Moravská-Ostrava. 7.55, See Prague. 8.35, Gym. Lesson accompanied by Kopecky (Accordion). 9.0, See Bratislava. 10.0, See Prague. 11.30 (approx.), Close Down.

BRUSSELS (No. 1)

620 kc/s, 483.9 metres; 15 kW.—11.55 a.m., Weather. 12 Noon, Orchestral Concert of Patriotic Songs. 1.0 p.m., News. 1.10, Records: Overture, 1812 (Tchaikovsky); Hymn to Liberty (Gosse); Extract from The Daughter of the Regiment (Donizetti); Li MÛysu Domine (Duyseux); Raspognans (Godard); Li Saint Amour (Van Damme); T'chanson dex verités (Lorienx); Extracts from La rosière de Saleny (Grétry) and Colinette à la Cour (Grétry); Crauignons liégeois (Prévoz). 2.0, Interval. 4.40, Announcements. 4.45, Talk. 5.0, Concert by the Radio Orchestra: Walloon March (Ernotte); Oriental Dance Suite (Hillier); Aphrodite (Jongen); Adagio pathétique for Violin and Orchestra (Marsick); Souvenirs (Jehin); Paysage (Rogister); Pastoral Suite (Ramsay); One-Step (Grillaert); Walloon Songs (Hillier). 6.0, Reading of Walloon Literature. 6.15, Programme for Young People. 6.45, Popular Walloon Music; Soloist, Durand (Tenor): Li s'cret de moïin (Batta); Two Songs (Van Damme); Minuet and Berceuse (Delporte); Chanson à Josette (Desprez); Printemps d'amour (Kalkman); Two Pieces (Grétry). 7.15, Talk: The Walloon Movement. 7.30, Science Talk; Wireless Notes. 8.0, Concert by the Symphony Orchestra: Soloists, Rachel Piette (Songs), Stoefs (Flute), Georges (Trombone), and Pouillard (Songs); Fantasia on a Walloon Theme (Ysaye); Aria from Richard Coeur de Lion (Grétry); Rhapsody on a Tournai Theme (Daneau); Nocturne for Flute and Orchestra (Marchot); Arioso for Trombone and Orchestra (Marchot); Duet from Masaniello (Auber); Extract from The Drum Major's Daughter (Offenbach); A Walloon Kondo (Jongen); Extracts from Jean Michel (Dupuis); Overture, Cour d'ognon (Dupuis); Duets (Marsick); Wal-loon Songs (Hillier); La Brabançonne (arr. Van Campenhout). In the interval at 9.0, Talk. 10.0, News. 10.10, Dance Records. 11.0, Dance Music from L'Antienne Bel-gique. 12 Midnight, Close Down.

BRUSSELS (No. 2)

932 kc/s, 321.9 metres; 15 kW.—Programme in Flemish.—11.57 a.m., Weather. 12 Noon, Records. 1.0 p.m., News. 1.10, Popular Orchestral Music; Soloist, Wig (Violin) and Steurs (Accordion): Une fête à Aranjuez (Demers-seman); Forest Murmurs (Razigade); Padilla Potpourri (Salabert); Polonaise No. 2 for Violin and Orchestra (Wieniawsky); Waltz Potpourri (Morena). 2.0, Interval. 4.40, Announcements. 4.45, Talk. 5.0, Programme for Children. 6.0, Records: Four German Dances (Mozart); Elegiac Melody (Grieg). 6.15, Talk. 6.30, Violin Recital by Amanda Webb. 7.0, Concerto No. 2 (Chopin) on Records. 7.30, Film Review. 7.55, News. 8.0, Orchestral Concert; Conductor, De Préter; Soloist, Henriette Clairy (Songs): Part I: Overture, Le roi d'Ys (Lalo); Procession nocturne (Rabaud); Songs: (a) Le drapeau (De Préter), (b) To Spring (Grieg); Autrefois (De Préter); Le chasseur mandit (Franck); Part II: Wagner: Prelude to Lohengrin; The Rhine Journey from Siegfried; Prelude and Death of Isolde from Tristan and Isolde; Overture, The Mastersingers (Wagner). In the interval, Humorous Programme. After the Concert, News. 11.0, See Brussels (No. 1). 12 Midnight, Close Down.

BUCHAREST

823 kc/s, 364.5 metres; 12 kW.—12 Noon, Water Level; Records. 12.45 p.m., Amusement Guide; Exchange; Records of Light Music. 1.15, Time; Weather; News. 1.40, Records of Light Music. 5.0, Concert of Popular Romanian Music by the Fanica Luca Orchestra. 6.0, Time; Weather; News. 6.15,

Concert by the Fanica Luca Orchestra. 7.0, Educational Programme. 7.15, Records. 7.45, Talk. 8.0, Song Recital by Mircea Lazar, accompanied by the Station Orchestra: Sicilienne (Mascagni); Flower Song from Carmen (Bizet); Aria from The Master-singers (Wagner); Aria from La Juive (Halévy). 8.20, Concert by the Station Orchestra: Ballet Music from Sylvia (Delibes); Ballet Music, Iris (Nottara). 9.0, Letterbox. 9.20, Concert by the Station Orchestra; Waltz from Schön ist die Welt (Lehár); Wienertanz No. 1 (Friedmann-Gärtner); Gavotte in D minor (Bach); Peasant Dance (Zanella); Dance (Mascagni); Russian Dance No. 1 (Bullfiance); Spanish Dance No. 6 (Granados); Rigaudon (Har-tog); Dance (Snoeck). 10.0, News.

BUDAPEST

546 kc/s, 549.5 metres; 120 kW.—6.45 a.m., Gym. 9.45, News. 10.0, Talk. 10.40, Talk. 12 Noon, Chimes from the University Church. 12.5 p.m., Military Band Concert. 1.30, Concert. 2.40, Hints for Housewives. 4.0, Handwork Lesson. 5.0, Orchestral Concert of Modern Light Music; Conductor, Fridl. 6.0, Talk. 6.30, Hungarian Folk Songs by Béla Csoka. 7.40, Gala Programme by the Philharmonic Society; Conductor, Pohnányi, The Hungarian National Anthem; Prologue. Talk: Hungarian Music; Festival Overture (Dolmányi); Dance (Kodály); Suite No. 1 (Bartok); Les Préludes (Liszt). 10.15, News. 10.40, Records.

CASSEL.—Relays Frankfurt.

COLOGNE

658 kc/s, 455.9 metres; 60 kW.—5.30 a.m., Hymn; Records. 6.5, Gym. 6.25, See Breslau. In the interval at 6.50, Time; News. 8.0, Time; Weather; Water Level. 8.5, Gym. for Women. 8.20 to 8.35, Practical Hints. 10.0, Time; News; Water Level. 10.10, Programme for Children. 10.30, Topical Readings. 11.30, Announcements. 12 Noon, Concert by the Station Quintet and the Frohe Sänger. In the interval at 12.45 p.m., Announcements; Greetings. 1.45, Announcements. 2.0, Records of Light Music. 2.45, Anecdotes. 3.30, Exchange. 3.45, Talk: The Uses of Gas. 4.0, Concert of Folk Songs; The Station Chamber Choir; Conductor, Breuer; The Station Children's Choir; Conductor, Hüsch; Soloists, Engels (Tenor), Remagen (Baritone), Ida Gille (Guitar), and Grape (Pianoforte). 5.0, Talk: Borken Museum. 5.15, Variety Programme by Young People. 5.45, Reading (Senge). 6.0, The German Calendar—October. 6.40, Topical Talk. 6.50, Exchange; Sports Notes. 7.0, Concert of Bellini Opera Music, with Commentary: The Station Orchestra and Station Chamber Choir; Conductor, Kühn; Soloists, Olga Schramm-Tschörner (Soprano), Engels (Tenor), and Rood (Baritone). 8.0, News. 8.15, Variety Programme by the Leo Eysoldt Orchestra; Irene de Noiret (Songs from Many Lands); Georg Neumüller (Bavarian Humourist), and Engels (Tenor). 10.0, Time; Weather; News. 10.20, Light Music and Dance Music by the Harvey and Wirtz von Lehn Bands, relayed from Gelsenkirchen-Horst. 1.0 a.m. (Sunday), Close Down.

COPENHAGEN.—Relays Kalundborg. CORK.—Relays Athlone. DANZIG.—Relays Königsberg. DRESDEN.—Relays Leipzig.

FECAMP

1,456 kc/s, 206 metres; 10 kW.—11.30 a.m. to 12 Noon, Programme in English arranged by the International Broadcasting Company of London: Happy Half Hour; Dance Music. 12 Noon, Programme in French. 4.30 to 6.0 p.m., Programme in English arranged by the I.B.C. (London). 4.30, Tunbridge Wells, Isle of Thanet, Dover and Folkestone Concert; Part I, Variety (Gramophone Records). 5.0, Part II, Dance Music. 5.30, Part III, Come to Spain. 6.0, Programme in French. 11.0 till Close Down. Programme in English arranged by the I.B.C. (London). 11.0, I.B.C. Member's Request Programme: A Raie da Costa Memorial Programme. 11.30, Concert arranged by the I.B.C. (Ireland), Ltd.: Music from the Opera. 12 Midnight, Dance Music by Ray Noble and his Orchestra (Gramophone Records). 12.15 a.m. (Sunday), Dance Music. 12.30, Concert for Roslin Listeners. 1.0 a.m., I.B.C. Goodnight Melody and Close Down.

FLENSBURG.—Relays Hamburg. FLOR-ENCE.—Relays Milan.

FRANKFURT

1,195 kc/s, 251 metres; 17 kW.—5.45 a.m., Hymn; Time; Weather. 5.50, Gym. 6.40, Time; News. 6.50, Weather. 6.55, See Stuttgart. 8.10, Water Level; Weather. 8.15 to 8.35, Gym. 10.0, News. 11.0, Concert. 11.30, Programme Notes; Market Prices; Weather. 11.45, Announcements. 12 Noon, Orchestral Concert; Conductor, Limpert; Overture, Le Maçon (Auber); Intermezzo from L'Amico Fritz (Mascagni); Selection from Adriana Lecouvreur (Cilea); Ballet Music from Sicilian Vespers (Verdi); Serenade from The Third Suite (de Michel); Selection from Dalibor (Smetana). 1.0 p.m., Time; News. 1.10, Wireless Notes. 1.20, See Stuttgart. 1.50, Time; News. 2.0, See Stuttgart. 2.30, Economics—Reports and Discussions. 2.50, Time; Market Prices. 3.0, Weather. 3.10, See Stuttgart. 3.30, Invitation to the Dance—Recital by Lilly Trautmann (Soprano) and Fritz Kullmann (Piano-

SEPT. 29th SATURDAY continued

(forte). 4.0, Variety Concert; The Station Orchestra; Conductor, Willy Nane; the Franz Renner Dance Band; Madlen Madsen (Soprano), and Emil Seidenspinner (Tenor). 6.0, Talk: Frontier Problems. 6.20, Weekly Review. 6.35, Surprise Programme. 6.50, Time; Weather. 7.0, Concert of Light Music by the Station Orchestra. 8.0, Time; News. 8.5, Local News. 8.10, See Munich. 10.0, Büdingen—Sequence (arr. Bassemann). 10.20, Time; News. 10.30 to 10.35, Local News. 10.45, Dance Music. 12 Midnight, See Stuttgart. 2.0 a.m. (Sunday), Close Down.

FREDRIKSSTAD.—Relays Oslo. **FREIBURG.**—Relays Stuttgart. **GENEVA.**—Relays Sottens. **GENOA.**—Relays Milan. **GLEIWITZ.**—Relays Breslau. **GÖTEBORG.**—Relays Stockholm. **GRAZ.**—Relays Vienna. **HAMAR.**—Relays Oslo.

HAMBURG

304 kc/s, 331.9 metres; 160 kW. Relayed by Bremen, Flensburg, and Hanover, 1,330 kc/s, 225.6 metres. 5.45 a.m., Time; Weather; Market Prices. 6.0, Gym. 6.15, Time; Weather. 6.20, See Königsberg. In the interval at 7.0, Time; Weather; News. 8.0, Talk for Housewives. 8.10, Announcements; Records. 10.50, News. 11.0, Scenes from the Life of Theodor Storm (Albert Petersen). 11.30, See Königsberg. In the interval at 12 Noon, Talk for Housewives; Time; Weather; Shipping. 1.0 p.m., Exchange. 1.15, Weather. 1.20 (from Stettin), Musical Programme. 2.15, News. 2.30, Everything has Rhythm—Gramophone Concert; Spanish March, Lolita (Santuzini); Waltz, Rief brummt der Bass (Blume and Ebert); Foxtrot, Lollipops (Reser); Folk Songs for Choir, Wenn die Soldaten; Violin Solo: Serenade (d'Ambrosio); Intermezzo, Vielliechen (Siede); Marching Song, Lola (Ulmland); Foxtrot, Pacific Express (Mecchichino-Lazzarini). 3.0, Wireless Announcements. 3.15, Exchange. 3.40, Shipping and Aviation Notes. 4.0 (from Kiel), German Week at Kiel—Band Concert; Conductor, Hori; March, Germania (Heil); Festival Overture (Leutner); Selection from The Gipsy Baron (Joh. Strauss); Intermezzo, Goldregen (Kockert); Waltz, Ein Frühlingssonntag (Rathke); March, Frei weg (Latam); Potpourri, Deutscher Sang (Hannemann); Parade im Märchenwald (Noack); Lagunen-Walzer (Joh. Strauss); Intermezzo (Lindsay); Archduke Albrecht, March (Komzak); Titania March (Schwittmann). 5.30, Wilfred Wood reads from his own works. 6.0, Records; Overture, Maritana (Wallace); Waltz from Frau Luna (Lincke); Song from Die Fledermaus (Strauss); Selection from The Land of Smiles (Lehar); Komm mit mir, Schatz (Lührs); Pizzicato Polka (Strauss); Grau in Grau (Kirchstein). 6.35, Programme for Soldiers. 6.55, Weather. 7.0 (from Hanover), Pianoforte Recital by Willy Craney (Pianoforte); Impromptu in B Minor (Schubert); Jardins sous la pluie (Debussy); Ballad in D Minor (Marx); Tarantella, Venezia e Napoli (Liszt). 7.30, Reading. 8.0, News. 8.10, From St. Paul to Haiti—Programme of Dance Music by the Station Dance Band and Soloists; Conductor, Bolt. In the interval at 10.0, News. 12 Midnight, Dance Music from Leipzig. 1.0 a.m. (Sunday), Close Down.

HANOVER.—Relays Hamburg.

HILVERSUM

100 kc/s, 1,875 metres; 7 kW. (until 3.40 p.m.). Transmitted on Kootwijk, 50 kW., from 3.40 p.m.—7.40 to 9.40 a.m., Programme of the Workers' Radio Society (V.A.R.A.): Records. 9.40 to 9.55, Religious Programme of the Liberal Protestant Radio Society (V.P.R.O.). 9.55 till Close Down, V.A.R.A. Programme. 9.55, Concert. 11.40, Orchestral Concert of Light Music; Conductor, Wius. 1.25 p.m., Interval. 1.40, Talk. 1.56, Records. 2.10, Organ Recital of Light Music by Jong. 2.40, Film Review. 2.55, Song Recital by Mia Dorel with Pianoforte and Accordion Accompaniment. 3.25, Interval. 3.40, Concert of Light Music by the V.A.R.A. Small Ensemble; Conductor, Bakels. 4.25, Talk. 4.40, Concert (contd.). 5.20, Literary Talk. 5.40, Records. 6.10, Song Recital with Talk. 6.40, Folk Lore. 7.0, Concert by the V.A.R.A. Children's Choir. 7.40, S.O.S. Announcements. 7.43, Records. 8.0, Talk. 8.10, Dance Music. 8.40, Concert by the Preciosa Male Voice Octet; Du Hirte Israëls (Bortnanski); Litanei (Schubert); Heilig, heilig (Schubert); Heerenhuis (Boers). 8.55, Announcements. 9.10, Octet Concert (contd.). 9.20, Concert of Light Music by the V.A.R.A. Orchestra; March (Sontag); Paysages d'Automne (Waldfuefel); Slav Rhapsody No. 1 (Friedemann). 9.40, News. 9.55, Concert (contd.): Selection from Les Dragons de Villars (Maillart); Suite from Carmen (Bizet); Humoresque (Dvorák); Slav Dances (Dvorák). 10.25, Records. 10.40, Concert (contd.): Das Dorfgelächeln (Gerstenberg); Gipsy Idyll (Ferraris); Waltz, Wo die Zitronen blühen (Strauss); Extase (Ganne); Selection from White Horse Inn (Stolz-Benatzky). 11.10, Records. 11.40, Close Down.

HORBY.—Relays Stockholm.

HUIZEN

995 kc/s, 301.5 metres; 7 kW. (until 6.40 p.m.). 20 kW. from 6.40 p.m. Programme of the Catholic Radio Society (K.R.O.).

7.40 a.m., Records. 8.55, Interval. 9.40, Records. 10.10, Concert. 10.40, Records. 11.10, Religious Address. 11.40, Police Messages. 11.55, Records. 12.40 p.m., Light Music by the K.R.O. Boys; Conductor, Lustenhower. 1.25, Interval. 1.40, Programme for Young People. 2.10, Records. 2.40, Programme for Children. 3.40, Choral and Orchestral Concert with Records, relayed from Gilze-Rijon. 4.50, Talk on Esperanto. 5.0, Records. 6.0, Press Review. 6.25, Records. 6.40, Police Notes. 6.55, Talk. 7.15, Records. 7.26, Concert by the K.R.O. Orchestra; Conductor, Van 't Woud; Overture, Chal Romano (Ketybej); Il Bacio (Arditi); Potpourri (Hrubý); Slav Rhapsody No. 1 (Friedemann). 8.15, News. 8.15, Talk. 8.25, Concert (contd.): Freiheitsjubel (Blankenburg); Overture, Die schöne Galathee (Suppé); Two Pieces (MacDowell): (a) To a Wild Rose, (b) To a Water Lily; Gnomes March (Ketybej); Love's Dream after the Ball (Czibulka); Nocturne in E Flat, No. 2, Op. 9 (Chopin); Bank Holiday (Ketybej); Toreador and Andalous (Rubinstein); March (Piercy). 9.10, Talk. 9.25, Recital by Wim Sommeveld (Pianoforte) and Fons Goossens (Songs to the Guitar). 9.40, Light Music by the K.R.O. Boys; Conductor, Lustenhower. 10.10, News. 10.15, Songs. 10.25, Light Music by the K.R.O. Boys. 11.10, Records. 11.40 (approx.). Close Down.

INNSBRUCK.—Relays Vienna.

KALUNDBORG

238 kc/s, 1,261 metres; 75 kW. Relayed by Copenhagen, 1,176 kc/s, 255.1 metres, and Skamlebaek, 49.5 metres.—7.0 a.m., Gym. 8.30, Divine Service from Copenhagen Cathedral. 11.0, Weather. 11.10, Fish Prices. 11.5, German Broadcast for Schools. 12 Noon, Time; Chimes. 12.2 p.m., Concert by the Harald Andersen's String Ensemble, relayed from the Bellevue Strandhotel. 2.0, Reading (Kainbau). 2.30, Popular Records. 3.0, Programme for Children. 3.30, Concert by the Radio Orchestra; Conductor, Reesen; Soloist, Edga Gaspari (Pianoforte); Overture, Norina (Bellini); Ballet Music from Faust (Gounod); Träume (Wagner-Svendsen); Extract from the Lyric Suite (Grieg); Valse triste (Sibelius); Finlandia (Sibelius); Pianoforte Solos: (a) Prelude, Fugue and Variations (Franck), (b) Sicilienne (Bach-Galston), (c) Gavotte and Minuet (Bach); Three Dances from The Bartered Bride (Smetana); Selection from Javotte (Saint-Saëns); Frühlingsglaube (Schubert-Reesen); Balscene (Mayseder-Helmsberger); Extract from Scenes napolitaines (Massenet). 5.30, Exchange; Fish Market Prices. 5.42, A Poem. 5.45, English Talk: The Week-end and Sport in England. 6.15, French Lesson. 6.45, Weather. 7.0, News. 7.15, Time. 7.30, Political Review. 8.0, Time. 8.1, Talk: Holberg Characters—Erasmus Montanus. 8.45, Sonata in G for Violin and Harpsichord (Emborg). 9.0, Dance Music by Louis Preil's Instrumental Ensemble. 9.25, Contemporary Danish Song Recital by Else Ammentorp. 9.40, Dance Music (contd.). 10.10, News. 10.25, Dance Music by Louis Preil's Dance Band. 11.15, Modern Danish Lyrics by Lulu Ziegler. 11.30, Dance Music (contd.). 12.30 a.m. (Sunday), Close Down.

KIEL.—Relays Hamburg. **KLAGENFURT.**—Relays Vienna.

KONIGSBERG

1,031 kc/s, 291 metres; 60 kW. Relayed by Danzig, 1,303 kc/s, 230.2 metres.—5.0 a.m., Records. 5.50, Weather. 6.0, Gym. 6.20, Band Concert; Conductor, Kosenmund. In the interval at 7.0, News. 8.0, Service. 8.30 to 9.0, Gym. for Women. 10.40, News. 10.55, Weather. 11.5, Agricultural Talk. 11.30, Band Concert; Overture, King Midas (Eilenberg); Song, An der Weser (Pressel); Mimosa Waltz from The Golska (Jones); The Mill in the Black Forest (Eilenberg); Student Song Potpourri (Schmützer); Liebesserenade (Noack); Potpourri of Johann Strauss Waltzes (Ed. Strauss); Schön ist die Jugend (Rhode); March (Somtag). In the interval at 12 Noon, Weather. 1.0 p.m., Time; Weather. 1.5, Records. In the interval at 1.20, News; Programme Notes. 2.0, News. 2.30, Announcements; Records. 3.0, Market Prices. 3.10, Book Review. 3.20, Talk for Women. 3.30, Schwätzchen hinterm Kürris—Play for Young People (Biemann). 4.0 (from Danzig), Concert by the Danzig Theatre Orchestra; Conductor, Kallipko; Overture, The Water Carrier (Cherabini); Selection from Tieftand (d'Albert); From the New World (Dvorák); Greek Dance Suite, Erinaka (Schragder); Waltz, Nordseebilder (Joh. Strauss); Ballet Fantasia (Paepke); Narcissus (Nevin); Slow Waltz (Schütt); Ballet Music from Il Cossallo di Szigetiz (Smareglia); Overture, Waldmeister (Joh. Strauss). In the interval at 5.0, Road Report. 5.45, Book Review. 6.15, Market Prices. 6.25, Organ Recital by Schütz; Passacaglia in D Minor (Buxtehude); Sonata on the Ninety-Fourth Psalm

(Reybke). 7.0, Topical Talk. 7.25, Recital by Henry Wolf (Soprano) and Hermann Schenk and Paul Schmidtke (Trombone). 8.0, News. 8.10, Goodbye to Summer—Humorous Sequence (Lange) with Music by Henschke; The Station Orchestra, Dance Band and Soloists. 10.0, News. 10.30, Records. 10.50, See Leipzig. 12.30 a.m. (Sunday), Close Down.

KOSICE.—Relays Prague. **LAUSANNE.**—Relays Sottens.

LEIPZIG

785 kc/s, 382.2 metres; 120 kW. Relayed by Dresden, 1,285 kc/s, 233.5 metres.—5.50 a.m., Notes for Farmers. 6.0, Gym. 6.25, See Breslau. In the interval at 7.0, News. 8.0, Gym. 8.20 to 9.0, Records. 9.40, Economic Report. 9.45, Programme Notes. 9.55, Weather; Water Level. 11.0, Announcements; Records. 11.30, News; Time. 11.40, Weather. 11.45, Programme for Farmers. 12 Noon, Concert by the Leipzig Symphony Orchestra; Conductor, Blumer; Overture, Czar and Carpenter (Lortzing); German Dances (Roger); Idyll, Biene Maja (Schroeder); Carnaval à Paris (Svendsen); Waltz, Wiener Fresken (Jos. Strauss); Little Suite (Niemann); Overture, Ilka (Doppler). 1.0 p.m., News; Time. 1.10, Records of Old Songs. In the interval at 2.0, News; Exchange; Weather. 2.15, Records. 2.30, Fairy Tales for Children. 3.10, Weekly Review. 3.25, Talk: Books for Girls. 3.45, Economic Notes; Weather; Time. 4.0, See Frankfurt. 5.30 (from Dresden), Zither Duets by Adolf and Anna Arnold. 6.0, A Modern Dictionary. 6.15, Report from the Saal and Unstrut Wine Growing Districts. 7.0, Recital of Lönis Songs to the Lute by Oskar Besenfelder; Auf der Lüneburger Heide; Wilde Rosen; Der Tauber; Im Walde; Aus und vorbei; Das beste Wildbrät; Schifferlied; Das Buchenblatt; Die goldene Wiege; Hunsentied. 7.30, Talk: The German Peasant's Home. 7.55, Announcements. 8.0, News. 8.15, Concert of Dance Suites; The Leipzig Symphony Orchestra and the EmDe Orchestra; Conductor, Weber; Soloists, Ria Rosal (Soprano) and Rio Gebhardt (Pianoforte); Tanz in der Dorfschenke (Liszt); Recitative and Polonaise from Mignon (Thomas); Ballet Music, Ritter Pasman (Joh. Strauss); Concerto in E flat for Pianoforte and Orchestra (Gebhardt); Ballet Scenes (Glazunov); The Blue Danube—Waltz for Soprano and Orchestra (Joh. Strauss); Symphonic Dance Suite (Künneke). 10.20, News; Sports Notes. 10.50, Dance Music by the EmDe Orchestra. 1.0 a.m. (Sunday), Close Down.

LINZ.—Relays Vienna.

LUXEMBOURG

230 kc/s, 1,304 metres; 150 kW.—7.45 a.m., Records. 8.0, News in French; Record; News in German; Record. 12 Noon, Concert by the Station Orchestra; Conductor, Pensis; Overture, Raymond (Thomas); Potpourri (Adam); Meditation from Thais (Massenet); Les Elfes s'amuse (Gaches); Andalous (De Taeye). 12.30 p.m., News in French and German. 12.40, Concert (contd.). Suite variée (Pierne); Piece (Wood); Aubade (Caludi); Sérénade d'Arlequin (Van Dam); Léhar Potpourri (Hrubý). 1.15, Records. 3.45, Exchange. 6.30, Concert of Light Music and Dance Music. 7.30, Racing Results; Exchange. 7.35, till Close Down. French Evening. Concert of French Music by the Station Orchestra; Conductor, Pensis; Overture, Le Roi Pa dit (Delibes); Scènes écossaises for Oboe and Orchestra (Godard); Pavane pour une Infante défunte (Ravel). 8.0, News in French and German. 8.30, Humorous Programme. 9.0, Social and Economic Notes. 9.5, Concert by the Station Orchestra; Conductor, Pensis; Soloist, Victor Jaans (Baritone); Prelude in G minor (Hardmann); Aria from La Bohème (Puccini); Extracts from Lakmé (Delibes); Méditation (Glazounov); The Two Grenadiers (Schumann); Rhapsody No. 6 (Liszt); Aria from Le Châlet (Adam). 10.0, Musical Programme. 10.50, Dance Records.

MADRID

EAJ7, 1,095 kc/s, 274 metres; 7 kW.—9.0 a.m., News. 10.0, Exchange; Announcements. 10.30, Interval. 2.0 p.m., Chimes; Weather; Variety Music; Talk. 2.30, Concert by the Station Sextet; Pasodoble (San José); Seguidillas del velatorio (Barrios); El zacateque (Barrios); Selection from Marenma (Allegro). 3.0, Amusement Game; Exchange; Variety Music. 3.30, Concert by the Station Sextet; Petite Suite (Busser); Marche des petits soldats de plomb (Pierne). 4.0, News; Variety Music. 4.30, The Station Sextet; Symphonic Caprice (Lehmberg); Potpourri (Nichols). 4.50, Film Notes; News. 5.0, Interval. 6.0, Chimes; Light Music. 7.0, Announcements. 7.10 (approx.), Orchestral Concert; Overture, Hansel and Gretel (Humperdinck); Marche militaire (Schubert); Selection from Coppélia (Delibes); Intermezzo, La leyenda del beso (Soutullo and Vert); Romance

(Tchaikovsky); Pavane pour une Infante défunte (Ravel). 7.30, Exchange; Duets. 8.0, News. 8.10, Guitar Solos. 8.25, Concert. Part I: Orchestral Music; Part II: Flamenco Songs; Part III: Pianoforte Recital. 9.40, Sports Notes. 10.0, Chimes. 10.10, A Musical Comedy; The Station Orchestra and Soloists; Conductor, Cantos. In the interval at 11.0, News. 12.45 a.m. (Sunday), News. 1.0, Chimes; Close Down.

MALMO.—Relays Stockholm.

MILAN

814 kc/s, 368.6 metres; 50 kW. Relayed by Turin, 1,140 kc/s, 263.2 metres; Genoa, 986 kc/s, 304.3 metres; and Florence, 610 kc/s, 491.8 metres.—7.30 a.m., Gym. 7.45 to 8.0, Time; News. 11.30, Records. 12.45 p.m., News. 1.0, Time; Announcements. 1.5 to 2.15, Concert by the Malatesta Chamber Orchestra. In the interval from 1.50 to 1.45, Records. 4.35, News. 4.45, Programme for Children. 5.0, Talk for Women. 5.10, Dance Music. 5.55, Weather. 6.0 to 6.10, Wheat Market Report; Lottery Results. 7.0, Tourist and Dopolavoro Notes. 7.15, News in Foreign Languages. 8.0, Time; News; Records. 8.30, Talk: Sport. 8.45, L'amore dei tre re—Opera in Three Acts (Montezzi). Talk and Book Review in the intervals. News after the Programme.

MONTE CENERI

1,167 kc/s, 257.1 metres; 15 kW.—12 Noon, Announcements; News; Concert by the Station Orchestra; March (Blankenburg); Waltz, Die Schönbirner (Lauer); Overture (Rossi); Russian Romance (Friml); Selection from Martha (Flotow); Suite (Anbert). In the interval at 12.29 p.m., Time; Weather. 12.55, Announcements. 1.5, Records. 1.30, Report for Motorists. 1.40, Records. 1.50, Talk for Housewives. 2.0, Interval. 3.59, Time. 4.0, Recital of Neapolitan Songs. 4.30, Clarinet Solos by Rubino; March (Carosio); Spanish Waltz (Cerafo); Argentine Tango (Carosio); Mazurka (Petillo); Waltz from Mirella (Gounod); Invitation to the Polka (Rubino). 5.00, Concert by the Vidor von Jekim Quartet from a Café. 5.30, Old Dance Music; Minuet (Galimberti); Gavotte (Graziani); Quadrille (Richardson); Schottisch (Vendral); Polka (Carosio); Mazurka (Piacenza); Waltz (Arditi). 6.0, Interval. 7.44, Announcements; Time. 8.0, Concert of Popular Music. 8.45, Programme Announcements. 9.0, Vendemmia—Musical Play in Three Acts (Gragnani) Orchestra, Choir and Soloists. Conductor, Filippello. In the interval: Talk.

MORAVSKA-OSTRAVA

1,158 kc/s, 259.1 metres; 11.2 kW.—6.0 to 7.15 a.m., See Prague. 9.50, See Prague. 10.15, Brass Band Concert. Conductor, Malik. 11.0, See Prague. 12 Noon, Talk for Farmers. 12.10 p.m., See Prague. 12.30, Concert by the Station Orchestra. Conductor, Divis. 1.30 to 2.0, See Prague. 3.15 to 4.15, See Prague. 4.40, See Brno. 5.40, Talk: The Idea of a United States of Europe. 5.50, Topical Talk. 6.0, News. 6.5, Talk on Bull-fighting. 6.20, Talk for Workers. 6.30, Schrammel Concert. 6.55, See Prague. 7.10, Revue (arr. Zeman-Musil). The Station Orchestra and Soloists. Conductor, Musil. 7.55, See Prague. 8.35, See Brno. 9.0, See Bratislava. 10.0, See Prague. 11.30 (approx.), Close Down.

MOSCOW (No. 1)

174 kc/s, 1,724 metres; 500 kW.—5.0 a.m., News. 5.15, Fanfare. 5.45, Gym. 6.15, Musical Programme. 8.15, Programme for Children. 9.0, Musical Programme. 9.58, Time. 10.0, News. 10.15, Concert for Collectivist Farmers. 3.0 p.m., Programme Announcements. 3.15, Programme for Children. 3.58, Time. 4.0, News. 4.15, Book Review. 9.0, Programme in German; Talk on the Harvest; Sports Notes. 10.5, Programme in French; Review of the Week; Letter Box; Sports Notes. 11.5, Review of the Week and Letter Box in Spanish.

MOTALA.—Relays Stockholm. **MUHLACKER.**—See Stuttgart.

MUNICH

740 kc/s, 405.4 metres; 100 kW. Relayed by Augsburg and Nürnberg, 1,267 kc/s, 236.8 metres.—6.30 a.m., Gym. 6.45, Motto; Records. 7.15, Time; Weather; News. 7.25, Programme from Stuttgart. 10.40, Notes for Farmers. 10.50, Market Report. 11.0, Talk. 11.20, Time; Weather; News. 11.30, Records; Announcements. 12 Noon, Records. 1.15 p.m., Time; Weather; News. 1.25, Concerto in G for Pianoforte and Orchestra (Beethoven), by the Station Orchestra, conducted by Winter; Soloist, Frieda Stahl (Pianoforte). 2.0, News; Sports Notes; Programme Announcements. 2.20 (from Nürnberg), Musical Programme for Young People. 2.45 (from Nürnberg), Chess Lesson. 3.15, Reading. 3.35, Weather; Market Prices. 3.50, Labour Exchange. 4.0, See Frankfurt. 5.30, Talk; Harvest Customs. 5.50, Pieces for String Quartet (Kirchner). 6.10, Reading for Girls. 6.30, Talk: By Car through South-West Africa. 6.50, Wireless Notes. 7.0, Dance Music by the Station Dance Band; Conductor, Antich. 8.0, News. 8.10, The October Festival—Variety Programme. 10.0, News. 10.20, Programme to be announced. 10.40, Variety Programme (contd.). 12 Midnight, Close Down.

NAPLES.—Relays Rome. **NOTODDEN.**—Relays Oslo.

OSLO

254 kc/s, 1,154 metres; 60 kW. Relayed by Hamar, 519 kc/s, 578 metres; and Jeløy, 6,990 kc/s, 42.92 metres.—11.15 a.m., Service. 11.50, Exchange. 12.55 p.m., Nauen Time Signal. 1.0 to 2.0, Records. In the Interval at 1.15, Weather; Talk for Farmers; and at 1.45, Exchange. 5.0, Orchestral Concert. 6.0, Programme for Children. 6.45, Talk: Economics. 7.0, Announcements. 7.15, Weather; News. 7.30, Time. 7.31, Concert of Norwegian Music. 8.0, Revue relayed from the Chat Noir. In the Interval at 9.20, Topical Talk. 9.40, Weather; and at 9.45, News. 11.0, Dance Records. 12 Midnight, Close Down.

OSTERSUND.—Relays Stockholm

PARIS

ECOLE SUPERIEURE, 695 kc/s, 431.7 metres; 7 kW.—8.0 to 8.30 a.m., News. 10.30, Concert from Marseille, 749 kc/s, 400.6 metres. 12 Noon, Tourist Talk. 12.15 p.m., Quintet Concert. In the Interval at 1.0, News. 1.30, Programme by René Gerly. 2.0, Records. 2.30, Vocal Programme. 6.0, Literary and Science Talk. 6.30, News. 7.45, Legal Talk. 7.53, Talk: Animal Protection. 8.0, Records: D'une prison (Hahn); Arias from Maon (Massenet); Sigurd (Reyer); Le Pré aux Clercs (Hérold); Les Noces de Jeannette (Massé); Chansons de Miarka (Georges). 8.30, Symphony Concert by the National Orchestra; Conductor, Desormière; Soloist, Mlle. Rolland (Songs); Orchestral Suite, Jephthé (Montclair); Ballet Suite (Glück); Songs: Aria from Zémir et Azor (Grétry); Le jeune pâtre breton (Berlioz); Symphonic Poem, Phédon (Saint-Saëns); Two Songs: Valse nobles et sentimentales (Ravel). After the Concert, News. 10.0, Dance Music.

PARIS

POSTE PARISIEN, 959 kc/s, 312.8 metres; 100 kW.—7.10 a.m., Fanfare; Records. In the intervals, News; Cookery Hints. 12 Noon, Exchange. 12.5 p.m., Thomas Records: Extracts from Hamlet and Mignon. 12.25, News. 12.35, New Records. 1.5, Exchange. 1.15, Concert by the Station Orchestra: Overture, L'oiseleur (Baukner); Two Romanian Dances (Bola); Selection from La Mascotte (Andran); Oriental Dance (Glazunov); Extract from Jeux d'enfants (Bizet); Waltz, Bleuets et coquelicots (Waldeufel). 2.0, Interval. 3.45, Exchange. 6.45, Exchange. 6.49, Extract from L'Apprenti sorcier (Dukas) on Records. 7.2, Topical Talk. 7.10, News. 7.30, Songs of the Sea (on Records). 8.0, Interval. 8.10, Weekly Review. 8.20, Concert. 8.50, Interval. 9.0, Dance Music by the Station Jazz Band, A Vocal Trio and Carol King (Songs); Conductor, Alain Romans. 10.20, News; Exchange. 10.30 till Close Down, Programme in English arranged by the International Broadcasting Company of London. 10.30, An Evening on the Pier. 11.0, I.B.C. Goodnight Melody; Close Down.

PARIS

RADIO PARIS, 182 kc/s, 1,648 metres; 75 kW.—6.45 a.m., Gym. 7.0, Records. 7.15, News. 7.45, Gym. 8.0, Records of Light Music. 12 Noon, Symphony Concert; Conductor, André: Marche des louis d'or (Fauchey); Waltz (Zichner); Overture, Le pré aux clercs (Hérold); Songs, Forest Murmurs (Czibulka); Fantasia; Songs; Minuet (Valensi-Daube); Selection from The Prophet (Meyerbeer); Duets; Gavotte (Bernard); Selection from Giroflé-Girofla (Lecocq); Songs; Waltz, Venezia (Désormes); Selection from Fortunio (Messager); Le coillon des nymphes (Février); The Cooks (Gabriel-Marie); The Teddy Bears' Picnic (Bratton). 3.0, Programme for Children. 6.20, Announcements; Practical Beekeeping; Exchange; Racing Results. 6.35, Two Talks. 7.0, Science Talk. 7.15, Press Review. 7.30, Topical Talk. 8.0, Flossie—Operetta (Szulc); Conductor, Labis. In the intervals at 8.20, News; and at 9.15, News; Review by Bonnaud. 10.30, Dance Music by the Golden Band.

PITTSBURGH

KDKA, 980 kc/s, 306 metres; 50 kW. Relayed by W8XK on 48.86 metres; and 25.27 metres.—3.0 p.m., Edward MacFugh. 3.15, KDKA Home Forum. 3.30, Singing Strings. 3.45, News; Originalities. 4.0, Bobby and Sue—Helen Irwin. 4.15, KDKA Kiddies' Klub. 5.0, Fields and Hall. 5.15, Genia Fonarova. 5.30, Vic and Sade. 5.45, Paul Pendarvis and his Orchestra. 6.0, Words and Music. 6.15, Songfollies. 6.30, Farm and Home Hour. 7.30, Royal Hawaiian Orchestra. 8.0, Tommy Tucker's Orchestra. 8.30, Saturday's Songsters. 9.0, Don Carlos and Orchestra. 9.15, Platt and Nerman. 9.30, Chicago Symphony Orchestra. 10.30, A Recreo—Bill and Alex. 10.45, Orphan Annie. 11.0, Time; Temperature; Weather. 11.14, Goodrich Baseball Résumé. 11.30, Twenty Fingers Harmony. 11.45, John Herrick (Baritone). 12 Midnight, Programme to be announced. 12.15 a.m. (Sunday), Al Williams. 12.30, Hotel William Penn Orchestra. 1.0 to 6.0 a.m., Popular Programme.

PORSGRUND.—Relays Oslo.

PRAGUE

638 kc/s, 470.2 metres; 120 kW.—6.0 a.m., Gym.; Music; News; Weather. 7.15, Interval. 9.50, News. 10.5, News in German.

SEPT. 29th SATURDAY continued

10.10, Record. 10.15, See Moravská-Ostrava. 11.0, Record. 11.5, Recital by Mužik's Quartet: Overture, The Devil and Kate (Dvorak); Caucasian Sketches (Ippolitov-Ivanov); Piece; Intermezzo (Stelzig); Tango (Benes). 11.55, Notes for Farmers; Exchange; Weather. 12 Noon, Time; Notes for Farmers; Hints. 12.10 p.m., Records. 12.20, News; Weather. 12.30, See Moravská-Ostrava. 1.30, Talk: Industry. 1.40, Records. 1.50, Exchange. 1.55, Exchange and Weather in German. 2.0, Interval. 3.15, Dance Music by Harry Osten and his Jazz Orchestra; 4.15, Interval. 4.40, See Brno. 5.30, Announcements. 5.45, Notes for Farmers; Market Prices. 5.55, Record. 6.0, Talk for Workers. 6.10, Record. 6.15, German Transmission: Recital by Members of the German Theatre in Prague; Four Songs (R. Strauss); Aria from Czar and Carpenter (Lortzing); Operetta Songs. 6.50, Sports Notes; News. 7.0, Time; News; Weather. 7.10, See Moravská-Ostrava. 7.55, Talk. 8.10, Eight Songs from Op. 39 (Novák) by Martha Krasova (Contralto). 8.45, See Brno. 9.0, See Bratislava. 10.0, Time; News; Sports Notes. 10.15, Records. 10.30, Wind Band Concert. 11.30, Close Down.

RJUKAN.—Relays Oslo.

ROME

Call 190, 713 kc/s, 420.8 metres; 50 kW. Relayed by Naples, 1,104 kc/s, 271.7 metres; Milan No. 2, 1,348 kc/s, 222.6 metres; Turin No. 2, 1,357 kc/s, 221.1 metres; and 2R0, 11,810 kc/s, 25.4 metres.—7.30 a.m., Gym. 7.45 to 8.0, Time; News. 12.30 p.m., Records. 1.5 to 2.15, Light Music: Melody (Kochmann); Song, Stornello al sole; Selection from The Dollar Princess (Fall); Life in Japan (Higgs); Caucasian Sketches (Ippolitov-Ivanov); Burlesque (Culotta); Foxtrot (Escobar); Selection from Siberia (Giordano); Stelle filanti (Restelli). In the interval from 1.30 to 1.45, Time; Announcements. 4.30, Children's Radio Review. 4.55, News; Exchange; Lottery Results. 5.10, Vocal and Instrumental Concert; Claro Sardo (Pianoforte), Mary Luisa Sardo (Violin), Adelfo Zagonara (Tenor), and Giselda Bonitatibus (Soprano): Pianoforte Solos: (a) Gavotte (Lully), (b) Gigue (Rame); Tenor Solos: (a) Hindu Song (Rimsky-Korsakov), (b) Serenade from Iris (Mascagni), (c) Princesita (Padilla); Violin Solos: (a) Spanish Romance (Carnevali-Corti), (b) Marguerite (Rachmaninov-Kreisler), (c) Saltarelle (Wieniawski); Soprano Solos: (a) Margherita (Gallas), (b) Gotine gialle (Brogi), (c) Granadinas (Barrera-Galleja), (c) Aria from Il diavolo (Massenet). 5.55, Weather. 6.0 to 6.10, Corn Market. 7.0, Tourist Notes; Report of the Royal Geographical Society and Dopolaro Notes. 7.15, News in Foreign Languages. 8.0, Time; News. 8.10, Records. 8.30, Government Notes. 8.45, Comedy. News in the interval. 12 Midnight, Close Down.

RUYSELEDE

10,330 kc/s, 29.04 metres; 8 kW.—7.45 p.m., News in French. 8.0, See Brussels (No. 2). 9.0, News in Flemish. 9.15, Close Down.

SALZBURG.—Relays Vienna.

SCHENECTADY

WGy, 790 kc/s, 379.5 metres; 50 kW. Relayed at intervals by W2XAF on 31.48 metres; and by W2XAD on 19.56 metres.—7.0 p.m., Irving Aaranson and his Orchestra. 7.30, Week-end Revue; Variety Musicale. 11.25, Exchange. 12 Midnight, General Electric Programme. 12.30 a.m. (Sunday), Hands Across the Border. 1.0 to 3.0 a.m., Popular Programme.

SOTTENS

677 kc/s, 443.1 metres; 25 kW.; and Geneva, 401 kc/s, 748 metres.—7.0 to 7.15 a.m., Gym. 12.29 p.m., Time. 12.30, News. 12.40 (from Geneva), Records. In the interval at 1.0, Exchange. 2.0, Interval. 3.59, Time. 4.0, Report of the Geneva Walking Trials. 4.30 to 6.0, See Monte Ceneri. 6.0 (from Geneva), Programme for Children. 6.30 (from Geneva), English Lesson. 6.45 (from Geneva), Programme for Young People. 6.55 (from Geneva), Jazz Records. 7.5 (from Geneva), Hints for Ramblers. 7.15 (from Geneva), Film Review. 7.40, News. 7.59, Weather. 8.0, Talk with Musical Illustrations: Seventeenth and Eighteenth Century French Music and its influence on Foreign Composers. 8.35, Concert by the Station Orchestra; Conductor, Echenard; Septet (Beethoven). 9.0, News. 9.10 (from Geneva), Delmet and Hahn Song Recital by Nicolas Amato. 9.35, Concert (cont'd.); Light Music. 10.0, Report of the Geneva Walking Trials. 10.20 (from Geneva), Dance Music. 11.30 (approx.), Close Down.

STOCKHOLM

704 kc/s, 426.1 metres; 55 kW. Relayed by Boden and Osternund, 413.5 kc/s, 726 metres; Göteborg, 941 kc/s, 311.8 metres; Hörby, 1,131 kc/s, 265.3 metres; Motala, 216 kc/s,

1,389 metres; and Sundsvall, 601 kc/s, 499.2 metres.—7.20 a.m., Gym. 7.45, Service. 8.0, Weather. 12.30 p.m., Weather. 12.45, Exchange. 12.55, Time. 2.0, Orchestral Concert of Light Music. 3.0, Programme for Children, relayed from Örebro, 1,312 kc/s (228.7 metres). 3.30 (from Göteborg), Light Music. 4.30, Talk. 5.0, Weather. 5.5, Records. 5.45, Old Dance Music by Sven Skölds Band. 6.20, Relay of the Inauguration of the Göteborg Municipal Theatre. 7.15, News. 7.30, Records; Walter's Prize Song and Prelude, from The Mastersingers (Wagner). 7.45, Breaking Up—Play (Alicia Svensk). 8.15, Concert by the Station Orchestra; Conductor: Ivar Hellman; Soloist: Ally Hallman (Songs); Marek (Komzak); Overture, Die schöne Galathee (Suppé); Songs: (a) In Wien, wo der Wein und der Walzer blüht (Stolz), (b) A Viennese Waltz (Benatzky), (c) So küsst man nur in Wien (Abraham); German Dances (Schubert); Waltz (Reiml); Polka (Strauss); Vienna, City of my Dreams (Siczynski); Songs: (a) Aria from The Circus Princess (Kálmán), (b) Ich muss wieder einmal in Grinz sein (Benatzky); Fortissimo (Kálmán-Geiger); March (Blon). 9.45, News. 10.0 (from Göteborg), Dance Music. 11.0 (approx.), Close Down.

STRASBOURG

859 kc/s, 349.2 metres; 15 kW.—11.0, Concert from Grenoble, 968 kc/s, 309.9 metres. 12 Noon, Records. 12.45 p.m., News. 1.0, Time; Records. 1.15, Programme in German, relayed from the Ruins of the Château du Haut-Barr. 2.0, Interval. 2.30, Concert from Paris (Ecole Supérieure). 3.30, Talk on French Music. 3.45, Talk for Women. 4.0, Programme from Paris (Radio Colonial), 19.68 metres. 5.0, Richard Strauss Concert by the Station Orchestra; Conductor, de Villiers; Soloist, Poeyt (Horn); Don Juan; Concerto for Horn and Orchestra; Selection from Der Rosenkavalier. 6.0, French Lesson. 6.15, Talk in German for Farmers. 6.30, Talk: Czech Castles. 6.45, Orchestral Concert of Light Music; Conductor, Roskam (Cello); Marche Roumaine (Ganne); Waltz, Die Schönbanner (Lammer); Overture, Athalia (Mendelssohn); Selection from The Merry Wives of Windsor (Nicola); Cello Solos: Two Pieces (Filipucci). 7.30, Time; News. 7.45, Local News. 8.0, Press Review in German; Announcements. 8.30, Franco-Yugoslav Festival Programme, relayed from Nancy: The Yugoslav Choir of Merlebach and a Military Band; French and Serbian Songs. 10.30, News. 10.40, Dance Music from the Caveau de l'Aubette. 12 Midnight, Close Down.

STUTTGART

MUHLACKER, 574 kc/s, 522.6 metres; 100 kW.—5.35 a.m., Notes for Farmers. 5.45, Hymn; Time; Weather. 5.50, Gym. 6.15, Concert by the Philharmonic Orchestra, relayed from Karlsruhe; Conductor: Zelm. 6.40, Time; Announcements. 6.55, Records. 8.10, Weather. 8.15, Gym. 8.35 to 8.40, Water Level Report. 10.0, News. 10.10, Records of Viennese Schrammel Music. 10.30, Sonata (Haydn) by Hermann Klais (Cello) and Ely Ehrhardt (Pianoforte). 10.50, Aria Recital by Ines Metzger-Klunn (Contralto); Arias from Semiramis (Glück); Dieh preist, Allmächtiger, der Sterne Jubelklang! (Nicodé); Arietta (Pergolesi); Arietta (Marecello). 11.25, Announcements; Records. 11.55, Weather. 12 Noon, See Frankfurt. 1.0 p.m., News; Weather. 1.20, Records. 1.50, Time; News. 2.0, Records; Lustig und fidel (Diétrich); Freut euch des Lebens (Jos. Strauss); Lustige Herzen (Pokorny); Piece (Grunov); Waltz, Mein Lebenslauf ist Lieb und Lust (Jos. Strauss); Piece (Reverfing-Gruber); Liebchen ade (Niel). 2.30, Youth Hostels—Sequence for Young People. 3.10, Morse Lesson. 3.30, Lute Recital by Artur Faiss; Two Dances (da Parma); Suite (de Visée). 3.45, Talk: The German Race. 4.0, Concert by the Philharmonic Orchestra, relayed from Mannheim. 6.0, See Frankfurt. 6.20, Tally Ho!—Hunting Sequence (Held). 7.0, See Munich. 8.0, News. 8.5, Local Review. 8.10, See Munich. 10.0, Weather; Sports Notes. 10.20, News. 10.45, Dance Music by the Willi Wende Band. 12 Midnight, Concert. In the Interval, Fifteen Variations and Fugue in E Flat, Op. 35 (Beethoven), by Otto Sonnen. 2.0 a.m. (Sunday), Close Down.

SUNDSVALL.—Relays Stockholm.

TOULOUSE

913 kc/s, 328.6 metres; 10 kW.—8.0 a.m., Dance Refrains. 8.30, News. 8.35, Orchestral Music. 8.45, Songs. 12 Noon, Music by a Viennese Orchestra. 12.15 p.m., Opera Arias. 12.30, News; Exchange. 12.45, Request Music. 1.0, News. 1.5, Orchestral Music. 1.15, Sound Film Music. 1.30, Military Band Music. 1.45, Popular Songs. 2.0, Amusement Guide. 6.0, News. 6.15, Opera Music: Extracts from The Valkyrie (Wagner), Der Preischütz (Weber), Faust (Gounod), Tristan and Isolde (Wagner). 6.30, Songs. 6.45, Light Orchestral Music. 7.0, Soloist Programme. 7.15, Operetta

Music. 7.30, News; Racing Results; Wheat Market Prices; Exchange. 7.45, Light Music. 7.50, Talk. 8.15, Concert Version of Azor—Operetta (Gabaroché). 9.0, Light Orchestral Music. 9.15, Pianoforte Recital by Pitié. In the Interval; Songs by Malieet. 10.0, Sound Film Music. 10.15, News. 10.30, Military Band Music. 11.0, Request Music. 11.15, Opera Music: Extracts from Louise (Charentier). La Bohème (Puccini). 11.30, Operetta Music: Extracts from The Drum Major's Daughter (Offenbach), Louis XIV (Pares and Parys), Brummel (Habu), Frasquita (Lehár). 11.50, Choral Music. 12 Midnight, News. 12.5 a.m. (Sunday), Au caveau de Minuit—Radio Fantasia. 12.15, Orchestral Music: Adagio etto from Symphony No. 5 (Mahler); Norwegian Rhapsody (Lalo). 12.30, Close Down.

TRONDHEIM.—Relays Oslo. TURIN.—Relays Milan.

VATICAN CITY

15,120 kc/s, 19.84 metres; 10 kW. (Morning), 5,970 kc/s, 50.26 metres (Evening).—11.0 to 11.15 a.m., Religious Information in Various Languages. 8.0 to 8.15 p.m., Religious Information in Italian.

VIENNA

592 kc/s, 506.8 metres; 120 kW. Relayed by Graz, 886 kc/s, 338.6 metres; Innsbruck, 519 kc/s, 578 metres; Klagenfurt, Linz and Salzburg, 1,294 kc/s, 231.8 metres.—9.0 a.m., News. 10.50, Water Level; Weather. 11.30, Programme for Women. 11.55, Weather. 12 Noon, Records: Potpourri (Lindemann); Selection from La Vie Parisienne (Offenbach); Eysler Potpourri (Hrubý); Waltz from Die geschiedene Frau (Fall); Entry of the Little Fauns (Pierné); Faust Fantasia (Wieniawski); Torna a Sarricento (de Curtis); Offenbach Potpourri. 1.0 p.m., Time; News. 1.10, Records: Potpourri, Wiener Leben (Komzak); Song (Wood); Fahrt in den Wiener Wald (Joh. Strauss); Berceuse (Gretchaninov); Selection from Der arme Jonathan (Müllöcker); Española (Serrano); Selection from Rose Marie (Friml-Stöckart). 2.0, Announcements. 2.10, Records: Arias from La Juive (Halévy), The Bartered Bride (Smetana), I Pagliacci (Leoncavallo), and The Magic Flute (Mozart); Princesita (Padilla). 2.30, Interval. 3.0, Time; Weather; Exchange. 3.15, French Talk: Les cris de Paris. 3.40, Der Traum ein Leben—Play in Four Acts (Grillparzer). 5.30, News. 5.35, Concert by the Vienna Mandoline Society; Conductor, Schmidhuber; Overture, The Caliph of Bagdad (Boieldieu); Träumerei (Schumann); Gavotte, Schön Liebchen (Döpl); Faust Fantasia (Walter); Alex-Polka (Bass); Volksliedchen und Märchen (Komzak). 6.0, Relay of the Ceremony from the Seipel Dollfus Mausoleum—Transferring the Two Coffins to the Crypt. 8.0, Time News. 8.10, Dramatic Programme for the Tenth Anniversary of the Vienna Radio Station; Talk by Dr. Hans Nüchtern; 1924. Der Ackermann und der Tod —Dialogue (von Saaz); 1934, Red-White Red (Song of a Flag)—Sequence (on Records); Mary Stuart in Scotland—Play (Marie von Ebner-Eschenbach). 10.30, News. 10.50, Dance Music. 12 Midnight, Dance Records. 1.0 a.m. (Sunday), Close Down.

WARSAW

223 kc/s, 1,345 metres; 120 kW.—6.45 a.m., Hymn. 6.48, Records. 6.58, Gym. 7.8, Records. 7.15, News. 7.25, Records. 7.35, Hints for Housewives. 7.40, Programme Announcements. 7.50, Announcements; Light Music. 8.0, Interval. 11.57, Time. 12 Noon, Fanfare from St. Mary's Church, Cracow. 12.3 p.m., Weather. 12.5, Press Review. 12.10, Concert by the Nina Maska Ensemble: Waltzes from The Bayadere (Kálmán); En Japon (Gauvin); Two Pieces (Nieman); The Nightingale and the Rose (Rimsky-Korsakov); Intermezzo and Air from The Czar's Bride (Rimsky-Korsakov); La quenouille de Bonne-Maman (Gillet); Serenade (Carosio); The Musical Snuff Box (Nikolajevsky); Twilight (Bece); Minuet (Godard); Serenade (Gauvin). 1.0, News. 1.5, Opera Records. 1.30, Interval. 3.30, Announcements. 3.35, Exchange. 3.45, Records. 4.30, Dramatic Programme from Lwów, 795 kc/s, 377.4 metres. 5.0, Recital by Hoffman (Mezzo-Soprano) and Sznajderman (Violin); Violin Solos: (a) Nocturne in F sharp minor (Rozycki) (b) Slav Dance in G minor (Dvorák-Kreisler). (c) Hebrew Melody (Achron); Songs: (a) Nocturne (Chausson). (b) Le temps des lilas (Chausson). (c) Song (Mahler); Violin Solos: (a) Berceuse (Straivinsky), (b) Caprice (Wieniawski), (c) Moto perpetuo (Paganini); Songs: (a) In the Silent Night (Rimsky-Korsakov), (b) Le vergé fleur (Arenski), (c) The Roses (Cezek). 5.50, Programme for Women. 6.0, Programme for Farmers from Wilno, 536 kc/s, 559.7 metres. 6.10, Art Notes. 6.15, Sonata in D Op. 18 for Cello and Pianoforte (Rubinstein) relayed from Lwów. 6.45, Report. 7.0, Dance Music from the Adria Café. In the interval at 7.20, Talk from Poznań, 868 kc/s, 345.6 metres. 7.45, Programme Announcements. 7.50, Sports Notes. 8.0, Talk: War Reminiscences. 8.15, Announcements; Light Music. 8.30, Talk on the following Relay. 8.45, See Rome. In the interval, News. 11.20, Weather. 11.25, Humorous Programme. 11.55, Dance Music from the Gastronomia Restaurant. ZÜRICH.—Relays Beromünster.

PRINCIPAL BROADCASTING STATIONS OF EUROPE

Arranged in Order of Frequency and Wavelength

(Stations with an aerial power of 50 kW. and above in heavy type)

Table with 4 columns for each station set: Station, kc/s., Tuning Positions, Metres, kW. The table lists major European broadcasting stations including Kaunas, Paris, Moscow, Berlin, and London, along with their respective frequencies and powers.

SHORT-WAVE STATIONS OF THE WORLD

(N.B.—Times of Transmission given in parentheses are approximate only and represent G.M.T.)

Metres.	kc/s.	Call Sign.	Station.	Tuning Positions.	Metres.	kc/s.	Call Sign.	Station.	Tuning Positions.
58.31	5,145	OK1MPT	Prague (Czechoslovakia). (Experimental)	31.38	9,560	DJA	Zeesen (Germany). (Daily 11.45 and 22.00)
50.26	5,969	HVJ	Vatican City, Rome. (Daily 19.00, Sun. 10.00 also.)	31.35	9,570	W1XAZ	Springfield, Mass. (U.S.A.). (Relays WBZ.) (Daily 11.00, Sun. 13.00.)
50.0	6,000	RW59	Moscow. (Relays No. 1 Stn.) (Daily 21.00)	31.30	9,585	GSC	Empire Broadcasting
50.0	6,000	EAJ25	Barcelona, Radio Club (Spain). (Daily 20.30.)	31.28	9,590	W3XAU	Philadelphia, Pa. (U.S.A.). (Relays W.C.A.U.) (Daily 16.00.)
49.83	6,020	DJC	Zeesen (Germany). (Daily 17.30 and 23.45)	31.28	9,590	VK2ME	Sydney (Australia). (06.00, 10.00 and 14.30.)
49.67	6,040	W1XAL	Boston, Mass. (U.S.A.) (Daily ex Sun. 21.45, Sun. 00.00)	31.27	9,595	IBL	Radio Nations, Prangins (Switzerland). (Sat. 22.30.)
49.67	6,040	W1XNB	Miami Beach, Florida (U.S.A.) (Daily 12.00.)	31.25	9,600	CT1AA	Lisbon (Portugal). (Tues. and Fri. 20.30.)
49.59	6,050	GSA	Empire Broadcasting	30.43	9,860	EAQ	Madrid (Spain). (Daily 22.30, Sat. 18.00 also.)
49.5	6,060	W3XAU	Philadelphia, Pa. (U.S.A.). (Relays W.C.A.U.) (Daily 00.00.)	28.98	10,350	L8X	Buenos Aires (Argentina). (Daily 20.00)
49.5	6,060	VQ7LO	Nairobi (Kenya Colony). (Daily ex Tues. and Thurs. 16.00, Tues. 08.00, Thurs. 13.00.)	26.83	11,181	CT3AQ	Funchal (Madeira). (Sun. 15.30, Tues. and Thurs. 22.00.)
49.5	6,060	OXY	Skamlebaek (Denmark). (Relays Kalundborg.) (Daily 19.00.)	25.63	11,705	FYA	Paris, Radio Coloniale (France). (Colonial Stn. E-W. Daily 02.00, 19.00 and 22.15.)
49.43	6,069	VE9CS	Vancouver, B.C. (Canada). (Sun. 16.00, Sat. 04.30.)	25.6	11,715	VE9JR	Winnipeg (Canada). (Daily 00.00)
49.34	6,080	W9XAA	Chicago, Ill. (U.S.A.). (Relays W.C.F.F.) (Daily ex Sun. 19.00, Sun. 15.30.)	25.57	11,730	PHI	Eindhoven (Holland). (Temporarily suspended.)
49.22	6,095	VE9GW	Bowmanville, Ont. (Canada). (Sun. 16.00, Mon., Tues., Wed. and Thurs. 18.00, Fri. and Sat. 12.00.)	25.53	11,750	GSD	Empire Broadcasting
49.18	6,100	W3XAL	Bound Brook, N.Y. (Relays W.J.Z.) (Mon., Wed. and Sat. 21.00.)	25.51	11,760	DJD	Zeesen (Germany). (Daily 01.45, 17.30, 22.00.)
49.18	6,100	W9XF	Chicago, Ill. (U.S.A.). (Tues., Thurs. and Fri. 21.30, Fri. and Sat. 02.30.)	25.4	11,810	2RO	Boston, Mass. (U.S.A.). (Daily ex Sun. and Sat. 22.00, Sat. 23.30.)
49.1	6,109	VUC	Calcutta, India. (Daily ex Fri. and Sat. 15.30, Fri. 14.30, Sat. 17.45.)	25.36	11,830	W2XE	Trato Smeraldo, Rome. (Daily 15.00 and 21.00.)
49.02	6,120	W2XE	Wayne, N.J. (U.S.A.). (Relays W.A.B.C.) (Daily 22.00.)	25.29	11,860	GSE	Wayne, N.J. (U.S.A.). (Relays W.A.B.C.) (Daily 19.00.)
49.0	6,122	ZTJ	Johannesburg (S. Africa). (Daily ex Sun. and Sat. 04.45, 08.30, 14.00, Sun. 13.00, 17.30, Sat. 14.00.)	25.27	11,870	W8XK	Empire Broadcasting
48.86	6,140	W8XK	Pittsburg, Pa. (U.S.A.). (Relays KDK.A.) (Daily 21.30.)	25.25	11,880	—	Pittsburg, Pa. (U.S.A.). (Relays KDK.A.) (Daily 15.00.)
48.0	6,250	HJ3ABF	Bogota (Colombia)	25.0	12,000	RNE	Paris, Radio Coloniale (France). (Colonial Stn. N-S. Daily 15.45 and 19.00.)
48.69	6,425	W3XL	Bound Brook, N.J. (U.S.A.). (Experimental)	23.39	12,825	CNR	Moscow. (Relays No. 2 Stn.) (Sun. 04.00, 11.00 and 15.00.)
45.38	6,610	RW72	Moscow. (Relays Stalin Stn.) (Mon., Wed., Fri. and Sat. 21.00.)	19.84	15,123	HVJ	Rabat (Morocco). (Sun. 11.30)
45.0	6,667	SKR	Constantine (Algeria)	19.82	15,140	GSP	Vatican City, Rome. (Daily 10.00)
43.0	6,976	EA1110	Madrid. (Tues. and Sat. 22.00)	19.73	15,200	DJB	Empire Broadcasting
40.3	7,444	HBQ	Radio Nations, Prangins (Switzerland)	19.72	15,210	W8XK	Zeesen (Germany). (Daily 05.35 and 12.45)
38.48	7,797	HBP	Radio Nations, Prangins (Switzerland). (Sun. 22.30.)	19.68	15,243	FYA	Pittsburg, Pa. (U.S.A.). (Relays KDK.A.) (Daily 15.00.)
37.33	8,935	CNR	Rabat (Morocco). (Sat. 20.00)	19.56	15,330	W2XAD	Paris, Radio Coloniale (France). (Colonial Stn. E-W.) (Daily 12.00.)
36.65	8,186	PAR3	Rio de Janeiro (Brazil). (Daily 00.00)	16.89	17,760	DJE	Wayne, N.J. (U.S.A.). (Relays W.A.B.C.) (Daily 15.00.)
31.55	9,510	VK3ME	Melbourne (Australia). (Wed. and Sat. 10.00.)	16.88	17,770	PHI	Schenectady, N.Y. (U.S.A.). (Daily 19.00)
31.55	9,510	GSB	Empire Broadcasting	16.87	17,780	W3XAL	Zeesen (Germany)
31.48	9,530	W2XAF	Schenectady, N.Y. (U.S.A.). (Relays W.G.F.) (Daily 23.35.)	16.86	17,790	GSG	Empire Broadcasting
					13.97	21,470	GSH	Empire Broadcasting
					13.93	21,540	W8XK	Pittsburg. (Daily 12.00)

The Short-Wave World

The Malta Question — Indirect Ray or Ground Wave ?

TWO readers in Malta have now added their quota to the mild controversy concerning the reception of the Empire station in that part of the world. The gentleman who wrote originally is strongly opposed to the idea that—to quote this column—"real short-wave reception by reflected ray hardly enters into the matter." He says definitely that signals show all the signs of reception by indirect-ray—high-speed and differential fading, etc.

The other writer waxes indignant at the implied suggestion that ground-wave reception on such a short wave was possible at a distance of 1,400 miles!

As a matter of fact, it was not put particularly clearly in the first instance, and the writer of these notes bows before the storm. What he *did* mean to imply was that Malta was not sufficiently far from the various European short-wave stations for an accurate reproduction of the characteristic phenomena of long-distance reception to be obtained.

The Difference

Reception, needless to say, must be by the indirect ray, but the severe periodical variations in conditions that one experiences at 4,000 or 5,000 miles are almost entirely absent at a distance of 1,400 miles. A case

in point that fits almost perfectly is that of amateur work between this country and Finland.

On the 14-mc. band there is definitely no doubt that the indirect ray comes into the question; but Finland may be heard reliably on nights when the U.S.A. (or, to keep to the same direction, even Russia) is completely blank.

It is, paradoxically, on nights when general conditions seem specially good that the Finns, 1,000 miles away, cannot be heard. Skip-distance and its variations form the basis of the whole subject.

In other words, though the relative distances of Zeesen, Radio-Coloniale, and the Empire station are very different in Malta and in South Africa, it would be possible for the same proportional strengths of transmission to hold good.

It would be interesting to hear how the various U.S.A. stations are received in Malta and to compare the reports with others from this country. Just at the time of writing, the best transmission (strangely enough) has been from W1XAZ on the 31-metre band.

The *Wireless World* "1935" A.C. short-wave receiver will shortly be installed by the writer as a kind of permanent "check" receiver, and will remain unaltered as long

as it continues to function satisfactorily. It should be possible to announce, in advance, one-hour periods of searching, and to get readers to keep watch at the same time.

It is only by organised checking work of this kind that it is possible to collect any useful data concerning local conditions. At present a commercial six-valve superhet is being used, together with the "stand-by" two-valve battery set which has been in use since 1928 without alteration!

Background Hiss

Several transmissions which have been swamped by "background" on the superhet have been received quite clearly on the smaller receiver. This always has been the case, and probably will be for some time to come; "filament-hiss," though reduced to an extremely small figure, still continues to exist in sufficient proportions to embarrass the short-wave enthusiast.

The superhet has quite an audible background when the aerial is removed and the whole thing is put out of tune; in fact, with everything in front of the second detector switched off, there is a background hiss that one might describe as "R2." With the battery set not a sound can be heard when the detector is not oscillating.

MEGACYCLE.

Broadcast Brevities

By Our Special Correspondent

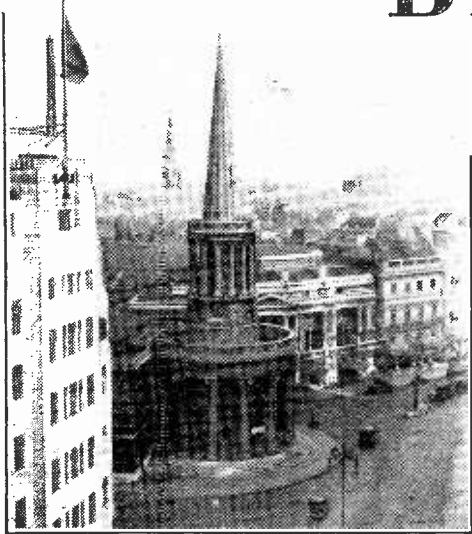

Maida Vale Testing

WITHIN a week or two engineers will set out for Maida Vale—not a long journey, but romantic nevertheless. There, in Delaware Road, they will begin testing the acoustics of the redesigned skating rink. Lines already connect the new studio with Broadcasting House, and the engineers in the control room at headquarters will soon be carefully recording their impressions, during tests with various musical instruments and small choral combinations.

On the Air Next Month

At the end of October "Maida Vale" will take its place among the other famous outside studios of the B.B.C. It will probably be on the air by that time.

Strangely enough, it may not be used very extensively at first for, contrary to the original intention, No. 10 studio is being retained for another year and can be used at all times when actual demolition work is not proceeding on Waterloo Bridge.

"No. 10" to Continue

THE "Warehouse," as No. 10 is called, is very popular with artists. Despite the uncongenial surroundings, the interior of this old warehouse is extremely inviting and comfortable and gives the visitor the impression of being in Broadcasting House itself.

The Wireless Chorus invariably rehearses in No. 10.

Mobile Recording Service

THAT the B.B.C. will shortly operate a radio reporting service with mobile recording apparatus is no longer a matter of doubt. All that remains to be settled is the system to be used. Mr. Gerald Cock has a wide selection of methods from which to choose, including wax discs, film, and metal tape. In all probability he will choose the last-named.

A Lesson from Germany

The Germans have brought radio reporting to a fine art; indeed, so frequent has been the inclusion of these potted "O.B.s" in the programmes that of late there has been a reaction against them. Noise without vision seldom satisfies for long, and the Germans seem to have exhausted the whole gamut of sounds, from the launching of a ship to the reading of the Riot Act,

Editing an "O.B."

Undoubtedly the potted version of an "O.B." can be put over more artistically than the extempore record. Subsequent editing of the record goes a long way towards heightening the interest of the programme by the deletion of unnecessary passages. In many respects the process is the same as that at the film editing bench.

With the adoption of mobile recording it seems likely that a new editing department will be needed at Broadcasting House.

B.B.C. Orchestra's Provincial Tour

THE Provinces have been singularly patient in the matter of broadcast orchestras. Their patience will be rewarded during the coming season when the B.B.C. Symphony Orchestra, under the direction of its conductor, Adrian Boult, will visit the Free Trade Hall, Manchester (December 5th); the Colston Hall, Bristol (February 13th); the Town Hall, Birmingham (February 27th); and the Caird Hall, Dundee (April 2nd).

Public Performances

The halls will be thrown open to the public and listeners in these areas will therefore be given the opportunity of hearing the orchestra at first hand.

No doubt the performances will be broadcast, but it is hardly fair to the B.B.C. to draw attention to this point. The B.B.C. wishes to fill the halls!

The orchestra is to visit Brussels on March 12th.

A Firm Foundation

THE "Foundations of Music" are as firmly established as ever. Perhaps no other section of the B.B.C.'s activities has been so often excommunicated by a certain class of critic with so little result.

The new "Foundations," which began this week, are directed by no less important a person than Sir Richard Terry, the eminent authority on Tudor and early church music. Under the title, "From Plainsong to Purcell," broadcasts are being given nightly from Monday to Friday each week.

For All to Hear

The ground covered by Sir Richard Terry's series includes plainsong, folksong and the early polyphonic music derived from these sources. Tudor music will be heard as well as old keyboard music and Elizabethan folk songs.

The time-table is to be slightly altered. On Tuesdays and Thursdays the programmes will be broadcast from 6.30 to 6.50 p.m., as previously, and on Mondays, Wednesdays

and Fridays they will be given from 7.5 to 7.25 p.m., thus making it easier for those whose daily work takes them away from their homes to hear the series.

Back to Beethoven

RETURNING from summer holidays, the B.B.C. Chorus of two hundred and sixty amateur voices, goes into rehearsal this week for its first performance of the season at the Queen's Hall on October 5th, when, in a Promenade Concert, it will be heard in the Choral Fantasia and the ninth Symphony, by Beethoven.

The Chorus, consisting of eighty-five sopranos, fifty-five contraltos, fifty tenors, and seventy bass voices, rehearses on Friday evenings throughout the season.

Dancing in the Studio

A PROGRAMME of pre-war dances to be broadcast on the London Regional wavelength on October 1st extends an invitation to listeners in its title: "You are invited to Dance!" This programme will be given by the B.B.C. Theatre Orchestra, conducted by Stanford Robinson, and the M.C. in the studio will be Philip J. S. Richardson. During the broadcast, dances will be performed in the studio and Mr. Richardson will describe them to listeners, who will be able to step in time with dancers in the studio.

The programme will include such old favourites as the Veleta, Barn Dance, Lancers, Sir Roger de Coverley and three types of Waltzes. These are Amoretentanza, the fast "hoppy" type danced in the 'nineties and the early days of the present century; the Choristers, which was the slow waltz in vogue about 1900; and the Archibald Joyce waltz, which was danced everywhere before the war.



EFFECTS IN THE RAW.—No toy trumpets or half coconuts satisfy the "effects" engineers at Budapest. Here is an engineer getting the actual sounds for a "Down on the Farm" programme.

Things We Want to Know

WHETHER the B.B.C. has closed the list of free admission to the variety concerts in St. George's Hall.

Whether the last people on the present list will have to wait two years for admission.

Whether the admission tickets are therefore transferable to their descendants.

Letters to the Editor

Cinema Quality

Reception of B.B.C. Empire Station : Service and Compactness : Iron-cored Coils

The Editor does not hold himself responsible for the opinions of his correspondents

Cinema Quality

AS a film recording and reproduction engineer I much appreciate the points of view expressed by Mr. H. R. Wilkinson (Enfield) in your issue of August 31st, 1934. Certainly to an experienced "L.F. man" cinema reproduction frequently leaves much to be desired, and one rather naturally puts a large amount of blame on to the theatre's outfit, and/or the operators thereof. I must utterly disagree, however, with Mr. Wilkinson when he says that the obvious trouble is pure overloading in one or more stages. He must look much deeper into the matter than this and make his inspections much farther away than the theatre's picture booth.

By far the weakest link in the chain between studio microphone and theatre reproducer is the point where the sound is put on to film, is developed, is printed, is often re-recorded and "mixed," is re-developed and reprinted. Anyone with knowledge of emulsion curves and development and printing curves might well express amazement that the final theatre sound was better than "just intelligible." Even when the enormous difficulties of this link have been satisfactorily overcome, it only requires a small amount of stray oil on the sound track, or the slightest mechanical scratch to once more ruin the result. The average theatre reproducing equipment is capable of giving the finest possible performance, but has the thankless task of making something very good from a far-from-perfect input.

Bouquets of two distinct varieties are frequently handed to sound men and reproducing equipment people, but never do we hear of the wonderful chemists and laboratory people who work unceasingly on the biggest of all problems in connection with cinema quality.

In conclusion, I should like to point out to Mr. Wilkinson that so many precautions have been taken in the design of theatre equipment, that it would be a difficult matter for even the most clumsy operator to cause distortion from overloading. And the majority of operators are the most conscientious fellows available. *But*—they are *not allowed* to touch in any way their equipments, except for the replacement of valves, etc. A highly competent service man pays a frequent and *compulsory* visit to every theatre, and thus the possibility of there existing anything like a serious fault or inherent defect in an equipment is rendered exceedingly unlikely.

Wishing long-lived success to your journal, which is "read" and understood by many French engineers here.

LAURENCE E. COUSSELL.

Paris.

AS a regular reader with a firmly established faith in the *Wireless World* I was very interested to see an article in my copy of your paper on Quality of Cinema Reproduction. It has been a constant

amazement to me why cinemas have not been the leaders in the world of quality reproduction instead of being, in my opinion and in the opinion of many others, very far from the ideal. I have visited a large number of luxurious and "not so luxurious" cinemas up and down the country, and I can truthfully say I have only been in one in which the reproduction was anything like good quality. I think the reason for this is that on account of the small size of the place the proprietors were not endeavouring to get a large output from the amplifiers at the expense of quality, which, I think, is the failing of many.

I noticed in another journal an article in which a talkie engineer was pulling to pieces a previous article by a wireless engineer and musician who is highly respected by those interested in good quality reproduction. He was using as one of his arguments that his facts were correct (against the perhaps somewhat unorthodox but highly satisfactory circuits of the wireless-cum-musician engineer) by saying that talkie amplifiers were of the highest standard and that as a result the quality of reproduction of the cinemas was very high.

Perhaps this talkie engineer is so busy with his "High Quality Reproduction" that he has no time to study music, etc., as it is in actual life; if so, surely he would not be so cocksure of the quality of reproduction of his cinemas.

Long may you uphold the interests of all those interested in reproduction as it really should be.

W. O. ROBERTS.

Chorlton-cum-Hardy,
Manchester.

Reception of B.B.C. Empire Station

AT the last monthly meeting of this Society a short article in your issue of July 6th, headed "The Short-wave World," and signed "Megacycle," came under discussion. Towards the end of the article in question reference is made to a letter received from a South African listener, and a reader would gather from what is said that the reception of Daventry in this country is excellent, but that that of Zeesen and Radio Coloniale is *usually* better still.

The article also refers to several South African readers having reported the Empire station as the best of all the Europeans.

I am directed to report that, although for patriotic reasons this Society would be only too happy to endorse the above reports, the unanimous feeling here is that, whatever may have been the state of affairs six or eighteen months ago, the above does not now represent the actual reception by the

general body of short-wave listeners here—the unanimous opinion of those who frequently check off the comparative volume and quality of the three leading short-wave stations which reach us between 18.00 and 23.00 o'clock being that the one station which stands out prominently in advance of both the others is the one which announces itself as "the German short-wave station, using a directional antenna to Africa." In the 25m. band up to, say, 18.00 G.M.T., or on the 49m. band for the rest of the evening, it comes through with such power that X's may often be regarded as absolutely negligible.

Radio Coloniale ranks next, though Daventry *sometimes* presses it hard for second place.

The quality of the German station is excellent, but that of the other two can seldom be appreciated owing to the ratio of their power to X's being insufficient to submerge the latter.

In these circumstances, it is felt that in the interests of all whose loyalty and patriotism to the old country desire the home station to be the leading short-wave station of the world, only harm can be done by misleading reports of freak or unusual reception, and that it is only when made acquainted with the true facts of general reception that Daventry can be expected to trace its weak spots and compete with its rivals.

GEO. H. JOHN SADLER,

Hon. Sec. and Treasurer, Radio Society
of South Africa, Cape Town.

[Other letters in the same strain have been received.—Ed.]

Service and Compactness

AS a radio engineer mostly engaged on service work, I particularly welcomed the recent reference in your Editorial to the absurd compactness of many commercial broadcast receivers. This unnecessary cramping of the mechanical design (the cabinets are usually of ample proportions) is as useless as it is exasperating, and its elimination by the manufacturers concerned would make sets in general more reliable, and would help considerably the servicing of them afterwards. The majority of radio manufacturers design their sets without any regard to accessibility, and when their products develop faults (which they invariably do) much time and energy is spent in getting at the "innards."

Apart from the general tendency to reduce chassis area to about two-thirds that allowed by the cabinet (sheer idiocy this), some makers still fit coils whose screening cans are soldered up. Others still use bits of bent wire and brass for switches. Some manufacturers fit a really good switch, but so hem it in by other components and wires that it is next to impossible to adjust it. Quite a few makers use plug-and-socket connection between speaker and chassis, but make the speaker leads so short that the chassis, when removed from the cabinet, cannot be connected to the speaker. These

Correspondence, which should be as brief as possible, should be addressed to the Editor, "The Wireless World," Dorset House, Stamford Street S.E.1., and must be accompanied by the writer's name and address.

are just a few points at random which the long-suffering service man has to contend with, and among many other things I have often wondered why the manufacturers do not give us more substantial aerial and earth connections than the dainty wander plugs so often supplied.

J. GIBBONS, A.M.I.R.E.

Stoke-on-Trent.

Iron-cored Coils

THE reply by Messrs. Collinson, Fillmore, and Rees to criticisms directed against the iron-core coil should be sufficiently convincing to call for no further comment. There is, however, one point which might prove a loophole in the argument in favour of the iron coil, but this possible defect has been shown, as a result of very careful investigation, to be non-existent.

I refer to the matter of temperature coefficient and maintenance of permeability. In the case of an air coil the expansion of the materials is invariably followed by an equal and opposite contraction. Temperature variation will, therefore, affect all coils similarly, and they will all return to their previous values.

This may or may not be the case with an iron-core coil, and it depends upon the manner in which the core is fixed and the process by which it is made. I believe I am correct in stating that a large proportion of iron-core coils used in this country are made from carbonyl iron.

Tests conducted in many laboratories show that the permeability does not tend to vary, and there appears to be no ageing. In the manufacture of many iron cores an artificial ageing process is employed, particularly when the cores are bakelite pressed.

Very careful tests have been carried out with modern types of iron core, and in each case it has been found that the magnetic

Wireless on Gliders

Lessons by Radio for the Flying Student

ONE of the biggest problems in gliding is being solved by wireless. All gliders have to be flown solo, and the student must, therefore, learn his lessons alone. Now, however, with the aid of short-wave communication between tutor and student, the latter gains confidence and becomes competent in a very short time.

These photographs, taken in the Rhön district, near Frankfurt, tell their own story. Three Telefunken

transmitters are operated on wavelengths between 60 and 100 metres. Two of them are for Morse transmission, and are operated by batteries. Their output is 1 watt. The third, which has an output of 20 watts, obtained from a foot genera-

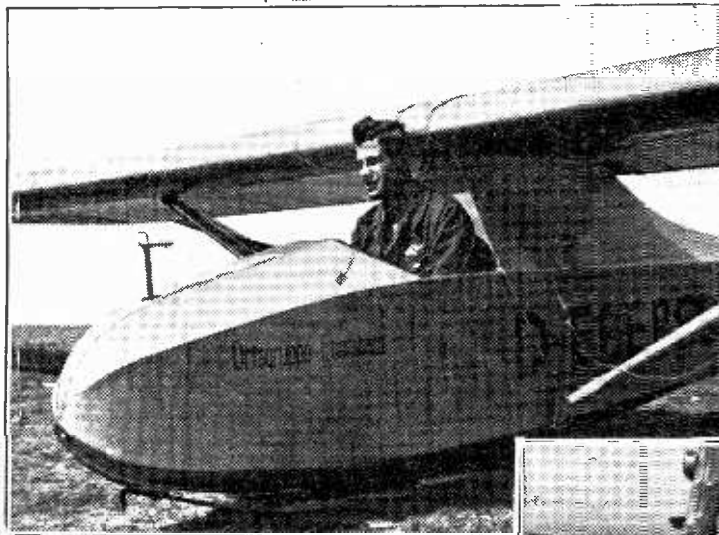
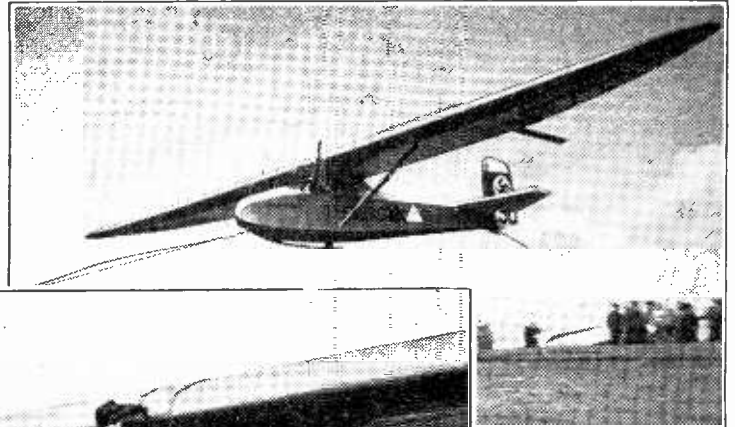

tor, is used for telephonic tuition.

The glider has a four-valve receiver, weighing only 7lb. Raw beginners depend on loud-speaker reception,



The 20-watt Telefunken 'phone set in use. Power is being derived from the pedal generator.

A well-known gliding expert, Carl Bloch. Note the aerial on the right, which extends some 20ft. to the tail of the glider. (Inset above) A radio-equipped glider is seen commencing a flight. (Right) Telephonic reception on the ground. (Below) Keeping in touch by means of the 20-watt transmitter.

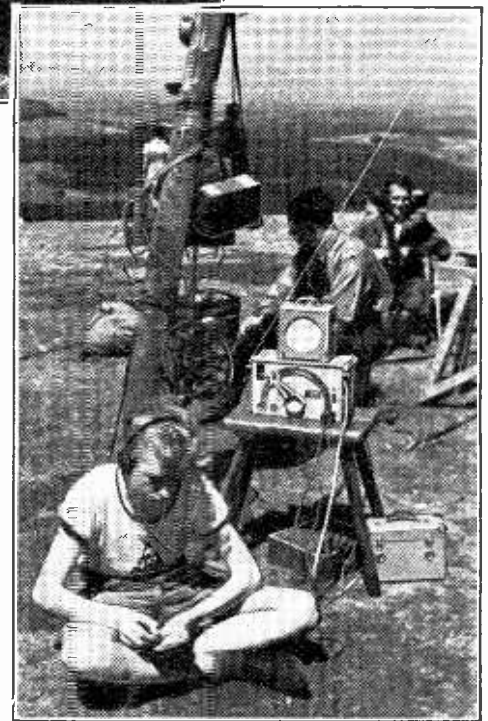

but more seasoned flyers rely on head-phone equipment clamped to their flying helmets.

Signal strength, even with the low-powered outfits, is adequate for the distances likely to be covered by novices.

properties of the cores remain constant, and the temperature coefficient is also constant and reversible.

These facts, I think it will be agreed, when considered with the points raised by your contributors, definitely prove the superiority of the iron-core coil. PAUL D. TYERS.

Watford, Herts.



Philips Superinductance Receiver

TYPE 472A

A Fine Example of Modern Practice in "Straight" Receiver Design

FEATURES.—*Type.*—Five-stage "straight" receiver for operation from A.C. mains. *Circuit.*—Two variable- μ H.F. stages with four tuned circuits—diode detector with A.V.C.—pentode L.F. amplifier—power pentode output valve Full-wave valve rectifier *Controls.*—(1) Tuning with Micro-Index dial (2) Wave-range and on-off switch. (3) Volume control (4) Tone control **Price.**—15 guineas. **Makers.**—Philips Lamps Ltd., 145, Charing Cross Road, London, W.C.2.

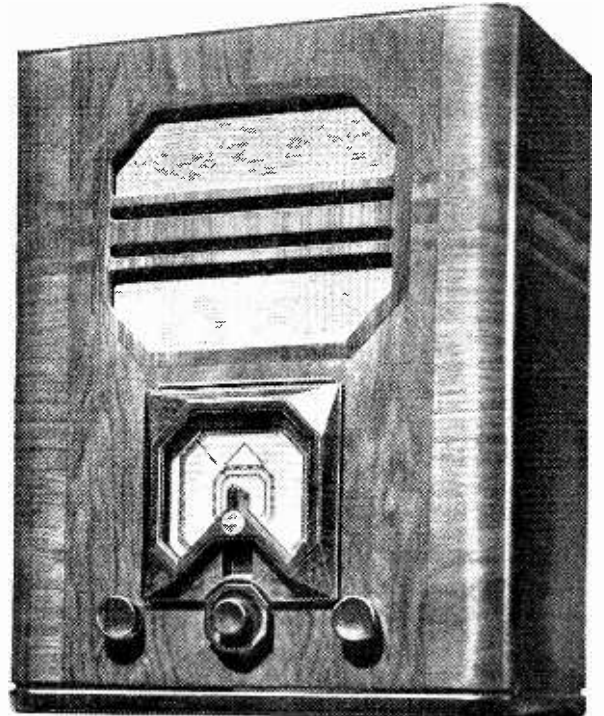

IT is generally conceded that the makers of this receiver are among the leading exponents of the principle of "straight"

H.F. amplification as applied to broadcast reception, and although this year a superheterodyne set is included in their programme it is evident from the numerous improvements incorporated in the remaining straight sets that they have no intention of abandoning what is undoubtedly a very sound principle.

In a straight receiver the attainment of a degree of sensitivity and selectivity comparable with a superheterodyne is by no means easy, involving as it does the solution of tricky problems of ganging and stability in the H.F. circuits. The labour involved, however, is amply repaid by a complete absence of self-generated whistles and a reduction of background noises

have greatly improved in this respect during the past year.

The makers have ensured that the initial advantages in the matter of background noise which the straight type of circuit provides shall not be prejudiced by interference through the power supply. Exceptionally efficient smoothing is provided, and high-frequency choke coils are included in the mains leads. The clarity with which the five or six foreign programmes which are available on medium waves during the hours of daylight stand out from the inevitable minimum of noise level provides immediate proof of the success which has attended the aims of the designers. Further, the sensitivity is such that adequate volume is obtained from these stations with the control at less than two-thirds of its maximum range, which results in a still further reduction of background noise.

There is no evidence of instability at the lower end of the medium waveband, and there is no lack of sensitivity near the top of the wave range. The degree of automatic volume control is adequate, though some attention to the manual control is necessary when receiving the local station. No criticism is possible on the score of selectivity, for in Central London the Brookmans Park transmitters do not encroach more than one channel on either side of their correct setting. On long waves the Deutschlandsender is easily separated from Daventry and Radio-Paris.

A larger output valve and an entirely new permanent-magnet moving-coil loud speaker have, in our opinion, resulted in a very considerable improvement in quality by comparison with last year's model. The bass response is not so prominent, and if any criticism is possible it is that the brilliance of the high-note response shows a tendency to hardness. This, however, is a matter of personal opinion, and in any case is easily rectified by the use of the

tone control. On the long-wave range the full range of top response is required, as there is evidence of slight side-band cutting.

Sensitivity Compensation

The circuit includes four "Superinductance" circuits of the well-known Philips design in which litz-wire is wound on a cylindrical glass former. The first two circuits are arranged as an input band-pass filter, and the remaining two are associated with the variable- μ H.F. pentode amplifying valves. The initial bias of both these stages is controlled by a potentiometer ganged to the main tuning control, and arranged to give uniform sensitivity over the tuning range of the set. Rectification is by means of a separate diode valve from which A.V.C. bias is applied to the first

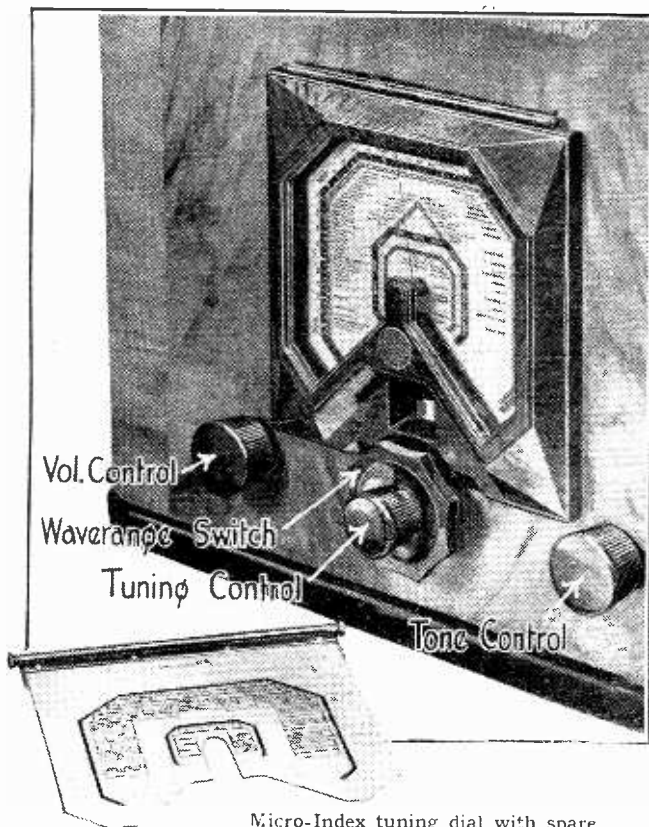

Micro-Index tuning dial with spare station-indicating plate.

generally. Heterodyne whistles between stations cannot, of course, be eliminated except by the use of the tone control and a corresponding loss of quality, but there can be no doubt that conditions in the ether

and if any criticism is possible it is that the brilliance of the high-note response shows a tendency to hardness. This, however, is a matter of personal opinion, and in any case is easily rectified by the use of the

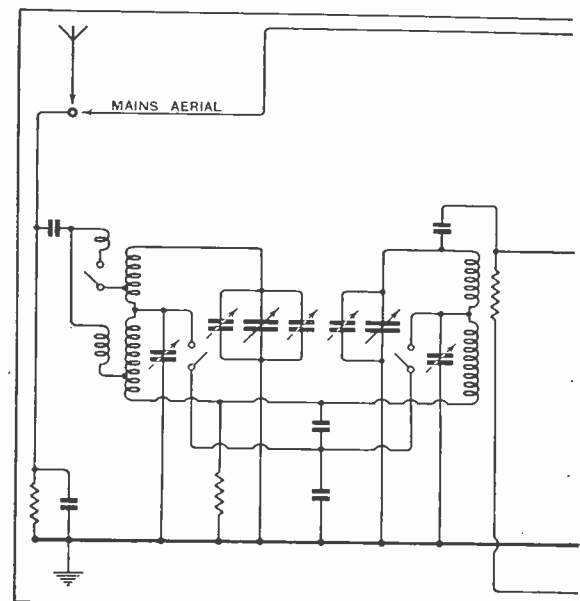

Complete circuit diagram. The automatic volume control

FIVE-VALVE A.C. MAINS "STRAIGHT" RECEIVER

H.F. stage. The diode is followed by a pentode L.F. amplifier which not only increases the overall sensitivity of the set but also ensures an adequate input to the final stage from weakly modulated transmissions. Elaborate precautions are taken to prevent H.F. reaching the output valve, which is a pentode rated to dissipate 8 watts. The tone control is connected across the primary of the output transformer, and a switch is included in the secondary circuit to cut out the internal loud speaker when only the extension loud speaker is required. A full-wave rectifier is used in the power supply, and the voltage drop in the smoothing choke, which is connected in the negative lead, provides bias for the output valve.

The controls are simple to operate, and the open tuning scale is very accurately calibrated in wavelengths. Interchangeable station-indicating dials are provided, one giving a selection of the principal European transmissions, the other being closely calibrated with the name of every station which is likely to be received. The wave-range switch is concentric with the main tuning control, and the setting of the switch is indicated by lettering which appears at a small window below the main

tuning dial. The set is provided with an efficient mains aerial, and a safety plug incorporated in the back panel ensures that current is cut off before access can be obtained to the back of the set.

The cabinet work is sound and the finish

will pass the most critical inspection. From every point of view the purchaser will get very full value for his money, and he need anticipate no feeling of inferiority when discussing performance with owners of super-heterodynes of comparable size.

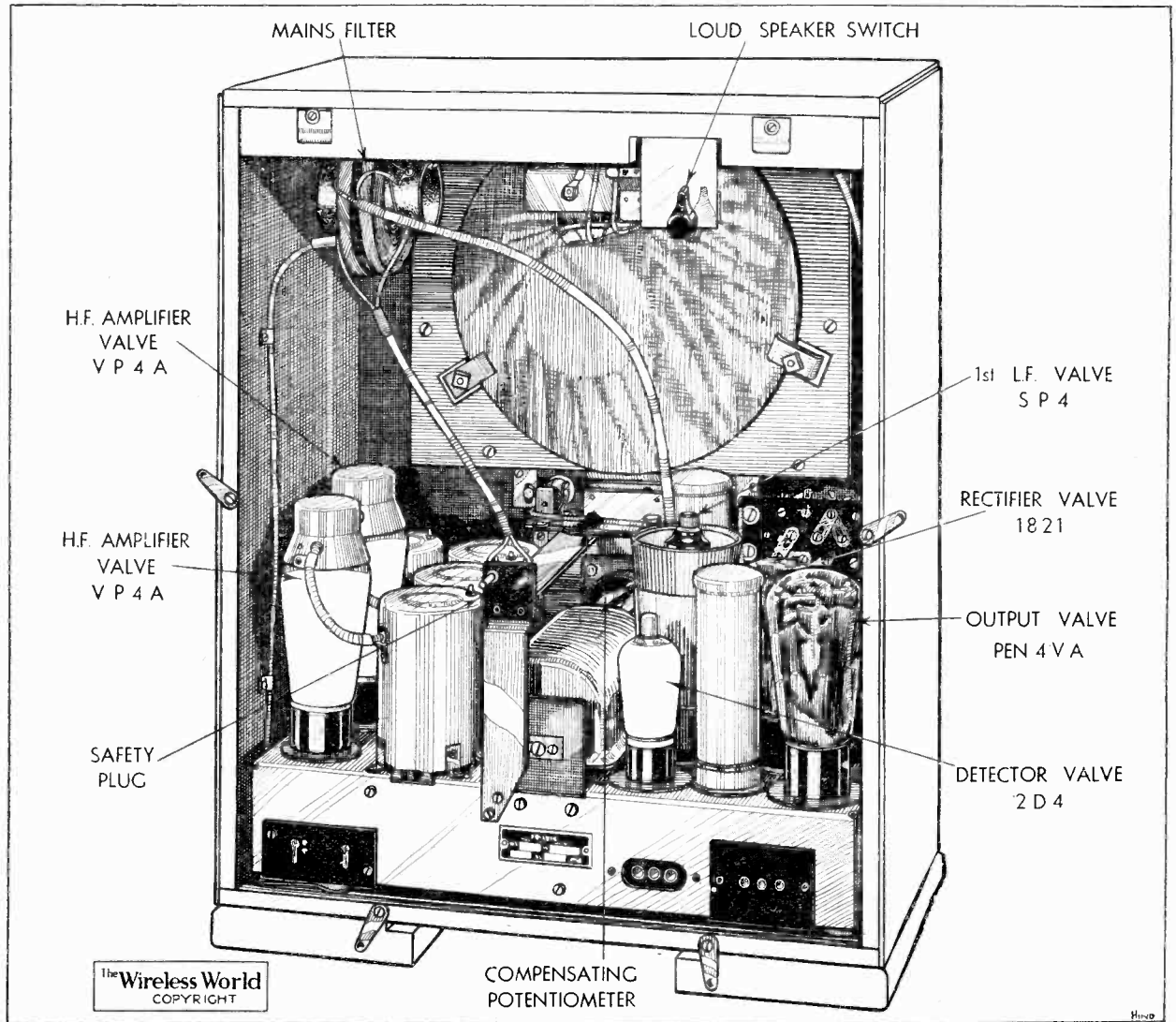

General view of the back of the Type 472A receiver. Note the mains filter coils.

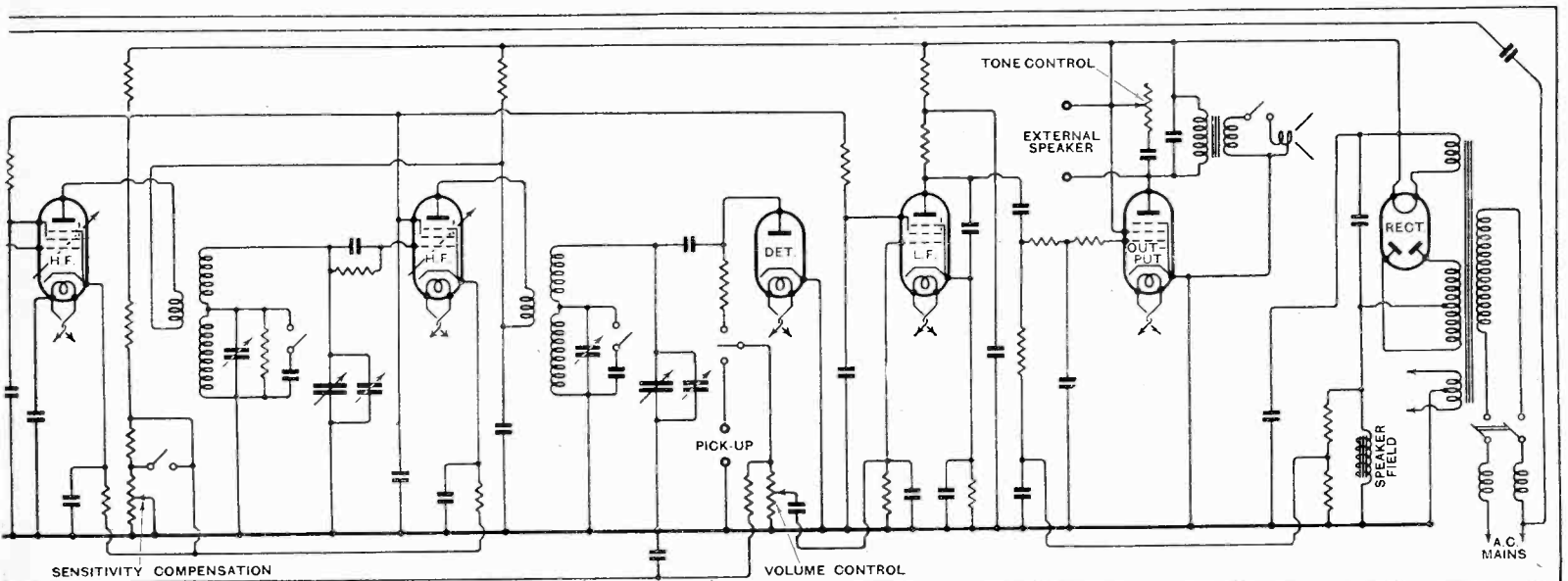

operates in the first H.F. stage, and the initial bias of both H.F. valves is varied with the tuning to give uniform amplification over the wave-range.

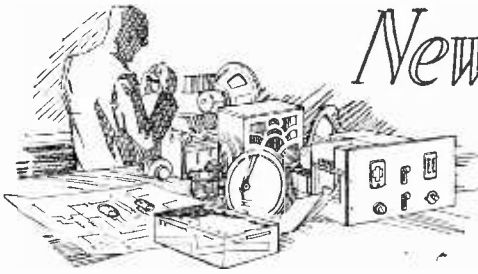

BLUE SPOT "STAR JUNIOR" LOUD SPEAKER

DESIGNED on the same lines as the Blue Spot "Star" unit already reviewed in the pages of this journal, this model is fitted with a simplified magnet system which, while it does not give quite the same electro-acoustic efficiency of the larger model, is nevertheless comparable in performance with cobalt or chrome steel magnets of much larger size. The diaphragm is provided with a spherical cap for the apex of the cone, but the back of the air gap is open.

On test we found that the quality is notable for the good reproduction in the upper register, and while the body of tone is not, perhaps, so full as in the larger models in the range, the fundamental resonance at 100 cycles is sufficient to provide adequate simulation of bass response. The high-frequency output reaches a maximum in the region of 4,500 cycles, and there is a fairly well defined cut-off at 5,000 cycles. The customary resonance at about 2,500 cycles was entirely absent.

The unit is supplied with a universal transformer mounted in the base of the die-cast aluminium frame, and sockets are included which enable the unit to be used as an extension loud speaker.

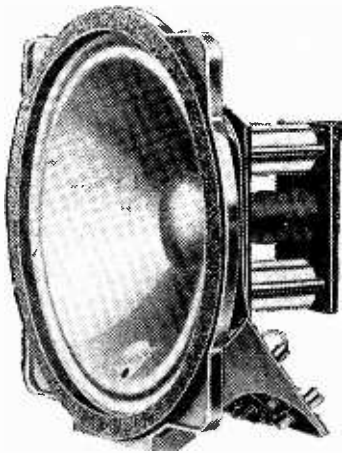

The Blue Spot "Star Junior" permanent magnet loud speaker.

The price of the chassis is 35s., and a cabinet model is available at 48s. 6d. The makers are the British Blue Spot Co., Ltd., 94/96, Rosoman Street, Rosebery Avenue, London, E.C.1.

BELLING-LEE DISTURBANCE SUPPRESSOR, No. 1171

THIS model has been designed primarily for use with small commutator motors the frames of which are not truly earthed. The unit contains three high-voltage test condensers arranged in such a way that although the electrical disturbances are confined to the motor using its frame as the "earthing" point the mains are completely isolated from all exposed metal parts.

New Radio Products Reviewed

Recent Products of the Manufacturers

A metal case is employed, and the unit should be screwed securely to the frame so that a good electrical contact is made, and two short rubber-covered leads connected to the brushes on the machine. It can be used in D.C. circuits up to 450 volts, and in A.C. circuits up to 250 volts. A Belling-

and tested at 2,500 volts. This would be suitable for connecting between the anodes of a full-wave rectifying valve and its filament, an arrangement of condensers which will often remove the last trace of modulation hum when additional smoothing and the usual precautions fail to eliminate it entirely. This model, described as the "BUF," costs 2s. 6d.

A special condenser of 4+4 mfd. for Cathode Ray Tube mains equipment and for 1,500 volts D.C. working is included in the range, and its price is 36s.

Tests have been made with several specimens of these new condensers, and they have been found entirely satisfactory.

MUIRHEAD DECADE RESISTANCE UNITS

THESE units are essentially for laboratory use, and, consequently, it goes without saying that the accuracy of adjustment and the workmanship are both of a very high order.

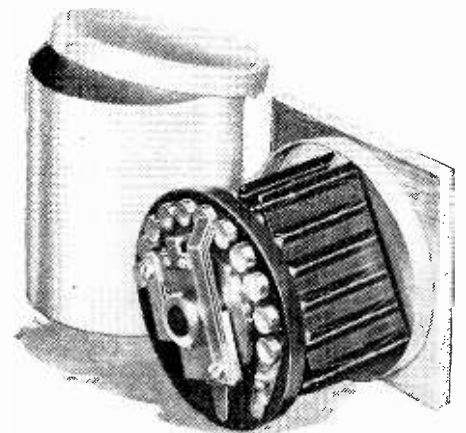

Muirhead type 5 decade resistance unit wound in steps of 100 ohms.

The type 5, as illustrated, is available in nine different models, six of which are decade resistances, while the remaining three are arranged as ratio units for bridge work. Each unit is fitted with laminated brush-type switches with the switch arm insulated from the panel by a removable Bakelite spindle, which construction facilitates the gauging of two or more units. Incidentally they can be wound to give any desired combination of resistances for special requirements or to form a "T" network attenuator arranged in decibel steps.

The standard decade resistance units are made in 0.1-ohm, 1-ohm, 10-ohm, 100-ohm and 1,000-ohm steps, and the accuracy of adjustment on D.C. is 0.5 per cent. for the 0.1-ohm step unit and 0.1 per cent. for the other units, and this takes into account the switch contact resistance. There are eleven contacts on the switch, and a self-locating mechanism is embodied for each stud position.

These unit boxes are especially suitable for use in all types of test apparatus requiring precision resistances and for the construction of measuring bridges, and prices range from £2 12s. 6d. for the 0.1-ohm step box to £3 17s. 6d. for the 1,000-ohm step unit, and the makers are Muirhead & Co., Ltd., Elmers End, Beckenham, Kent.

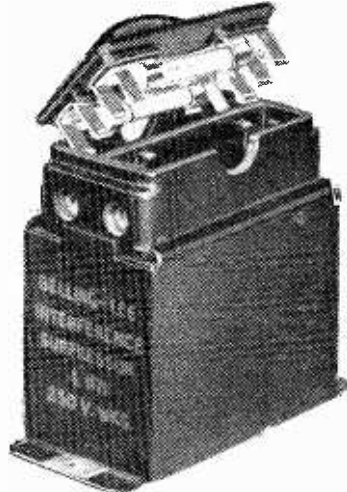

Belling-Lee interference suppressor for small unearched motors.

Lee twin fuse holder is fitted, and the price is 8s. 6d. The makers are Belling and Lee, Ltd., Cambridge Arterial Road, Enfield, Middlesex.

SOUND SALES CONDENSERS

SOUND SALES, Ltd., Tremlett Grove, Highgate, London, N.19, has introduced a new range of paper dielectric smoothing condensers. There are four principal types ranging from 350-volt D.C. working condensers to models suitable for use in 800-volt D.C. circuits. All are assembled in metal cases fitted with a top cover of insulating material carrying terminals and soldering tags, but, with the exception of the type C, which are the 800-volt models, these have all-metal containers with porcelain insulators on the top supporting the terminals. In this type 2- and 4-mfd. sizes only are available, and they cost 8s. and 15s. each respectively. The test voltage is 2,000 D.C.

Type D contains two models—one a double condenser of 4+4 mfd., and one of 8 mfd.; they are 350-volt D.C. working

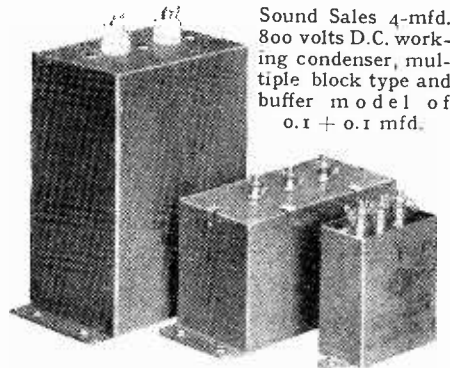

Sound Sales 4-mfd. 800 volts D.C. working condenser, multiple block type and buffer model of 0.1 + 0.1 mfd.

models, tested at 750 volts, and the prices are 12s. 6d. and 12s. each respectively.

There is also a buffer condenser of 0.1+0.1 mfd. for 1,000-volt D.C. circuits,

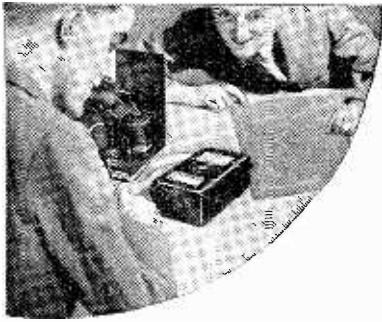

"Good...that's found the fault...
what a good thing I bought myself a
PIFCO ROTAMETER"

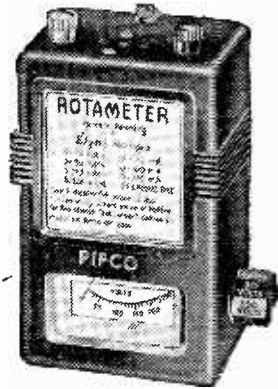

A whole night's job becomes but a few minutes work with the Pifco ROTAMETER. For quick tracing of troubles there is nothing like it. It tests and checks everything, even itself; any one of eight dials being brought into view by turning the octagonal knob at the side of the instrument. Convenient in size and of amazing accuracy, over 100 tests are possible with this mains or battery radio testing instrument.

ROTAMETER

9 SEPARATE METERS IN ONE.

- 1.—0-8 volts. For low tension voltage test.
- 2.—0-30 volts. For grid-bias voltage test.
- 3.—0-250 volts. For high-tension voltage test.
- 4.—BATTERY TEST.
- 5.—0-20 M.A. For individual valve test.
- 6.—0-100M.A. For testing current taken by total valves in set.
- 7.—0-250M.A.
- 8.—FILAMENT AND RESISTANCE TEST (4,000 ohms.) For D.C. and Rectified A.C.
- 9.—Plug-in test for valves.

Ask your dealer to show you one now or write for fuller details to PIFCO LTD., SHUDEHILL, MANCHESTER, and 150, Charing Cross Road, London, W.C.2.

Size of each dial 1 3/4" x 1 1/4". Finished in black bakelite and supplied complete with leads in velvet-lined case. Price **29/6**

PIFCO ROTAMETERS

PIFCO ON THE SPOT WILL TRACE YOUR TROUBLES LIKE A SHOT

WIRELESS

DIRECTION FINDING

and **DIRECTIONAL RECEPTION**

(1927)

By **R. KEEN, B.Eng. (Hons.)**

Second Edition

THIS volume deals with the principles of the subject and the constructional details of direction-finding installations, and includes some information concerning aircraft equipment. It describes the principles of Direction and Position Finding in such a way that the subject may be grasped easily by engineers tackling this field of wireless work for the first time. Numerous photographs and diagrams are included.

Price **21/- net.** By post **21/9**

From leading booksellers or direct from the Publishers:

ILIFFE & SONS LIMITED

Dorset House, Stamford Street, London, S.E.1
 w.w.68

AMPLION

"RADIOLUX" SUPER-HET RECEIVERS - RADIOGRAMS

The spontaneous success of "Amplion" Super-hets at "Radiolympia" has made it necessary for an immediate increase of output, and readers of The "Wireless World" benefit by this because it has enabled us to give greater radio value than ever. Amplion offer the finest "Super-het" value in radio entertainment that it is possible to secure. The name Amplion is your guarantee of quality, performance and craftsmanship.

"RADIOLUX" SUPER-HET

5-Valve including rectifier. For A.C. Mains 190/265 or 110 volts, 40/100 Cycles.

AUTOMATIC VOLUME CONTROL
 NEON LIGHT VISUAL TUNING.
 FULL VISION SCALE illuminated, and calibrated in metres and degrees. ENERGISED MOVING COIL SPEAKER GRAMOPHONE PICK-UP AND EXTERNAL SPEAKER CONNECTIONS.

TWO-TONE WALNUT CABINET with Gold Silk grille with ebonite black surround panel.

H.P. Terms: £1.6.6
 Deposit and 12 payments of £1.1.0 **12 GNS.**

Also D.C. Model 190/265 v.

H.P. Terms: £1.8.0
 Deposit and 12 payments of £1.2.9 **13 GNS.**

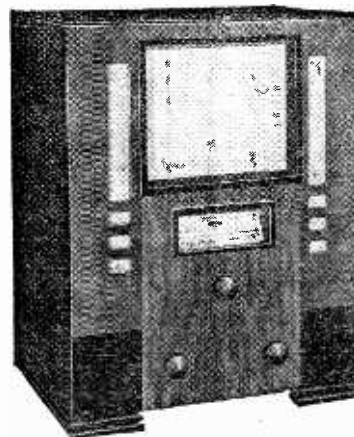

19" High. 15" Wide. 12" Deep.

"RADIOLUX" SUPER-HET RADIOGRAM

A very remarkable instrument with all the outstanding features of the "Radiolux" Super-het Receiver mentioned above.

Collaro gramophone motor is electrically operated. Fitted with full automatic stop. Pick-up is the well-known Amplion unit.

Beautiful cabinet veneered in two-tone walnut with burr walnut control panel.

H.P. Terms: £2.17.9
 Deposit and 12 payments of £1.15.0 **21 GNS.**

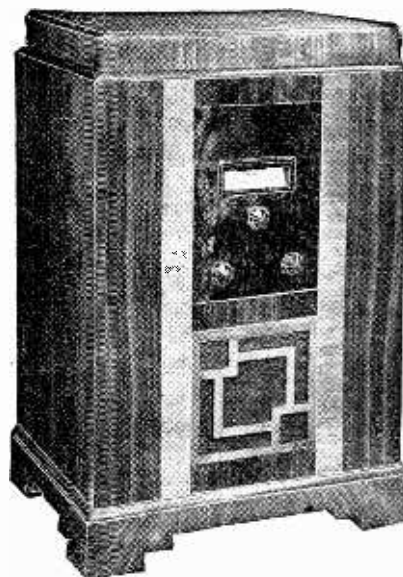

36" High. 23" Wide. 19" Deep.

In addition to the above there is the Amplion "Radiolux" Auto-gram; a luxury super-het fitted with the latest British Capehart automatic record changer. Price **50 Gns.** H.P. Terms available.

SEND FOR ILLUSTRATED LITERATURE OF ALL AMPLION PRODUCTS

AMPLION (1932) LTD.

82-84, Rosoman Street, Rosebery Avenue, London, E.C.1
 Telephone: Clerkenwell 5440-5441

Mention of "The Wireless World," when writing to advertisers, will ensure prompt attention.

MISCELLANEOUS ADVERTISEMENTS

NOTICES.

THE CHARGE FOR ADVERTISEMENTS in these columns is

12 words or less 3/- and 3d. for every additional word.

Each paragraph is charged separately and name and address must be counted.

SERIES DISCOUNTS are allowed to Trade Advertisers as follows on orders for consecutive inscriptions, provided a contract is placed in advance, and in the absence of fresh instructions the entire "copy" is repeated from the previous issue: 13 consecutive insertions 5%; 26 consecutive, 10%; 52 consecutive, 15%.

ADVERTISEMENTS for these columns are accepted up to **FIRST POST ON MONDAY MORNING** (previous to date of issue) at the Head Offices of "The Wireless World," Dorset House, Stamford Street, London, S.E.1, or on **SATURDAY MORNING** at the Branch Offices, 19, Hertford Street, Coventry; Guildhall Buildings, Navigation Street, Birmingham, 2; 260, Deansgate, Manchester, 3; 28a, Renfield Street, Glasgow, C.2.

Advertisements that arrive too late for a particular issue will automatically be inserted in the following issue unless accompanied by instructions to the contrary. All advertisements in this section must be strictly prepaid.

The proprietors retain the right to refuse or withdraw advertisements at their discretion.

Postal Orders and Cheques sent in payment for advertisements should be made payable to **ILIFFE & SONS Ltd.**, and crossed **& Co.** Notes being untraceable if lost in transit should not be sent as remittances.

All letters relating to advertisements should quote the number which is printed at the end of each advertisement and the date of the issue in which it appeared.

The proprietors are not responsible for clerical or printers' errors, although every care is taken to avoid mistakes.

NUMBERED ADDRESSES.

For the convenience of private advertisers, letters may be addressed to numbers at "The Wireless World" Office. When this is desired, the sum of 6d. to defray the cost of registration and to cover postage on replies must be added to the advertisement charge, which must include the words Box 000, c/o "The Wireless World." All replies should be addressed to the Box number shown in the advertisement, c/o "The Wireless World," Dorset House, Stamford Street, London, S.E.1. Readers who reply to Box 110, advertisements are warned against sending remittance through the post except in registered envelopes; in all such cases the use of the Deposit System is recommended, and the envelope should be clearly marked "Deposit Department."

DEPOSIT SYSTEM.

Readers who hesitate to send money to advertisers in these columns may deal in perfect safety by availing themselves of our Deposit System. If the money be deposited with "The Wireless World," both parties are advised of its receipt.

The time allowed for decision is three days, counting from receipt of goods, after which period, if buyer decides not to retain goods, they must be returned to sender. If a sale is effected, buyer instructs us to remit amount to seller, but if not, seller instructs us to return amount to depositor. Carriage is paid by the buyer, but in the event of no sale, and subject to there being no different arrangement between buyer and seller, each pays carriage one way. The seller takes the risk of loss or damage in transit, for which we take no responsibility. For all transactions up to £10, a deposit fee of 1/- is charged; on transactions over £10 and under £50, the fee is 2/6; over £50, 5/-. All deposit matters are dealt with at Dorset House, Stamford Street, London, S.E.1, and cheques and money orders should be made payable to Iliffe & Sons Limited.

SPECIAL NOTE.—Readers who reply to advertisements and receive no answer to their enquiries are requested to regard the silence as an indication that the goods advertised have already been disposed of. Advertisers often receive so many enquiries that it is quite impossible to reply to each one by post. When sending remittances direct to an advertiser, stamp for return should also be included for use in the event of the application proving unsuccessful.

THE LAST WORD IN RADIO



Universal SUPERHET SEVEN

The set that works on any mains, any voltage, any wave band, truly Universal. Receives all important stations in the world from 13 to 2,000 metres. Employs delayed A.V.C., fluid-light tuning indicator, and all the other latest refinements in Radio design.

Universal SUPERHET FIVE

For any mains, any voltage, any wave band. Covers a range from 19 to 2,000 metres. Reception obtainable from any part of the world, to any part of the world. The sets with easy control for perfect quality.

Special Features:—Greater output. Most economical in cost. No barretters, resistances, mains transformers. Completely hum-free. Mains insulated.

Write for details to:—**UNIVERSAL HIGH VOLTAGE RADIO LTD.**
28-29 Southampton St., London, W.C.2. **TEMPLE** Ear 4935.

THE WORLD'S

HANDIEST AERIAL



and it gives a maximum pick up, with less interference. Adheres anywhere—just press it and it sticks.

NO UNSIGHTLY WIRES—that is why Pix Invisible Aerial is in use in so many modern homes.

PIX INVISIBLE AERIAL

2/- Double length 3/6

CABINETS
65/- Radio-gram Cabinet for 35/-
NO MIDDLE PROFITS.
Finest Radio Furniture as supplied to B.B.C.

PICKETT'S
Cabinet (W.W.) Works, Boxleyheath, Near London.

LIST FREE

YOU CANNOT BUY A BAKER SPEAKER WITHOUT BUYING QUALITY

● **SUPER-POWER.**
The Music Lovers' choice for 10 years

FYDELITONE
The Ideal Extension Speaker

BAKER'S
SELHURST RADIO LTD.
75 & 77, SUSSEX ROAD, CROYDON, SURREY.
PHONE: CROYDON 3441/2

SPEEDY SERVICE - NO SUBSTITUTES

EVERY RADIO REQUIREMENT VALVES - SPEAKERS - SETS - COMPONENTS, etc.

Order your needs to-day from the postal service specialists: all goods are brand new and guaranteed and are delivered immediately carriage paid at list prices for cash with order or C.O.D. (Pay the postman)

INTERNATIONAL RADIO BUREAU 199, DEANSGATE MANCHESTER.

ENGINEERS-IMPORTANT OFFER

As the leading Institute of its kind in the World, we offer to prepare you at home for the **A.M.I.Mech.E., A.M.I.E.E., A.M.I.A.E.**, or similar qualification, on the distinct understanding that if you fail your Examination your tuition fee will be returned to you in full. Realise what a difference a few letters after your name will mean to you, and you will realise the value of our extraordinary offer to prepare you on "NO PASS—NO FEE" terms. Our record in the above Examinations is over 95% successes. Whatever your age or experience you should apply immediately for a copy of our hand-book "ENGINEERING OPPORTUNITIES," giving details of all leading Engineering Examinations, and over 100 Courses in all branches of **Civil, Mech., Elec., Motor, Radio and Aero Engineering.**

This book is sent free and without obligation.

BRITISH INSTITUTE OF ENGINEERING TECHNOLOGY,
387, SHAKESPEARE HOUSE,
29/31, OXFORD STREET, LONDON.

Receivers and Amplifiers, Etc.—Contd.

IGRANIC Amplifier, 5 stage A.C. mains, 6 watts undistorted, metres, separate power unit, 3 rectifying valves, in metal cases with stand, cost over £100, bargain at £110.—Gregory, Chelidar. [6496]

1935 Models, 4 valve superhet A.C. or D.C. M.C. speakers, £3/19/6; 5 valve £5/5, car radio £8/10 including valves, approx. *Wireless World*, deposit.—Lovell Bros., 11, Avon Rd., London, E.17. [6533]

PUBLIC Address Amplifiers.—A.C. mains, three stage, 21 watts, undistorted A.C. output, complete with valves, £15; universal A.C./D.C. three stage, 7 watts output, complete, £13; guaranteed 12 months; trade supplied; deferred terms.—D. E. Clarkson, B.Sc. (Eng.), 7a, Bridge Rd., Wallington, Surrey. 'Phone: Wallington 3953. [6280]

ARMSTRONG.—Latest 5v. bandpass superheterodyne chassis, with fully delayed A.V.C., 7 highly efficient tuned circuits, bandpass input, Marconi Hexode frequency changer, combined 1st detector and oscillator, bandpass I.F., coupled to Marconi H.P.; pentode, bandpass coupled to Cossor Double Diode, giving distortionless detection and A.V.C., resistance coupled to Mazda high slope pentode, Marconi bi-phase rectifier, full vision illuminated tuning, calibrated in wavelengths, combined radio and gramophone volume control, corrected pentode output, giving exceptionally good reproduction; £5/18/6, with valves, Royalties paid.

ARMSTRONG.—Universal bandpass superheterodyne chassis, fully delayed A.V.C., specification as A.C. model above; £6 18/6; with Mazda valves, Royalties paid.

ARMSTRONG Latest 4v. 3 pentode A.C. Chassis, further improved, practically superheterodyne performance, silent background, incorporates full bandpass, 3 tuned circuits, illuminated horizontal drive, calibrated wavelengths, combined radio gramophone switching, 3 watts output; £5 18 6, with valves.

ALL Armstrong Chassis are Constructed of the Highest Grade Components Throughout, carry 12 months' service free guarantee, and are sent on 7 days' approval, carriage paid.

ARMSTRONG MANUFACTURING Co., 100, King's Rd., N.W.1. [6445]

ORDINARY and Midget Receivers, all brand new, complete with valves, moving coil speaker, working off A.C. and D.C. mains, 100-130 or 200-250 volts, Belmont 4-valve 250-500 metres, in handsome walnut cabinet, 10x7x5½, at £3/10; as above, but 250-500 and 1,000-2,000 metres, cabinet with chromium fittings, at £4/6 3; Emerson 5-valve, L. and M. wave, pick-up terminals, walnut cabinet, at £4/10; Victor (H.M.V. in U.S.A.) 5-valve superhet, gets over 70 stations, walnut cabinet (11½x7½x8½), incorporating every gadget (1935), A.V.C. illuminated dials, tone control, large M.C. speaker, operate on battery as well as mains, adaptor and leads included, listed £15/15, at £6/5; Midget radiogram chassis (Kadette), 9x4½x6½, complete, ready for mounting in own gramophone or portable cabinet, L. and M. wave bands, ordinary receivers, 200-250, A.C. only (why be confined to European stations), Victor (H.M.V. in America) 5-valve superhet all-wave, 15-50, 70-200, 250-550 metres, with large speaker, clock tuning, walnut cabinet, 10½x14x8, listed £21, at £8/10; another, covering 250-500 and 1,000-2,000 metres only, cabinet 13x10x8, listed at £16/16, at £5/5; all carriage paid.—Degallier's, 4, Coryton House, 21, Upper Marylebone St., London, W.1. Museum 7795. [6509]

Set Manufacturers' Surplus, Clearance and Bankrupt Stocks offered in any of these columns may not be Manufacturers' current lines. Radio components advertised at below the list price do not carry any manufacturer's guarantee.

RECEIVERS AND AMPLIFIERS, ETC.

BARGAINS in Used Radiograms.

R.G.D. Type 901 8-valve Superheterodyne, for D.C. mains, listed at 80 guineas, £25; McMichael 3-valve, A.C. mains, £12/10; Hart-Collins Passport 4, D.C. and A.C. models, £6 each; also following receivers: Ultra Tiger Superhet, A.C. mains, £7; McMichael Twin-Speaker Supervoxt, A.C., £10.

ALL Guaranteed First Class Condition, in most cases have been used for shop demonstration only.

WEBBS, 14, Soho St., W.1 (few yards from Oxford St., near Tottenham Court Rd. Tube Station). [6477]

7-Valve Century Car Radio, as new complete with valves; £7/7.—58 Flat, Mantell St., N.1. [6499]

SINGLE-SPAN Receiver Portion, with A.C. valves, £7.—Wickham, 40, Grosvenor, Bath. [6469]

COLUMBIA 1934 Battery Radiogram, new condition; £10/10; Spencer superhet. portable, perfect, £5/10.—50a, Widmore Rd., Bromley. [6472]

CROSLEY and Emmerson's Midgets and Car Radio; send for wholesale catalogue, importer, Royal, 5, Buckingham Rd., London, E.18. [6447]

EKCO, 1935 R.G.23, A.C. Radiogram, list £29/8, show-room model in guaranteed perfect order; £10/10.—Reider, 49, Coborn Rd., London, E.3. [6501]

OUR Kit of Parts for "Wireless World" Quality Amplifier, complete in every detail, including valves; amplifier only, £8/10; feeder unit, 36/-. [6501]

OUR Kit of Parts for "Wireless World" Olympic S.S. Six, complete in every detail, including valves and loud-speaker; £14/10.

SEND for Detailed List of Components for Either of the Above Kits; carriage paid, cash with order.

WARD, 45, Farringdon St., London, E.C.4. 'Phone: Holborn 9703. [6402]

SINGLE-SPAN Receiver, complete, exception power and rectifier portion, perfect working order; £5, or nearest offer.—Whipp, Killaloe, Westward Ho! [6471]

JOHNSON and **PHILLIPS** 120-watt "Double Channel" A.C. Amplifiers, 200-250 volts, in metal cabinet, complete with valves, in new condition throughout; cost £150, bargain, £35 each.

AMPLION 25-watt A.C. Output Amplifiers, 110-250 volts, Westinghouse metal rectifier incorporated for H.T., last few; breaking up price, £3.

MARCONI P.A. Amplifier, D.A.60, in output stage, suitable to run off converter, less valves; £5.

MARCONI 60-watt A.C. Amplifiers, type P13, 110-250 volts, suitable for microphone, gramophone, or radio, in polished oak cabinets, complete with valves; £10/10 each.

FURTHER Particulars of Various P.A. Gear, send stamp for lists; callers invited.—H. Franks, 23, Perc. St., Tottenham Court Rd., W.1. Museum 8585. [6504]

Receivers and Amplifiers, Etc.—Contd.

37/6—S.G.3 2-gang Polar, Ormond loudspeaker, in walnut cabinet, listed 8 guineas, without valves and batteries, c.o.d. or cash with order, carriage forward.—Kay, 167, City Road, London, E.C.1. [6489]

A PUBLIC Address Equipment, manufactured by Marconi Special Products; 1 3-stage amplifier with a D.A.60 output, 1 rotary converter, 1 twin turntable unit, 2 Marconi 2in. public address speakers and batteries, guaranteed perfect; cost £170, for quick sale, £65.—Box 1551, c/o *The Wireless World*. [6466]

MAINS EQUIPMENT.

VORTEXION.

VORTEXION Specified Olympic S.S. 6 Transformer, S.S.352, 5 years' guarantee, 25/-; less terminals and guarantee, 21/-; power chassis, £3/17/6; choke, 12/6; single span model, 25/-; power chassis, £3/10.

VORTEXION—Quality amplifier or super monodial, 425-0-425, 120 m.a., 4v. 6-8a, C.T., 4v. 3a, C.T., 4v. 1a, 4v. 1a, super shrouded, core size 2 1/4 in. x 1 1/4 in., 2 1/2% regulation primary engraved insulated terminals, weight 14lb., 26/-; carriage 2/-; normal shrouded, 22/-; open type, 20/-; post 1/3; speaker field replacement choke, 16/-; special output transformer, to "W.W." spec., 12/6.

VORTEXION—A.C. short wave receiver, 350-0-350, 60 m.a., 4v. 5a., 4v. 2a., screened primary; 16/-; post 9d.

VORTEXION 7.30h. 120 m.a. Choke, 215 ohms, in die cast shrouding to match; 12/6

IMITATED, but unequalled. Good enough for a "Wireless World" specification is good enough for you.

VORTEXION Cost Little More than the Cheapest, but unexcelled by the dearest.

VORTEXION Standards Despatched by Return.

VORTEXION A.C./34, used by author in construction of A.V.C. Three, as illustrated, 18/-.

GUARANTEED 12 Months, and within 5% normal and 2 1/2% super models, neat shrouding, with detachable feet, as used by Government Departments, etc., etc., any model guaranteed 5 years at extra cost of 2/-.

ALL Secondaries Centre Tapped.

VORTEXION—250-0-250 60 m.a., 4v. 1 to 2a., 4v. 2 to 4a., open type, 10/-; shrouded, 12/6; post 9d.

VORTEXION—Ferrocort III, 350-0-350, 60 m.a., 4v. 2.5 C.T., 4v. 3.5 C.T.; open type 13/6, shrouded 16/-; post 9d.

VORTEXION—Super model for H.T.8 or 9 or 10, 4v. 1 to 2, 4v. 2 to 4, open type 14/6, shrouded 16/6; post 1/-.

VORTEXION—350-0-350, 120 m.a., 4v. 2 to 5a., 4v. 2 to 4a., 4v. 2.5a.; open type 14/6, shrouded 16/6; super shrouded model, weight 11lb., 4 filaments to specification, 21/-; post 1/3.

VORTEXION—400 or 450 or 500v. 120 m.a., 4v. 2 to 5, 4v. 2 to 5, 4v. 2.5a.; open type 19/-, shrouded 23/-.

VORTEXION—400 or 450 or 500, 150 m.a., 4v. 4a., 4v. 2.5, 4v. 2, 4v. 2, 4v. 2, core size 2 1/4 x 1 1/4 in., a super job, 2% regulation, 35/-; shrouded, with terminals; less terminals, 30/-; open type, 26/-; post 1/3.

VORTEXION Auto Transformers to B.E.S.A. Specification, 100, 110, or 120v. to 200, 220, or 240 volts, 60 watts, 9/-; post 9d.; 120 watts, shrouded 12/6, open type 10/6, post 1/-; 200 watts, shrouded 16/6, post 1/-; 2,000 watts, £4/10.

VORTEXION 1,000-watt Transformers; £4/10, carriage fee.

VORTEXION 30h. at 50 m.a. Chokes, 5/6; 40h. at 60 m.a., £5/3; 30h. at 150 m.a., 200 ohms, 10/6 open type, 12/6 shrouded.

VORTEXION Transformers Made to Your Specification; price according to wattage, 6v. filaments same price unless wattage grossly exceeded; special quotations by return.

VORTEXION (S. A. BROWN), 192, The Broadway, Wimbledon, S.W.19. Tel.: Liberty 2814. [6360]

BATTERY Chargers.—The N.P. for quality, service and reliability at low cost.

BATTERY Chargers.—New and showroom soiled models from 25/- to £17; list.

BATTERY Chargers.—Trade lists free, state your requirements.—N. P. Electrical Co., 514, Alum Rock, Birmingham, 8. [6521]

TANTALUM for A.C. Chargers, H.T. and L.T.—Blackwell's Metallurgical Works, Ltd., Garston, Liverpool. [6470]

PARAMOUNT Mains Transformers, equal to any, and better than most; try them once and you will always use them!

PARAMOUNT Auto Transformers, 100-120v. up to 200-250 volts, or vice versa, 60 watt, 8/6; 120 watt, 10/-; shrouded 2/- extra, post 9d.

PARAMOUNT—250-0-250v. 60 m.a., 4v. 1 to 2 amp., 4v. 2 to 4a., open type, 9/6; shrouded, 11/6; post 9d.

PARAMOUNT—350-0-350v. 60 m.a., 4v. 2.5a., 4v. 3 to 5a., 13/-; shrouded, 15/-; post 9d.; 120 m.a., 4v. 5 amp., 4v. 4 amp., 4v. 2.5a., with screened primary, shrouded, 16/-; post 1/-.

PARAMOUNT—Single span model, with 1 1/2 in. x 1 1/2 in. core size, 350-0-350v. 100 m.a., 4v. 5a., 4v. 1a., 4v. 2.5a., shrouded, with screened primary, 2 1/2% regulation, 20/-.

PARAMOUNT—500v. or 450v. or 400v. 120 m.a., 4v. 1 5a., 4v. 4a., 4v. 2.5a., screened primary, 18/-; shrouded, 21/-; post 1/3; 150 m.a., 4v. 2.5a., 4v. 4a., three 4v. 2a., with 2 1/4 in. x 1 1/4 in. core size, shrouded, 28/-; post 1/3.

PARAMOUNT—Westinghouse transformers, H.T.8, 9 or 10, with 4v. 2a., 4v. 4a., shrouded, 16/-; post 1/-.

PARAMOUNT. Chokes, 30h. 60 m.a., 5/6; 20h. 120 m.a., 8/6, post 9d.

PARAMOUNT Mains Transformers are Guaranteed for 12 Months.

PARAMOUNT Products are Fitted with Neat Aluminium Frames or Shrouds, all filaments C.T., insulating paper 2 1/2 mils thick between each layer, and tested thoroughly before leaving our works.

PARAMOUNT Transformers Made to Your Own Specifications; price according to wattage; quotations by return.

PARAMOUNT Guaranteed Electrolytic Condensers, 4+4 mfd., 500v. peak, 3/6, post 3d.

PARAMOUNT Mains Transformers, manufactured by Brock and Salter, 66, Hartfield Rd., Wimbledon, S.W.19 (one minute from Wimbledon Station). Tel.: Liberty 3226. [6315]

FIRST-CLASS MAINS TRANSFORMERS

HEAYBERD
MONARCH OF THE MAINS

HEAYBERD have specialised in Transformers for over a decade and manufacture a model for every purpose. Heayberd Transformers are noted for their Quality, Efficiency and RELIABILITY. Below are models for use with Westinghouse H.T. Rectifiers.

W. 31.
Designed for use with H.T.8 Rectifier. Rectified Outputs 200 or 250v. 60 ma. 4v. 5 amps. and 4v. 1 amp for A.C. Valves.....**Price 29/-**

W. 34.
For use with H.T.10 Rectifier. Rectified Output 200v. 100 ma. 4v. 5 amps. and 4v. 1 amp. for A.C. Valves.....**Price 34/-**

W. 40.
For use with H.T.12 Rectifier. Suitable for Battery Eliminators. Rectified Output 175v. 25 ma., or 200v. 30 ma.....**Price 14/-**



F. C. HEAYBERD & CO.,
10, Finsbury St., London, E.C.2.

.....
Cut out this advert, write your name in the margin, and send NOW enclosing 3d stamps for NEW 1935 Radio Handbook describing these Transformers and giving blue-prints and circuit diagrams of Mains Units
.....

New CLIX AERIAL EARTH MASTER PLUG

TAKES ANY WIRE



UPTO 3/16" OVERALL

With this new Clix "A.E." Master Plug—the only really universal plug—you can carry the heavy lead-in wires straight to your set, without breaks or joins. This Clix plug takes any wire up to three-sixteenths inch overall, and the Clix method of wiring ensures perfect contact.

IT IS WORTH YOUR WHILE TO SEND A POST-CARD FOR A COPY OF OUR NEW TWO-COLOUR ILLUSTRATED FOLDER "F."

LECTRO LINX LTD.
79a Rochester Row, London, S.W.1

Mains Equipment.—Contd.

HOYNE'S Transformers are Manufactured by Engineers with 14 Years' Experience in Radio Transformer Design.

HOYNE'S Transformers, fitted with tapped and screened primaries, filaments, all centre tapped, stout cast aluminium clamps and clearly marked terminal strips are fitted to all models, write for list.

HOYNE'S Components are Guaranteed for One Year; one type only manufactured, the best, as used by many well-known set manufacturers after testing all others.

HOYNE'S—"W.W." transformers wound strictly to specification of author: "W.W." test reports, June 22nd: "The insulation is particularly good throughout... the transformer is satisfactory in all respects."

HOYNE'S—Push-pull quality amplifier transformer, 25/-, post 1/3; 7/30 henrys choke, 9/6, post 9d.; 20 henrys, 7/6, post 9d.

HOYNE'S—Single span, 15/-, post 1/-; choke, 10 henrys, 7/6, post 9d.

HOYNE'S—Everyman A.C. super transformer, 12/6, post 1/-; choke, 10 henrys, 7/6, post 9d.

HOYNE'S—A.V.C. Straight Four transformer, 18/-, post 1/3; choke, 26 henrys, 12 m.a., 140 ohms, 9/6, post 9d.

HOYNE'S—Push-pull quality amplifier, complete to "W.W." specifications, wired and fully tested, less valves, £5/12/6; complete kit of components including metal chassis, £5/2/6; field replacement choke, 1.250 ohms, 13/6, post 1/-; output transformer, 12/6, post 1/-.

HOYNE'S—250-0-250v. 60 m.a., 4v. 1 to 2a., 4v. 2 to 4a., 10/-, post 9d.; with extra 4v. 1 to 2a. winding, 12/6, post 1/-.

HOYNE'S—Ferrocort III, 350-0-350v., 60-70 m.a., 4v. 2 to 3a., 4v. 2 to 4a., 12/6, post 1/-; with extra 4v. 1 to 2a. winding, 13/6, post 1/-.

HOYNE'S—350-0-350v., 120 m.a., 4v. 2 to 3a., 4v. 4 to 6a., 4v. 1a., 4v. 1a., 18/-, post 1/3.

HOYNE'S—400 or 450 or 500v. 120 m.a., 4v. 2 to 3a., 4v. 2 to 5a., 4v. 1 to 2a., 18/-, post 1/3.

HOYNE'S—500-450-0-450-500v. 140 m.a., 4v. 2 to 4a., 4v. 4 to 6a., 4v. 2a., 4v. 2a., 27/6, post 1/3; weight 11lb.

HOYNE'S Transformers, built to specifications, keenest prices, best materials and workmanship; quotation by return.

M. J. HOYNE, ALL-POWER TRANSFORMER, Ltd., Offices and Works, 8a, Gladstone Rd., Wimbledon, S.W.19. Tel.: Liberty 3303. [6488]

CABINETS.

MANUFACTURERS' Clearance.

ULTRA "Panther," a modern cabinet, with contrasting figured walnut veneer panels, 20x17x11, 13/6; pedestal type, 35x22x12, 30/-, undrilled; photo sent on request.

SET and Speaker Cabinets; 5/- upwards.

RADIOGRAM Cabinet; 37/6 upwards.

SPEAKER Cabinets; 4/6 upwards.

SEND Particulars of Your Requirements (giving size of set, etc.), or call and make your choice from our stocks of over 100 different types; from 3 6 to £4/10.

REFER to Previous Advs. for Detailed List of Bargains.

H. L. SMITH and Co., Ltd., 287-9, Edgware Rd., London, W.2. Tel.: Padd. 5891. [6052]

DYNAMOS, ETC.

EVERSHED 600-1,000-volt 30 m.a. Generator, hand or belt drive, perfect; £3/10—48, Balhous Rd., Enfield Wash, N. [6484]

GRAMOPHONES, PICK-UPS, RECORDERS.

TWO B.T.H. Needle Armature Pick-ups, with volume controls, only used for demonstration; 30/- each.—7, Alderney Ave., Lampton. Hantslow 3648 [6502]

LOUD-SPEAKERS.

27/6!!!—Brand new B.T.H.-R.K. speakers, 6v. field, suitable for P.A. work, etc.

£2/7/6!!!—B.T.H. speakers, as above, for 100-250v. A.C., complete with field rectifier.

MAGNAVOX D.C.152 (9in. cone), 22/6; Magnavox 154 (6 1/4 in. cone), 16/3; all with hum-bucking coils, power or pentode transformers and 2,500 or 6,500-ohm fields; Magnavox P.M.254, 18/-; Magnavox P.M.252, 22/6.

ATENTION to All Orders Within 24 Hours; carriage paid; cash with order or c.o.d.

WARD, 2nd Floor, 45, Farringdon St., London, E.C.4. Telephone: Holborn 9703. [6404]

EPOCH Super Cinema M.C. Speaker (low resistance), new; £5/5—59, Carr House Rd., Doncaster. [6486]

SCOTTS.—Speaker bargains: Magnavox, power or pentode, 136 11/6, 154 15/-, 152 20/-; Sixty-Six, 86/6.

ROTHERMEL Brush Piezo electric; H85 38/6, R95 40/-.

BLUE Spot Star P.M. (nickel alloy), 48/6; many other types of speakers in stock; write for lists.—67, Harlesden Gardens, N.W.10 [6515]

BAKER S.P.A.C. Speaker, 250v. 50 cycles, as new, £3; Amplion P.M. speaker, 12lb. magnet, 35/-.—McKean, 150, Dorchester Ave., Kelvinside, Glasgow. [6482]

VAUXHALL.—Magnavox permanent magnets, universal, suitable for Class "B," power or pentode, 6in. cone 15/6, 7in. cone 17/6, 10in. cone 23/-; mains energised, 2,500 or 6,500, 10in. cone, 23/-; 7in. cone 15/3; brand new, with humbucking coils; state power or pentode transformer; unused manufacturers' stock; immediate delivery, carriage paid, cash with order or c.o.d.—Vauxhall Utilities, 163a, Strand W.C.2. Temple Bar 9538. [6458]

VALVES.

4/9—Gecovalve U.X.245 American output valves, unopened cartons, list 15/-, cash with order, postage paid.—Kay, 167, City Road, London, E.C.1. [6491]

METROPOLITAN RADIO SERVICE Co. for American Valves with a Guarantee; any type at keenest prices; trade supplied.—1021, Finchley Rd., Golders Green, N.W.11. Speedwell 3000. [0436]

AMERICAN Valves Direct, 5/- each, three for 12/6, post paid, leading brands, factory fresh, guaranteed; 1A6, 2A7, 6A7, 25Z5, 5Z3, 37, 42, 43, 56, 57, 58, 75, 77, 78, 245, 280; all others at similar prices; send postal order; duty 5d. to 7d. each on delivery; send for lists.—Export Radio Co., 41, Union Square, New York City, U.S.A. [6297]

SURPLUS Valves.—All brand new; battery types, 2-volt, H.F.2, L.F.2, L.P.2, 1/9; super power, P.P.2, 2/6; screens and pentodes, 3/3; A.C. mains, 4-volt 1 amp., general purpose, 3/3; power, 4/-; screens and pentodes, 4/6; full wave rectifiers, 3/6; postage paid, cash with order, or c.o.d. over 10/—Clarion Radio Valve Co., 885, Tyburn Rd., Erdington, Birmingham. [6339]

PREMIER SUPPLY STORES announce the Purchase of the Complete Stock of a World Famous Continental valve manufacturer, all the following standard main types fully guaranteed, 4/6 each: H., H.L., L. power, medium, high, low mag. and variable mu screen grids, one, three and four Watt A.C. output, directly heated pentodes, 250v. 60 m.a. full wave rectifiers, D.C. types, 20v. 18 amp., filaments, screen grid H., H.L. power.

THE Following Types, 5/6 each: 350v. 120 m.a., full wave rectifier, 500v. 120 m.a. full wave rectifier, 2 1/2 watt indirectly heated pentode.

THE Following American Types, 4/6; 250, 112, 171, 210, 245, 226, 47, 46, 24, 35, 51, 57, 58, 55, 37, 80.

THE Following Sizes, 6/6 each: 42, 77, 78, 25Z5, 36, 38, 83, 39, 44, 53, 6A7, 6B7, 2A5, 2A6, 2A7, 2B7, 5Z3, 6C6, 6A4, 6D6, 6F7; the following valve: 866, 25/-.

PREMIER SUPPLY STORES, 20 and 22, High St., Clapham, S.W.4. [6318]

ALL Types of Brand New American Valves in Stock, only first-class makes such as Arcturus and R.C.A. stocked, guaranteed for 6 months, 247, 235, 551, 89, 18, 19, 46, 59, 6A7, 15, 42, 41, 38, 39, 78, 75, 57, 53, 224, 44, 36, 235, 83, 43, 5Z3, 12/-; 25Z5, 12Z3, 14/6; UX171, UX199, UX280, UX245, UX226, UX227, 7/6; UX250, UX210, UX281, 17/6; UX867 photocells, 25/-; all other types of American valves in stock; we also stock transmitting valves, post paid, cash with order or c.o.d.

WARD, 45, Farringdon St., London, E.C.4. Telephone: Holborn 9703. [6517]

COMPONENTS, ETC., FOR SALE.

R**YALL'S RADIO**, 33, Chancery Lane, London, W.C.2 (nearest Tube, Chancery Lane; bus 67 passes door, or tram to Savoy St.), Holborn 3529. Open Saturday afternoon. Close 7 p.m., Saturday 5 p.m., Thursday close 1 o'clock.

R.I. 14-28H. Chokes, second-hand, 10/6; B.T.H. R.K. Junior, corrugated cone, heavy type, 20/-; ex-G.P.O. galvo., 20 m.a., 5/-; Polar twin tub, with drive, 5/-; Polar Star superhet., with drive, 10/-.

HEAYBERD W.31, with H.T.8, new, 30/-; H.T.7, new, with second-hand R.I. transformer with 4v. 6 amps. 22/6; Philips super inductance set, 634A., list £16/16, shop soiled only, £8/8; Ultra Panther console, £12/12.

VARLEY Square Peak B.P. Coils, 2/6; fine set cabinets, room for speaker, to clear, 5/-; large Ormond magnet, only 10/-; set Ferrocart coils, G.1/2/8, new, 20/-.

POLAR Minor, 3-gang Condensers, with "Arcuate," Horizontal or Semi Circular drive, new, list 24/6, 14/6; set three Radiophone coils on base with switch, B.P. Superhet 8/9, post 9d.; Radiophone Radiopacks, 2H.F., with volume control, 32/6, post 1/3.

YAGERPHONE 3v. and Rectifier Chassis Complete, in good order, valves, 65/-; pairs Polar thumb drive 0005 condensers with double eucutcheon plate, 12/6; Ready Radio 0005 extenser condensers, new, 2/6, an be paralalled for S.W. work.

RYALL'S RADIO Offer Reliable Resistances, suitable for all sets where a 1-watt resistance is specified, in values 100, 150, 250, 400, 500, 600, 1,000, 2,000, 5,000, 10,000, 15,000, 20,000, 25,000, 30,000, 40,000, 50,000, 75,000, 100,000, 150,000, 250,000, 1/2 meg., 1 meg., 2 meg., all values stated in ohms, 6d. each; also 2.3-watt type, 100, 700, 800, 1,000, 4,000, 5,000, 6,000, 10,000, 20,000, 9d. each, wire ends.

FERRANTI Transformers, A.F.5, 18/6; A.F.7, 18/6; A.F.9c, 20/-; O.P.M.1, 10/-; O.P.M.1c, 15/6; O.P.M.16c, 15/6; O.P.M.11c, 16/6.

RADIOPHONE Volume Controls with Switch, 5,000, 10,000, 15,000, 20,000, 35,000, 100,000, 2/6; also 10,000 graded 9-1 with 3-P. switch, 25,000 graded 9-1 with 2-P. switch, 3/6 each.

NEW Garrard NollB D/5 Motors, 12in. turntable and fully automatic unit plate, all fittings included; less than half price, 20/-.

MAJNS RADIO DEVELOPMENT COMPANY.

MR.D. Co. Start the Constructor's Season with the Following Perfect and Guaranteed Goods; carriage paid or call, Tudor 4046.

PYE L.F. Chokes, 30h. 60 m.a., 3/6; Daly L.F. transformers, high inductance, 3-1, 4-1, 5-1, 2/-.

POLAR Brass Air-dielectric Reactions, 0.00015 mfd., 9d.; Polar brass standard disc drives, crotchet-on, knob, 1/5.

T.C.C. Dry Electrolytics, 50v. working, 6 mfd. 1/2, 15 mfd. 1/5; Hellesen 8 mfd. wet electrolytics, 435v. working, 2/3.

T.C.C. Condensers, 250v. A.C. working, 2x0.1x0.1x0.1x0.01 mfd., 1/6; 0.1 mfd., 6d.

T.C. 4 mfd. Condensers, 350v. working, 2/4; Ready Radio 50,000 ohm potentiometers, 1/4.

CHASSIS, Cadmium plated, 3-valve, 13 1/2 in. x 7 in. x 2 1/2 in., 1/-; chassis 5-pin valve holders, 2d.

RESISTORS, colour coded, 1 watt, wire end, guaranteed, 100 to 100,000 ohms, 4d. each, 3/6 per dozen; tubular condensers, wire end, 0.0001, 0.0003 mfd., 2d.

MAJNS RADIO DEVELOPMENT COMPANY, 4-6, Muswell Hill Rd., N.6 London. [6480]

STRANGE INTERLUDE.

The day is Sunday.
The scene—the top of Blackpool Tower, the high note specialists up-lifted.
Noah wants to sell us wood for Boffles at "Three happence a foot."
"I lift up my treble and I go tweet, tweet."
We have met the Liverpoolians, the Mancunians AND the ordinary people. We were all pleased to see us all. As at Olympia—"I've come specially to see you." We have come specially to see YOU. If you haven't seen us, there are still two days left to do so.
We've brought HARTLEY-TURNER to the North again. This time, not a lusty infant, but something you have to stop and think about. Why?

Illustrated literature free, but "New Notes in Radio" will cost you 3d.

Hartley-Turner Radio Ltd.

THORNBURY ROAD, ISLEWORTH, MIDDLESEX.
Telephone: HOUnslow 1854.



There was a young lady named Del
Owned a marvellous radio set,
But reception was bad—
It made her quite sad—
NOW it's soldered with FLUXITE—youbet!

See that FLUXITE is always by you—in the house—garage—workshop—anywhere where simple, speedy soldering is needed.

OF ALL IRONMONGERS—IN TINS
4d., 8d., 1/4 and 2/8.

Ask to see the FLUXITE POCKET SOLDERING SET—complete with full instructions—7/6.

Ask also for Leaflet on CASE HARDENING and HARDENING TOOLS with FLUXITE.

THE FLUXITE GUN is a handy and economical tool that enables you to put the Fluxite exactly where you want it on the soldering job.

Also used to project grease into bearings, etc.—like a miniature grease gun.

Just fill the nozzle portion—half fill the cap—put together and press as required. PRICE 1/6.



FLUXITE

IT SIMPLIFIES ALL SOLDERING

FLUXITE LTD. (Dept. W.W.), DRAGON WORKS,
BERMONDSEY STREET, S.E.1.

(This advertisement continued on next page.)

Components, Etc., for Sale.—Contd.

24.
MILDWAY RADIO EXCHANGE Offers the Following Sound and Perfect, cash with order or c.o.d.

MONODIAL 1933 Super for A.C. Mains, complete with valves and wired to specification, less speakers; £12.

RADIOLAB, service tester, listed at £12/12, complete with all adaptors for 4, 5, or 7-pin valves, A.C. or D.C., full voltage and m/amp. ranges; £27/17/6.

FERRANTI Triple Range Meter 0-10 Volt, 0-50 volt, 0-250 volt, 27/6; ditto triple range m.a., 0-7.5 m/amps., 0-30 m/amps., 0-150 m/amps., 32/6; Ferranti 0-150 m/amps., 20/-; ditto 0-50 m/amps., 20/-.

FERRANTI 0-20 amps., 15/-; Sifam 0-200 volts, 15/-; Sifam 0-30 m/amps., 10/-; Sifam M/iron 0-200 m/amps., 6/-; Sifam 0-50 m/amps., 12/6; 0-5 m/amps. moving coil meter, 12/6; Hunts 0-2 m/amps., 15/6.

R.I. Q.P.P. Input and Output, 15/- pair; Varley Q.P.P. output, 8/-; Varley 100 m/amp. chokes, 10/-; ditto 140 m/amps., 12/-; Varley transformer for H.T.1 Westinghouse, 7/6; Ferranti ditto, 7/-; Ferranti for H.T.8, 7/-; Epoch multi ratio output transformer, 8/-.

FERRANTI B.8 L.F. Chokes, 50 m/amps., 4/- each; R.I. Hypercort L.F. chokes, 8/6 each; R.I. Pentomite chokes, 7/6 each; Varley Nicore I transformers, 9/6 each; Hypernik Class B transformer, 6/-; Telsen Class B output, 5/-.

PARMEKO 425-425 4.2, 4.3 amps. mains transformer, 25/-; Varley 500x500 120 m/amps. with L.T. tappings, 25/-; R.I. 250x250, 4v. 3a., 4v. 1a., 4v. 3a., 17/-; Varley 4 volt 5 amp. filament transformer, 8/-.

FERRANTI A.F.4, 7/6; A.F.3, 10/6; A.F.5, 18/-; A.F.6, 18/-; A.F.7, 18/6; A.F.7c, 20/-; B.1, 10/6; B.8, 4/-; O.P.1, 1-1 ratio, 7/-; O.P.2, 25-1, 7/6; O.P.M.1, 10/-; O.P.M.1c, 14/-; O.P.M.2, 10/-; O.P.M.4, 12/-; O.P.M.12c, 7/6; O.P.M.17c, 8/6; O.P.3c, 1-1 P.P., 7/6.

COLVERN 2K.B.1c and I.K.G.R., 17/6; Ferrocart G.1, G.2, G.8, 17/6; G.10, G.11, G.14, 20/-; Lissen superhet coil, 10/- set; Telsen superhet coils, 10/- set; Lewcos and Wearite superhet coils, 4/- each; Radiophone 3-gang 0.0005 with cover, 9/6.

SPECIAL Offer Regentone A.C. Mains Units.

TYPE W.I.F. Output, 150 volts, 12 m/amps., 27/-, listed 50/-; type W.I.C. output 150 volts, 20 m/amps., 30/- each, listed at 55/-; all brand new in sealed boxes.

TYPE W.5A. with Trickle Charger, output 150 volts, 20 m/amps., for 2, 4, or 6 volt accumulator, 37/- each, listed £3/15; type D.C.1 for D.C. mains, output 150 volts, 25 m/amps., 22/6 each.

EKCO Type K25, output 150 volts, 25 m/amps., with 4 tappings, 2 variable, also charger for 2, 4, or 6 volt accumulator, listed £5/7/6, our net price, 39/-.

THE Above Post or Carriage Paid.

OPEN All Day Thursday, Closed Saturday.

PHONE: Clissold 5001.

24. Mildmay Grove, London, N.1. [6518]

PREMIER SUPPLY STORES

OFFER the Following Manufacturers' Surplus New Goods at a Fraction of the Original Cost; all goods guaranteed perfect, carriage paid over 5/-, under 5/- postage 6d. extra, I.F.S. and abroad, carriage extra. Order under 5/- cannot be sent c.o.d. Please send for illustrated catalogue post free.

STUPENDOUS Purchase of Set Manufacturers' Stock.—All electric 3-valve (S.G. det. pen.) set, in walnut cabinet, with moving coil speaker, 200-250 volt 40-60 cycles, chassis built, 200-2,000 metres, with 4 valves; £4/19/6.

ALL-ELECTRIC 3-stage Amplifiers, 200-250v., 40-60 cycles, 10 watts undistorted output, complete with 5 valves, £7/7; suitable speakers, pick-ups and microphone can be supplied.

TYPE 4480, 9in. diameter, permanent magnet, handles 4 watts, 7 ohms speech coil, 13/6; multi ratio transformer, 4/6 extra.

ELMINATOR Kits, including transformer, choke, Westinghouse metal rectifier, condensers, resistances and diagram, 120v., 20 m.a., 20/-; trickle charger, 8/- extra; 150v. 30 milliamps., with 4v. 2.4 amps. C.T., L.T., 25/-; trickle charger, 6/6 extra; 250v. 60 milliamps., with 4v. 3-5 amps. C.T., L.T., 30/-; 300v. 60 m.a., with 4 volts 3-5 amps., 37/6; 200v. 50 m.a., with 4v. 3-5 amps. L.T., 27/6.

PREMIER Chokes, 40 milliamps, 25 hys., 4/-; 65 milliamps., 30hys., 5/6; 150 milliamps, 30 hys., 10/6; 60 milliamps, 80 hys., 2,500 ohms, 5/6; 25 milliamps, 20 hys., 2/9.

ALL Premier Guaranteed Mains Transformers Have Engraved Terminal Strips, with terminal connections, input, 200-250v., 40-100 cycles, all windings paper interleaved.

PREMIER H.T.7 Transformer, output 135v. 80 m.a., for voltage doubling, 8/6; 4v. 3-4a., C.T. L.T., 2/- extra; with Westinghouse rectifier, giving 200v. 30 m.a., 17/6.

PREMIER H.T.8 and 9 Transformers, 250v. 60 m.a. and 300v. 60 m.a. rectified, with 4v. 3-5a. and 4v. 1-2a. C.T. L.T. and screened primary, 10/-; with Westinghouse rectifier, 18/6.

PREMIER H.T.10 Transformer, 250v. 100 m.a., rectified with 4v. 3-5a., and 4v. 1-2a., C.T. L.T., and screened primary, 10/-; with Westinghouse rectifier, 19/6.

PREMIER Mains Transformer, output 250-0-250v. 60 m.a., 4v. 3-5a., 4v. 2-3a., 4v. 1-2a. (all C.T.), with screened primary, 10/-.

(This advertisement continued on next page.)

Components, Etc., for Sale.—Contd.

(This advertisement continued from previous page.)

PREMIER Mains Transformers, output 350-0-350v. 90 m.a., 4v. 3-5a., 4v. 2-3a., 4v. 1-2a. (all C.T.), with screened primary; 10/-.
PREMIER Auto Transformers, 100-110/200-250v. or vice versa, 100-watt; 10/-.

WESTERN ELECTRIC Mains Transformers, 300-0-300v. 65 m.a., 4v. 1-2a., 4v. 2-3a. 6/6; 500-0-500v. 150 m.a., 4v. 3-5a., 4v. 2-3a., 4v. 1a. C.T., 4v. 1a. C.T., 19/6.

SPECIAL Offer of Mains Transformers, manufactured by Phillips, input 100-200v. or 200-250v. output 180-0-180 volts 40 m.a., 4v. 1 amp., 4v. 3 amps., 4/6; 200-0-200v., 4v., 1a., 4v. 3a., 4/6.

PREMIER I.T. Charger Kits, consisting of Premier transformer and Westinghouse rectifier, input 200-250v., A.C., output 8v. 1/2 amp., 14/6; 8v. 1 amp., 17/6; 6v. 2 amp., 27/6; 30v. 1 amp., 37/6; 2v. 1/2 amp., 11/-.

B.T.H. Trusped Induction Type (A.C. only) Electric Gramophone Motors, 100-250v.; 30/- complete.

SPECIAL Offer B.T.H. Gramophone Motors, A.C. and D.C. 100-250v.; 30/-, listed £3/3.

COLLARO Gramo. Unit, consisting of A.C. motor, 200-250v. high quality pick-up and volume control, 49/-; without volume control, 46/-.

EDISON BELL Double Spring Gramophone Motors, complete with turntable and all fittings, a really sound job; 15/.

SPECIAL Offer of Wire Wound Resistances, 4 watts, any value up to 50,000 ohms, 1/-; 8 watts, any value up to 15,000 ohms, 1/6; 15 watts, any value up to 50,000 ohms, 2/-; 25 watts, any value up to 50,000 ohms, 2/6.

WIRE Wound Potentiometers, 15,000 ohms, 1/6; 50,000 ohms, 2/-; 500,000 ohms, 3/-; 1,000 ohms wire-wound semi-variable resistances, carry 150 m.a., 2/-.

CENTRALAB Potentiometers, 400 ohms, 1/-; 50,000, 100,000, 1/2 meg., any value, 2/-; 200 ohms, wire wound, 1/-.

POLAR Star, manufacturers' model, 3-gang condensers, fully screened; 7/6, with trimmers.

AMERICAN Triple Gang 0.0005 Condensers, with trimmers, 4/11; Utility bakelite 2-gang 0.0005, screened, with unknob trimmer, 3/6; Polar bakelite condensers, 0.00035, 0.0003, 0.0005, 1/-.

ORMOND Condensers, 0.0005 2-gang semi-shielded, 2/6; brass vanes, with trimmers, 3/6; British Radiophone 110 kc/s intermediate, 3/-.

MAGNAVOX D.C. 152, 2,500 ohms, 17/6; D.C. 154, 2,500 ohms, 12/6; D.C. 152 magna, 2,500 ohms, 37/6, all complete with jam-bucking coils; please state whether power or Pentode required; A.C. conversion kit for above types, 10/-; Magnavox P.M. 7in. cone, 18/6.

RELIABLE Canned Coils with Circuit, accurately matched, dual range, iron cored; 3/6.

RELIABLE Intervale Transformers, 2/-; multi-ratio output transformers, 4/6.

T.C.C. Electrolytic Condensers, 550v. working, 650v. peak, 8 mf., 4/-; 4 mf. or 8 mf. 440v. working, 3/-; 15 mf. 50v. working, 1/-; 25v. working, 25mf., 1/3; 6 mf., 50v. and 2 mf. 100v. working, 6/-; 8-4 mf., 450v. working, 4/-; 50 mf., 50v. working, 2/9.

T.C.C. Condensers, 250v. working, 1 mf. 1/3, 2 mf. 1/9, 4 mf. 3/-; 4 mf., 450v. working, 4/-; 4 mf., 750v. working, 6/-.

H.M.V. Condensers, 400v. working, 4+4+1+1+1+1+0.1+0.1+0.1+0.1, 4/8; 4+2+1+1+1+1+0.5, 3/9.

DUBILIER Condensers, 8 or 4 mf., dry electrolytic, 450v. working; 3/-.

VARLEY Constant Square Peak Coils, band-pass type B.P.7, brand new, in maker's cartons, with instructions and diagrams; 2/4.

VARLEY H.F. Intervale Coils, B.P.8, band-pass, complete with instructions, in original cartons; 2/6.

SCREENED I.F. Chokes, by one of the largest manufacturers in the country; 1/6.

PREMIER British-made Meters, moving iron flush mounting, accurate 0-10 0-15 50 m.a., 0-100 0-250 m.a., 0-1, 0-5 amps; all at 6/-.

LARGE Selection of Pedestal table and radiogram cabinets, by best manufacturers at a fraction of original cost, for callers.

THE Following Lines 6d. each, or 5/- per dozen.— Chassis valve holders, 5-, 6- or 7-pin, screened screen-grid leads, any value 1-watt wire end resistances, wire end condensers, 0.0001 to 0.1, Bulgin 3-amp. main switches; Cylcon capacitors, double trimmers.

PREMIER SUPPLY STORES.

20-22, High St., Clapham, S.W.4. Phone: Macaulay 2188. Nearest station: Clapham North, Underground. [6520]

SCOTTS' Radio Bargains.—Set manufacturers' guaranteed surplus.

SCOTTS' Kit, guaranteed parts for "W.W." Olympic S.S. Six, including valves, £14/10; 1935 A.C. short wave receiver, with valves, £9/12/6; from stock.

SCOTTS.—Transformers for short wave receiver, 12/6; Single Span, 19/-; S.S. Olympic coils, 45/-; S.S. span coils, 34/-, to specification.

SCOTTS.—Pick-ups: Marconi K19 or M25, 21/6; Celestion P2, 16/-; Cosmocond, 12/-; Rothermel piezo electric, 30/-.

SCOTTS.—Rectifiers: Westinghouse H.T.6, 7, 8, 9/-; 9, 10, L.T.4, 5, 10/-; Westectors, W4, W6, 4/6; W.M.24, 26, 6/6.

SCOTTS.—Resistances: Dubilier, etc., 1 watt, all values, 6d.; electrolytic condensers, Dubilier and T.C.C., 4, 8, 50 mf., 3/-.

SCOTTS.—Gram-motors, Garrard, Autochangers, with Piezo Astatic pick-up, £7/10; Cosmocond grammo. chassis, model 55, with pick-up and autostop, 35/-.

SCOTTS.—Valves: American and non-ring European, also transmitting valves in stock; write for transformer and component list.—67, Harlesden Gardens, N.W.10. [6512]

Components, Etc., for Sale.—Contd.

WOBURN RADIO Offer Following Manufacturers' Surplus:—

UTILITY 0.0005 Condensers with disc drive and escutcheon, 3/6; twin gang 0.0005, with trimmers, and disc drive, mica dielectric, 3/6; three-gang 0.0005, with trimmers, semi-screened, 4/-; Lissen output transformers, 23/1, 3/6; Glass B drivers and chokes, 8/6, with B.V.A. valve, 15/6; chassis valve-holders, 4-5-pin, 1/3 half dozen; Polymet 0.0001 tag condensers, 1/- half dozen; Edison Bell 0.002, 0.005, 0.006, 1/3 half dozen; popular iron-cored canned coils, 2/6; Eston iron-cored coils, 2/6.

MERSHOM 8 mfd. 500v. Electrolytics, 2/9; Wego bakelite condensers, 750v. test, 1 mfd., 1/-; 2 mfd., 1/3; 4 mfd., 2/3; Dubilier 2 mfd., 1,000v. test, 1/4; H.F. chokes, 1/-; binocular chokes, 1/3; Columbia L.F. transformers, 3-1 and 5-1, 3/-; tubular condensers, 0.1, 0.01, 0.02, 6d.; toggles, 6d.; Radiophone straight line dials, with escutcheon and dial lights, 3/9; screened flex, 6d. yd.; 7-way battery cord, 6d. yd.; resistances: parcels of 13 wire wound resistances, Truwind, accurate 1%, 1 1/2 watt, values 100 to 75,000 ohms, 3/9; Western Electric microphones, very sensitive, 2/3; microphone transformers for use with same, 85-1, 2/3.

W.R.C. Eliminators, 150v. 30 m.a., all guaranteed 12 months, D.C. 9/6, A.C. 21/-; Universal A.C./D.C., 21/-; A.C. with trickle charger, 32/6; trickle chargers, 12/6; all have 3 positive H.T. tappings, carriage 1/- extra on all models.

TRADE List Now Ready. Please enclose business heading and stamp.

WOBURN RADIO Co., 9, Sandland St., Bedford Row, W.C.1. Just off Red Lion St., Holborn, Holborn W289. [6465]

SOUTHERN RADIO'S Bargains.—Set manufacturers' guaranteed surplus.

VARIABLE Condensers.—Lotus 3-gang 0.0005, 12/6; Lotus 2-gang, 0.0005, 8/6; Lotus Dyalock single, 0.0005, 4/9 (list 9/6); all these condensers are complete with dials, escutcheons, knobs, fully screened with trimmers and boxed; Hydra block condensers, 16 mfd. (2+2+3+2+1+1), 1,000v. D.C., 7/- each; Dubilier 4 mfd. for mains noise suppression, 3/-; Utility Midget 2-gang variable condensers, 0.0005, with concentric trimmers, 3/5; T.C.C. 0.1+0.1, 1/3 each.

SPEAKERS. Blue Spot permanent magnet, with universal transformer for power, super power, pentode and Class B; 23/- (list 39/6).

G.E.C. Stork Speaker in Cabinet; 19/6 (list £3/15).

S.T.400 Kits, all specified proprietary components; £2/19/6 (list £4/17/6).

REGENTON A.C. Eliminators, type W.5A., combined with trickle charger, 20 milliamps., brand new and sealed; 39/6 (list £4/12/6).

IRANIC Superhet Coils, set of 4 (1 Osc., 2 I.F., with pigtails, 1 L.F. plain); 12/6 (list 50/-).

LISSÉN Superhet 3 Coils Kit, screened, ganged on base with wave change and filament switches; type L.N.5181, for battery or mains; 12/6 (list 30/-).

VARLEY Constant Square Peak Coils, complete with all accessories, new, boxed, B.P.5; 2/4.

VARLEY H.F. Inter-valve Coils, B.P.6; 2/3.

FRAME Aerials.—Lewcos dual wave superhet; 9/- each (list 27/6).

PICK-UPS.—Marconi No. 19 (1934), 22 6 each (list 32/6).

READY Radio Instamat Transformers, for matching any valve to speaker; Junior model, ratios 1: 2, 1: 1, 1 1/2: 1, 2: 1, 3: 1, 7/6 (list 27/6); Senior model, ratios 10: 1, 12 1/2: 1, 14: 1, 16: 1, 20: 1, 25: 1, 12, 6 (list 37/6).

RECEIVERS.—3-valve screen-grid Elector Super, complete with valves, Exide batteries and accumulator, Celestion moving coil speaker, contained in magnificent walnut cabinet, £3/10 (list £10).

OSRAM Thirty-Three Music Magnet, complete with G.E.C. speaker, 2 Osram screen-grid and Osram power valves in moulded bakelite walnut cabinet; £3, 12, 6 (list £9/9); in original sealed cases.

BOTOLPH Lightweight Portable Receivers, complete with valves, Exide batteries and accumulator, overall size 13in. x 11in. x 8in., £2/19, 6 (list £8/8); a real suitcase portable.

READY Radio Meteor Screen-grid 3-valve Kits, all specified components new, in sealed cartons; 25/-, less valves; with 3 Mullard valves, 42/6 (list £5, 7/6).

A Kit, as above, complete with magnificent walnut cabinet and Celestion perm. mag. speaker, less valves, £3/5; with 3 Mullard valves, £4, 2/6 (list £8/17/6).

MULLARD Radio for the Million, "Station Master Three" battery kits, complete with cabinet and 3 Mullard valves (screen grid, H.L., power), brand new in original sealed cartons; £2/19/6 complete.

MISCELLANEOUS.— Westinghouse metal rectifiers, H.T.6, 7, 8, 9/3 each; Ferranti chokes, 20 henry 60 m.a., 6/9 each; Lewcos superhet, 8-way bases, complete with valve holders, grid leak, fixed condenser, type "48", 2/- each; Lissen base turntables, 1/6 (list 5/-); Lewcos coils, B.P.F./R., 4/-; T.B.F./C., 3/3; O.S.C. 126 (Extensor), 3/3; T.O.S./R., 3/3; Morse tapping keys, with buzzer and flashlight signal, complete with battery and bulb, 2/- each.

VALVES.—Brand new guaranteed American valves, all types; please ask for quotations.

ALL Goods Guaranteed and Sent Carriage Paid.

BRANCHES at 271-275, High Rd., Willesden Green, N.W.10, and at 46, Lisle St., W.C.2. Please send all post orders to 323, Euston Rd., N.W.1.

SOUTHERN RADIO, 323, Euston Rd., London, N.W.1 (near Warren St. Tube). Phone: Museum 6324. [6507]

Do You Know What This Graph Means?

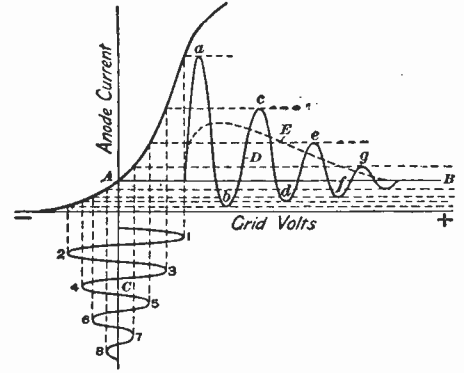

The man who can analyse these curves and understand what they indicate knows his job. But if they do not convey to him perfectly definite information, it would appear that he needs more training than he has had. He is not competent to fill a responsible position in wireless.

Radio has developed so rapidly throughout the last ten years that it has now greatly outgrown the supply of technically qualified men required for the better posts. Moreover, it continues to develop with such speed that only by knowing the basic principles can pace be kept with it.

The I.C.S. Radio Courses cover every phase of radio work. Our instruction includes American broadcasting as well as British wireless practice. It is a modern education, covering every department of the industry.

OUR COURSES

Included in the I.C.S. range are Courses dealing with the installing of radio sets and, in particular, with their Servicing, which today intimately concerns every wireless dealer and his employees. The Operating Course is vital to mastery of operating and transmitting.

There is also a Course for the Wireless Salesman. This, in addition to inculcating the art of salesmanship, provides that knowledge which enables the salesman to hold his own with the most technical of his customers.

Then there are Preparatory Courses for the City and Guilds and I.W.T. Exams.

We will be pleased to send you details of any or all of these subjects. Just fill in, and post the coupon, or write in any other way.

International Correspondence Schools, Ltd., Dept. 38, International Buildings, Kingsway, London, W.C.2.

Without cost, or obligation, please send me full information about the Courses I have marked X

- COMPLETE RADIO
- RADIO SERVICING
- RADIO EQUIPMENT
- RADIO SERVICING & SALESMANSHIP
- WIRELESS ENGINEERING
- WIRELESS OPERATORS
- EXAMINATION (state which)

Name Age

Address

Components, Etc., for Sale.—Contd.

GILBERT INDUSTRIES Sensational Start to the New Season.
P.A. Amplifiers, brand new, 6 watts undistorted output, using 2PX4's.
LATEST Auto-coupled Circuit, including remote control, input transformer, high capacity smoothing and choke filter output.
A STEEL Chassis, custom built job, available owing to broken contract.
READY to Work, less valves, at 65/-; carefully packed and post paid (few only with valves).—Gilbert Industries, Ltd., 519, London Rd., Westcliff-on-Sea. 'Phone: Southend 492071. [6363]

1/6—Cadmium plated chassis, 4-valve, pressed steel, 14x9; post 6d.
4/9—200/250 transformers for H.T.8 or H.T.9, brand new in cartons.
1/9—Viking dual aperture dial in station and degrees with large bronze escutcheon and walnut knob, list 8/6; ditto British Radiophone drum drive, 2/3; cash with order, postage paid.—Kay, 167, City Road, London, E.C.1. [6490]

EPTON Here Again, with brand new and guaranteed surplus snip bargains!
13/6 Will Buy 22/6 Cosmocord 1934 Pick-up, complete with balanced tone arm, volume control, rest, etc.
7/6 Will Buy Any One of These American Valves: 227, 245, 80; 10/6 for 224, 47, 35, 51, 25Z5, 77, 78, 36, 38.
45/- Will Buy a Celestion £6/10 P.P.M.79 De Luxe P.M. Speaker (with Universal transformer), in handsome walnut, mahogany, or oak cabinet, in original carton.
EPTON, 93, New Rd., Chingford, E.4. (Cash with order, or c.o.d.) [6460]

PEARL and **PEARL** Bargain List A Free.—190, Bishopsgate, London, E.C.2. [0421]

UTILITY SALES, 27a, Sale St., W.2, offer following special bargains; write for catalogue.
CELESTION P.M.M.W. M.C. Speaker (45/- list), 17/6; Baby model Soundex, 12/6.
EKCO T.C.1 ½ amp. L.T. Charger, 1934 model (£2/7/6 list); 17/6; guaranteed.
REGENTONE Eliminator, W5A, with L.T. charger £4/12/6 list; 35/-; splendid job.
TRANSFORMER, standard cable, 200/240, 300-0-300, 60 m.a., 4v 3a. C.T., 4v. 2a.; 8/6, worth 21/-.
IGRANIC Band-pass Iron Core Coils, screened, dual wavelength (33/- list); 14/6, snip.
IRON Core Screened Matched Coils, 3 circuits, 2/6; Lucerne, 2/6, plain, 2/-.
MICROPHONES, Western Electric, hanging 2/6, hand 3/6, transformer 3/6; table model, containing transformer, 8/6. handsome job; diagrams free; buttons, tested, 1/-.
ELECTRIC Soldering Iron, 4/6; De Luxe model, reversible bit engineer's type, 7/6.
ELECTRIC Wonder Battery Clock, mahogany bakelite, battery lasting year, guaranteed; 15/-.
LOTUS Dyblock 0.0005 Variable Condenser, disc drive, lamp, escutcheon, complete, 4/6; 2-gang, 8/3; 3-gang, 12/3.
CELESTION W8 Pick-up (35/- list), new, boxed, 16/6; Cosmocord latest model, 12/6.
SONOCHORDE Energised M.C., 2,500 ohm, 7½in., 12/6; Rothermel Baby P.M., marvellous job, 13/6.
UTILITY SALES, 27a, Sale St., Paddington, London. [6511]

WARD for Unparalleled Bargains in Set Manufacturers' Surplus; all goods are guaranteed perfect; immediate delivery.
OLYMPIC S.S. Six Coils, complete to specification, 45/-; A.C. and D.C. eliminators, first class make, tappings S.G., detector and power (150v., 25 m.a.); A.C. type, with Westinghouse rectification 25/-; D.C. type 12/-.
DUBILIER Resistances, 1-watt type 7d., 2-watt type 1/2, 3-watt type 1/9; Dubilier or T.C.C. dry electrolytic condensers, 8 mfd. or 4 mfd., 500v. peak, 50v., 50 mfd. or 200 mfd., 10v. peak, 3/6.
MARCONI K19 or K25 Pick-ups, 21/-; Rothermel piezo electric, 30/-; Cosmocord, 12/-; B.T.H. needle armature pick-ups, 29/-; B.T.H. pick-up tone arms, 3/-; Clix chassis type valve holders, 5-pin 5d., 7- or 9-pin 6d.; T.C.C. type "M" fixed condensers, any size up to 0.001 mfd., 6d.
WESTINGHOUSE Rectifiers, H.T.8 9/6, H.T.9, H.T.10, L.T.4, L.T.5, 10/9; transformers (Regentone), for H.T.8 or H.T.9, with 4v. 4a. L.T., 7/-.
CARRIAGE Paid, cash with order or c.o.d.; send for list.
WARD, 45, Farringdon St., London, E.C.4. Tel.: Holborn 9703. [6516]

FERRANTI A.F.5 and A.F.7, 15/- each; A.F.5(c), 17/6; O.P.M.4 (c), 13/-.—Young, 151, Lower Richmond Rd., Mortlake. [6467]

SEVERAL New Sets, from 50/-; large quantity of new components, public address gear, etc.; offers accepted; list.—33, Baden Rd., Brighton. [6483]

FERRANTI A.F.5, 15/-; Tungstram 2, P.2018's, R.2018, S.E.2018, S.E.2118, 30/-; T.C.C. 2,000+2,000 mfd., 12v., 5/-; H.T. transformer, about 10,000 volts, 10/-; stamp for reply.—27, Ravensdale Av., N.12. [6500]

FERRANTI—A.F.3, 9/6; O.P.3C., 11/-; 0-200 M.C. milliammeter, 19/-; Varley Nicore 1, 7/6; B.T.H. R.K. energised M.C. speaker, d.c., 15/-; Milgate, ditto, 10/-; c.o.d. if required.—G. Hillingworth, 11, Greenfield Av., Hawksworth, Guiseley, Leeds. [6497]

FERRANTI A.F.3, 10/6; A.F.4, 7/6; A.F.5, A.F.6, A.F.7, 11/6; A.F.5c, 11/6; A.F.5c, 19/-; A.F.15c, 15/-; O.P.M.1, O.P.M.1c, O.P.M.2, O.P.M.2c, O.P.M.3, O.P.M.5c, 13/6; O.P.1, O.P.3c, 8/6; B.1 choke, 11/6; B.2, 11/6; 0-15 milliammeter, 18/6.—Bostock and Stonnill, 1, Westbourne Terrace, S.E.23. [6495]

Components, Etc., for Sale.—Contd.

BIRMINGHAM RADIOMART Announces Purchase of Set Manufacturers' First Quality Radio Components, all guaranteed new and perfect goods.
RADIOMART—Utility super quality 5-gang air-spaced ball bearing, fully screened with trimmers, list price 24/-, straight or superhet; 6/6.
RADIOMART—Utility 2-gangs, as above, 5/10; Utility dials to fit either, 2/-.
RADIOMART—Utility single 0.0005 or 0.0003, with full size disc drive, walnut knob escutcheon, 2/-.
RADIOMART—Igranic smoothing chokes, 20hy., 100 m.a., 260 ohms, heavy stalloo core, 2/9.
RADIOMART—Edgewise visual tuning meter, 6 m.a., illuminated, 2¼x½in. only, similar R.G.D., 5/9.
RADIOMART—Ekco A.C.18 eliminators, 18 m.a., list £3/7/6, 29/6; ditto K.18, with charger, list £4/17/6, 37/6.
RADIOMART—Radiophone logarithmic potentiometers, 10,000 ohms, wirewound, with mains switch, 2/-; 5,000, no switch, 2/-.
RADIOMART—Radiophone straight line degree dials, illuminated, complete escutcheon knobs, 3/6.
RADIOMART—Cosmocord 1934 pick-up, with volume control and rest, 12/-; confidently recommended.
RADIOMART—Screened iron-cored dual range coils, with reaction circuit, 2/11; Igranic short-wave ditto, 3/3.
RADIOMART—Igranic Parvo 3½-1, list 8/6, 2/11; Philco "Class B" driver, 2/9; Voltra 8/6 L.F., 2/-; Ericsson 15/- L.F., 1/6.
RADIOMART—Centralab 1-watt colour-coded resistances, all values, 6d.; Truewind wirewound colour-coded, 2/- dozen; our assortment only.
RADIOMART—Aerovox 8x8 mfd. 435v. dry electrolytics, 3/6; Hellesen, wet 8 mfd. 435v., 2/9.
RADIOMART—Varley B.P.5 band-pass coils, list 15/-, with circuit, improved selectivity, 2/4.
RADIOMART—Cadmium 5-valve chassis, 1/6; grey cellulose 4-valve, 9d., postage 6d. extra.
RADIOMART—Magnum radiogram dissolvers, 2/9; wirewound potentiometers, Magnum 25,000, Colveru 2,500, 15,000, 1/6.
RADIOMART—Metvick H.F. chokes, 9d.; Lewcos screened anode leads, 3d.; Belling Lee plain terminals, 1/- dozen.
RADIOMART—Telsen differentials, boxed, complete knob, 0.0001, 0.00015, 1/-; 0.0003, 0.00035, 1/3.
RADIOMART—Telsen wirewound potentiometers, 10,000, 50,000, 1/6; Telsen mains transformers, 50, 25 cycle, 12/6.
RADIOMART—Non-inductive tubulars, wire-ended, 1,500v., 0.1 mfd., 0.01, 0.02, 0.05, 6d.; Phillips ditto, 0.0001, 0.001, 2d.; 0.25, 0.5, 9d.; T.C.C. 0.25, 1/-.
RADIOMART—Metvick transformer kit, laminations, clamp, sectional bobbin terminals, complete, 3/6.
RADIOMART—Electrad Royalty 50,000, 100,000, 250,000, potentiometer, 1/6; 400 ohm. potentiometers, 6d.
RADIOMART—Utility 1934 mica variables, 0.0005, 10d.; 0.0003, 8d.; 0.0002, 0.0001, 6d.; 0.0003, differentials, 1/6.
RADIOMART—G.5N.I., short-wave specialists; read test report *Wireless World* last week.
RADIOMART—Short-wave H.F. chokes, 9d.; Frequentite valve-holders, 6d.; Frequentite anode connectors, screened, 1/-.
RADIOMART—Microvariables, 15, 40, 100 mfd., 1/3; super all-brass, 0.0001, short-wave pigtail, 1/9.
RADIOMART—R.I. special 300 hy. chokes, 7/6; Lewcos 6-way cable, 4d. foot.
RADIOMART—Western Electric 21/. microphones, 2/9; transformer 2/6; Beehive standoff insulators, 8d.
RADIOMART—Milliammeters, ammeters, flush, nickel, 2½in., 5/9; super ditto, 2½in., 6/9; Read A.C. or D.C.; all ranges.
RADIOMART—Latest list contains hundreds similar bargains; stamp essential.
RADIOMART—Orders over 6/- post free.—The Square Dealers, 19, John Bright St., Birmingham. [6503]

VAUXHALL—Radiophone, Radiopaks, complete with volume control and Lucerne station named scale and escutcheon, state type, 32/6; intermediate transformers for above, with terminals, 6/-; coils, set of 3 on base with switch and terminal, 16/6; 3-gang condensers, superhet., 14/6; ordinary type, 12/6; disc drives, complete, 4/9.
VAUXHALL American Rola F6, 2,500 or 6,500, 17/6; F7, 25/-; with humbucking coils, power or pentode, permanent magnets, universal transformers, 8in. diameter 28/-, 10in. 35/-; Collaro gramophone motors, and B.T.H. Trusped. A.C. only, 32/6; complete units, with pick-up, etc. 48/6
VAUXHALL—Pick-ups from 3/- to £2; state make for quotation; volume control all values, with switch and knob, 3/6; gramophone switches, 3/6.
VAUXHALL—Benjamin, Class B transformers, 1-1½ to 1, 6/6; Radiophone, Class B, 10/-.
VAUXHALL—Westinghouse rectifiers: H.T.8 9/6, H.T.9, H.T.10 10/-; Westectors W4, W.X.6, 5/9; Clix valve holders, 7-pin, 7d.; W.B., 4-5-pin, 4½d.; send postcard for lists; post paid 2/6 or over or c.o.d.
VAUXHALL UTILITIES, 163a, Strand, W.C.2, after Denny's the Booksellers, Temple Bar 9338. [6459]

METAL Chassis, 5/-; Polar gang condensers and dial, 15/-; set coils, 30/-; set chokes, 5/-; foregoing for "W.W." Straight Four; pair dual Magnavox Magna speakers, 50/-; Gerard automatic record change gramophone, £6/10; mixer beater, £5; Gambrell Novotone, 10/-; A.F.5C. transformer, 10/-; O.P.M.I.C. transformer, 10/-; all perfect, mostly unused.—Capper, 90, Westbourne Rd., Sheffield. [6478]

Components, Etc., for Sale.—Contd.

RADIO CLEARANCE, 94, High Holborn, W.C.1, offers the following stupendous bargains; limited quantities only; all goods carriage free.—'Phone: Holborn 4631.
RADIO CLEARANCE—Grampian 5-valve Super-Het. for A.C. mains, size 12x8½, completely wired chassis, incorporating A.V.C., pentode output, valve rectification, for use with field energised moving coil speaker, 2,000 ohms, suitable for 200-250 volts, wired for pick-up, complete with knobs and escutcheon; 42/6, carriage paid.
RADIO CLEARANCE Offers Plessey Triple Gang Condensers, 2x0.0005 and 110 K/c oscillator section, complete with knob, drive and escutcheon; 8/6, post free.
RADIO CLEARANCE Offers Plessey 110 K/cs Intermediate Frequency Transformers; 3/-, post free.
RADIO CLEARANCE Offers 8,000 ohm Volume Controls, log. type, with Q.M.B. switch, by G.E.C.; 2/6, post free.
RADIO CLEARANCE Offers Mains Transformers, unshrouded, manufacturer type, primary 200-250, secondary 320-0-320, at 70 m.a., 2-0-2v. at 2½ amps., 2-0-2v. at 3 amps.; 8/6, post free.
RADIO CLEARANCE Offers Mains Transformers, shrouded, with terminals, primary 200-250v., secondaries 320-0-320 at 70 m.a., 2-0-2 at 2½a., 2-0-2 at 4½a., 9/6, post free.
RADIO CLEARANCE Offers Mains Transformers, shrouded, with terminals, primary 200-250v., secondaries 320-0-320 at 70 m.a., 2-0-2 at 2½a., 2-0-2 at 6½a., 10/6, post free.
RADIO CLEARANCE Offers Steel Chassis, cadmium plated, drilled ready for use, 3-valve, 5-valve, or 7-valve type; 1/6, post free.
RADIO CLEARANCE Offers Set of Band-Pass Coils, manufacturer's type, with circuit diagram, suitable for tuned grid or tuned anode; set of 3 coils, 4/6, post free.
CENTRALAB Potentiometers, 25,000, 50,000 ohms; 1/6 each, post free.
RADIO CLEARANCE Offers Set of Super-Het. Coils, comprising Band-Pass and Oscillator 110 K/cs for cathode injection with circuit diagram; 4/6, post free.
RADIO CLEARANCE Offers Parallel Feed Transformers, ratio 6-1, by well-known manufacturer, 3/-.
RADIO CLEARANCE—T.C.C. condensers, 0.5 mfd., 800-volt, D.C. working, 2/- each; T.C.C. condensers, 1 mfd., 250-volt, D.C. working, 1/- each; T.C.C. condensers, 1 mfd., 450-volt, D.C. working, 1/3 each; T.C.C. condensers, 1 mfd., 750-volt, D.C. working, 3/- each; T.C.C. condensers, 2 mfd., 450-volt, D.C. working, 2/- each; T.C.C. condensers, 4 mfd., 450-volt, D.C. working, 3/- each; T.C.C. condensers, 4 mfd., 500-volt, D.C. working, 3/6 each; T.C.C. condensers, 6 mfd., 250-volt, D.C. working, 2/6 each; T.C.C. condensers, 6 mfd., 350-volt, D.C. working, 3/- each; T.C.C. condensers, 4 mfd. block, 0.5, 0.5, 0.5, 0.5, 0.5, and 1 mfd., 250-volt, A.C. working, 2/- each; Phillips Eliminator transformers, 150 volts at 30 milliamps., 4 volts, 1 amp., various inputs, 1/6; Phillips smoothing chokes, 14-28 henries, 120 milliamps, 2/- [6510]

PIONEER RADIO MANUFACTURING Co., Ltd., offers: Ericsson 3-1 L.F. transformers, list price 17/6; new and guaranteed, our price 2/3, post free U.K.; Varley constant square peak band-pass coils, type B.P.5, complete with switch, brand new, in makers' original carton, with full instructions and diagrams, list price 15/-, our price 2/4, post free U.K.; Celestion energised M.C. speaker, 2,500 ohms, model D.C. 2054, with universal transformer, list price £2/5, our price 12/6; bankrupt set manufacturers' stock. [6425]

MISCELLANEOUS.

EVERYTHING for Movies.—Cameras and Projectors from 20/-; screens from 5/-.
ILLUSTRATED ENTERPRISES, 159, Wardour St., London, W.1 (facing Film House, Oxford St. end); not a shop, but a warehouse packed with motion-picture equipment; your inspection invited. 'Phone: 6889 Gerrard; free parking facilities. [5936]

SHEET Metal Work in Any Material; send particulars for quotation.—Wedge Bros., Little Bricklin St., Wolverhampton. [6474]

EMPLOYERS are searching for Skilled Draughtsmen and First Class Engineers, all branches; our special postal training will make you suitable.—Dept. 92, The Bennett College, Ltd., Sheffield. [0437]

19/6—B.T.H. Electric Motors, 1.50th.h.p., universal D.C. or A.C. 2,000 r.p.m., phenomenal bargain; cannot repeat, guaranteed new; add 2/- packing and C.O.D.; trade inquiries invited.—Easco, 18, Brixton Rd., London, S.W.9. [6451]

AMBITIOUS Men, you can qualify for a well paid post by studying at home with The T.I.G.B.; write to-day for "The Engineer's Guide to Success," 152 pages, free, which contains the widest selection of engineering and wireless courses in the world, and shows you how to become A.M.I.E.E., A.M.I.Mech.E., A.Rad.A., etc.; state branch, post or qualification that interests you.—The Technological Institute of Great Britain, 81, Temple Bar House, London, E.C.4. (Founded 1917, 19,000 successes.) [6481]

PATENT AND TRADE MARK AGENTS.
A. MATHISEN, Chartered Patent Agent; patents, designs and trade marks.—First Avenue House, High Holborn, London, W.C.1. Holborn 8950. [5284]

GEE and Co. (H. T. P. Gee), Patent Agent for Great Britain, U.S.A., Canada, etc., Mem. R.S.G.B., A.M.I.R.E.I., 51-52, Chancery Lane, London, W.C.2 (two doors from Government Patent Office). 'Phone: Holborn 1525. Handbook free. [0001]

TUITION.
THERE is Always a Demand for Qualified Radio Engineers; write for brochure describing Home Study Course.—National Institute of Radio Engineering, Guildhall St., Preston. [0438]